

FILED WASCO CTY
THE DALLES OR.

IN THE COUNTY COURT OF THE STATE OF OREGON

Oct 12 1 34 PM '00

IN AND FOR THE COUNTY OF WASCO

KAREN R. LEBRETTON
COUNTY CLERK

IN THE MATTER OF ADOPTING A)
SPECIFIC SERVICE SIGNING)
ORDINANCE FOR WASCO COUNTY,)
OREGON.)

ORDINANCE

THE COUNTY COURT OF WASCO COUNTY, OREGON DOES ORDAIN AS FOLLOWS:

SECTION I. AUTHORITY

The following procedures and requirements relating to the placing of Specific Service Signing within the right-of-way for public roads in Wasco County is authorized by ORS 368.942 to 368.950, and furthermore Section 2G-5 of the Manual on Uniform Traffic Control Devices, attached hereto as Exhibit "A" and by this reference made a part hereof, authorizes and defines how the signing shall be installed.

The Department of Public Works is also authorized to develop such forms and procedures as are necessary for the implementation of this Ordinance. Said forms are attached as Exhibits "B", "C", "D" and "E" and by this reference made a part hereof. Other forms may be developed and used as the need arises.

SECTION II. PURPOSE AND APPLICABILITY

The purpose of this Ordinance is to control the use of advertising signs on public roads within Wasco County while still providing the necessary directional information to allow drivers to locate visitor-oriented businesses. The Ordinance establishes standards for Specific Service Signing erected within County rights-of-way.

12000-0374 (26)

1 This Ordinance is applicable only to public roads outside of
2 incorporated city limits. Placement of signs on County roads within
3 incorporated city limits will be authorized only by regulations
4 jointly agreed to by the Wasco County Court and the appropriate City
5 Council.

6 SECTION III. DEFINITIONS

7 As used in these rules, the following definitions shall apply
8 unless the context indicates otherwise:

9 "Advanced Guide Sign" means Specific Service Signing
10 located in advance of a road intersection.

11 "Applicant" means a person applying for a permit for
12 Specific Service Signing. The Applicant shall be either
13 the "Owner" or the "Responsible Operator" as further
14 defined in this Ordinance.

15 "Specific Service Sign" means a sign with the name of a
16 visitor-oriented business, service, or activity, together
17 with directional information erected in advance of or at
18 intersections on the County road system.

19 "Directional Information" means the necessary information
20 to direct the motoring public.

21 "Engineer" means the Wasco County Director of Public Works
22 or designee thereof.

23 "Intersection Guide Sign" means Specific Service Signing
24 located where two or more County roads meet.

25 "Logo" means the portion of the sign with the
26 identification of the business or activity on it.

- 2000-0374 (26)

1
2
3
4
5
6
7
8
9
10
11
12
13
14
15
16
17
18
19
20
21
22
23
24
25
26
Page

"Owner" means a holder of fee title, or lessee.

"Visitor-Oriented Business" means any legal gas, food, lodging, or camping facility, recreational, educational or entertaining activity, or a unique or unusual commercial or nonprofit activity, a substantial portion of whose income or visitors are derived during its normal business season from motorists not residing in the immediate area of the activity.

"Responsible Operator" means a person or entity other than an owner who operates a visitor-oriented business and who has authority to enter into an agreement relative to matters covered by this Ordinance.

"Road Department" means the Wasco County Public Works Department.

SECTION IV. CRITERIA FOR ELIGIBILITY

1. A visitor-oriented business must be located within 8 miles of the intersection where the visitor-oriented directional signs are proposed to be installed. The distance will be measured as vehicle distance from the center point of the intersection to the nearest point of the intersection of the driveway of the business and a public highway.
2. Specific Service Signing shall not be used for any business if it is easily visible and identifiable from the traveled way the last 300 feet from the intersection or road approach to the business.

/////

02000-0374 (26)

1
2
3
4
5
6
7
8
9
10
11
12
13
14
15
16
17
18
19
20
21
22
23
24
25
26
Page

- 3. A visitor-oriented business shall have:
 - A. Continuous operation at least 6 hours per day, 5 days a week, during its normal business season.
 - B. Licensing where required.
 - C. Adequate parking accommodations.
- 4. If applications are received for any one intersection for more than the allowable number of signs, the order of priority shall be based on the date of receipt of a properly completed application.
- 5. Any grant of a new or renewed application shall entitle the Applicant to the continuance of its Specific Service Signing for as long as requirements of this Ordinance are met.
- 6. Notwithstanding the fact that a visitor-oriented business meets all of the other eligibility requirements of this Ordinance, an application may be denied if it is determined after investigation by the Engineer that adequate direction to the business cannot be given by a reasonable number of allowable Specific Service Signing.

SECTION V. SIGN CONSTRUCTION AND COMPOSITION

- 1. The Specific Service Signing, consisting of the sign panel with the logos and directional information, shall be furnished to the County by the Applicant(s).
- 2. Each logo:
 - A. Shall be 24" wide and 18" high.

//////

D2020-0374 (26)

1
2
3
4
5
6
7
8
9
10
11
12
13
14
15
16
17
18
19
20
21
22
23
24
25
26

- B. Shall have a content limited to the identification of the business and shall not include promotional advertising, as determined by the Engineer.
- C. Shall have no messages, symbols and trademarks which resemble any official traffic control device.
- 3. The directional information for each legend:
 - A. Shall be constructed of white reflectorized material.
 - B. Intersection Guide Signs shall have a direction arrow and the distance to the facility to the nearest one-quarter mile.
 - C. Advanced Guide Signs shall have directional word information "AHEAD" or "NEXT LEFT" or "NEXT RIGHT" as may be required instead of the direction arrow.
- 4. Each sign panel:
 - A. Shall conform to O.D.O.T. Low Speed/Low Volume Road Standards as depicted in Exhibits "F" and "G".
 - B. Shall have logos and directional information mounted on a blue reflectorized panel with a white reflectorized border.
- 5. No more than two panels shall be installed at any sign post location.
- 6. Design of the sign shall be approved by the Engineer before construction.

/////
/////
/////

02000 0374(26)

1
2
3
4
5
6
7
8
9
10
11
12
13
14
15
16
17
18
19
20
21
22
23
24
25
26
Page

- 7. The sign shall be constructed by a manufacturer approved by the Road Department to make the Specific Service Signing. The Engineer may reject any sign constructed with improper materials, design or workmanship.
- 8. The Road Department will furnish the posts and install all signs in the road right-of-way.

SECTION VI. SIGN LOCATION

- 1. Specific Service Signs are only for use in areas outside the incorporated city limits.
- 2. Specific Service Signing may be installed within Urban Growth Boundaries only with the written approval of the City involved.
- 3. Specific Service Signing should be located so as to take advantage of natural terrain, to have the least impact on the scenic environment, or with the view of residences and business on the adjacent property.
- 4. Specific Service Signing shall not be installed where there may be conflict with traffic control devices, or where any unsafe condition may be created as determined by the Engineer.
- 5. Advanced Guide Signs are to be located at least 300, but not more than 600, feet in advance of the intersection, wherever possible.

/////
/////
/////

Prora 0374 (26)

1
2
3
4
5
6
7
8
9
10
11
12
13
14
15
16
17
18
19
20
21
22
23
24
25
26
Page

- 6. The use of both an Advanced Guide Sign and an Intersection Guide Sign for the same business at the same intersection is not allowed. The use of an Intersection Guide Sign or an Advanced Guide Sign is at the discretion of the Engineer.
- 7. There shall be no more than four sign post locations per intersection direction (including both Intersection and Advanced Guide Signs).
- 8. The Engineer shall determine the location of all Specific Service Signing. This determination shall be based on a field investigation, the criteria of this Ordinance and traffic engineering principles.

SECTION VII. APPLICATION, FEES AND MAINTENANCE

- 1. Initial application and installation:
 - A. The Applicant must file an application for installation of its Specific Service Signing on a form specified by Wasco County. The application will include a copy of the proposed legend and sign design.
 - B. The first year annual fee must be submitted with the application.
 - C. The Engineer will determine the location of the Specific Service Signing and notify the Applicant of the location.
 - a) The Engineer's determination of the sign location is final and not subject to appeal.

////

2000 0374 (26)

1
2
3
4
5
6
7
8
9
10
11
12
13
14
15
16
17
18
19
20
21
22
23
24
25
26
Page

b) If the Engineer determines that no acceptable location exists for the Specific Service Signing, the entire annual fee will be refunded.

c) If the Applicant does not approve of the sign location, the Applicant may withdraw the application, in which case 50% of the annual fee will be refunded.

D. The Applicant shall have the sign constructed and delivered to the Road Department within 90 days of notification of the sign location. Failure to provide the sign within 90 days will be considered a withdrawal of the application.

E. The Road Department shall install the sign.

2. Fees and charges:

A. The annual fee for each Specific Service Signing shall be \$75 per business, per sign.

B. The anniversary date for the annual permit shall be January 1 of each year.

C. An additional fee of \$25 will be charged when temporary removal and reinstallation of signs is required due to seasonal nature of business or activity or for failure to submit a renewal application on time.

3. Sign Maintenance:

A. All field maintenance of the Specific Service Signing will be done only by Road Department personnel.

/////

02000 0374 (24)

1
2
3
4
5
6
7
8
9
10
11
12
13
14
15
16
17
18
19
20
21
22
23
24
25
26
Page

B. In the case of missing sign:

- a) The Engineer will notify the Applicant(s) the sign is missing.
- b) When the Applicant(s) supply the Road Department with a new sign, the Road Department will install the new sign at no additional expense to the Applicant.
- c) If the Applicant(s) do not supply a new sign, there will be no refund of the annual fee.

C. In the case of a damaged sign:

- a) The Road Department will remove the sign and store it in the nearest Road Department Shop.
- b) The Engineer will notify the Applicant(s) the sign is damaged and where it is located.
- c) When the Applicant(s) supply the Road Department with a new sign, the Road Department will install the new sign at no additional expense to the Applicant(s).
- d) If the Applicant(s) do not supply a new sign, there will be no refund of the annual fee.

D. In the case of a sign which has deteriorated due to normal weathering:

- a) The Engineer shall make a determination that the sign needs upgrading and notify the Applicant(s).

////

////

2000-0374 (76)

1
2
3
4
5
6
7
8
9
10
11
12
13
14
15
16
17
18
19
20
21
22
23
24
25
26

- b) The Applicant(s) shall provide the Road Department with a new sign before the next anniversary date, or within 90 days, whichever is later.
- c) The Road Department will install the new sign at no additional expense to the Applicant(s).
- d) If the Applicant(s) fail to provide a sign the permit will be revoked and the sign removed.

SECTION VIII. SIGN PERMIT TERMINATION

- 1. The sign permit may be revoked and the sign removed for any of the following reasons:
 - A. If the visitor-oriented business fails on a sufficient number of occasions or over a sufficient period of time to provide all of the services, so as to justify a finding by the Engineer that the business is not in substantial compliance with this Ordinance.
 - B. If the visitor-oriented business fails during its normal business season to open for business for more than 7 consecutive days or for more than 10 cumulatively, during any one month period, unless the Engineer finds that closure for such period was beyond the control of the owner or responsible operator, or that the closure was justified by extenuating circumstances.
 - C. Failure to notify the Engineer of seasonal closures, along with the temporary removal fee.
 - D. Failure to pay renewal fees.

02000-0374(26)

1
2
3
4
5
6
7
8
9
10
11
12
13
14
15
16
17
18
19
20
21
22
23
24
25
26
Page

E. Failure of the Applicant to provide the Road Department with a new sign when notified of the need by the Engineer.

F. If Wasco County Road Department elects to discontinue the program, in which case prorated sign fees paid within the current year will be refunded.

2. If due to fire, accident or similar cause, a visitor-oriented business becomes inoperable for an extended period of time, exceeding 7 days but not more than 90 days, its Specific Service Signing shall be temporarily removed, but the business shall not lose its priority, nor be required to reapply prior to the normal time for a renewal application. Further, extension may be granted on good cause shown. However, failure of the owner or responsible operator to proceed with necessary repairs as rapidly as possible shall cause loss of the right to continued placement of the Specific Service Signing and require a new application.

SECTION IX. ILLEGAL SIGNS

1. No business or advertising signs shall be allowed on public road right-of-ways, outside of incorporated city limits, except as permitted by this Ordinance.

2. Signs in existence on October 11, 2000 are not in violation of this Ordinance until October 11, 2003.

/////

/////

02000-0374 (26)

1
2
3
4
5
6
7
8
9
10
11
12
13
14
15
16
17
18
19
20
21
22
23
24
25
26
Page

3. The replacement of existing signs in public road right-of-ways after the adoption of this Ordinance is a violation of this Ordinance.

4. 30 days after the installation of a new Specific Service Signing, all other signs by that business within any public road right-of-way become a violation of the Ordinance.

SECTION X. SAVINGS CLAUSE

If any section or part thereof of this Ordinance shall be held illegal, unconstitutional, or void, this shall not be construed to render void any other provision or requirement of this Ordinance.

SECTION XI. ENFORCEMENT

This Ordinance may be enforced in any manner authorized by state or local law, including ORS Chapters 368 and 374.

SECTION XII. ADOPTION

Since many of the advertising and business signs now in existence on public roads within Wasco County have existed for over a decade, it does not seem necessary to declare that their removal requires the immediate adoption of this Ordinance for the preservation of the public peace, health and safety. Therefore an emergency is not declared to exist and this Ordinance shall take effect 90 days after its adoption.

DATE OF FIRST HEARING: September 13, 2000

DATE OF SECOND HEARING: October 11, 2000

/////
/////
/////

D2000-0374 (26)

1
2
3
4
5
6
7
8
9
10
11
12
13
14
15
16
17
18
19
20
21
22
23
24
25
26

Regularly passed and adopted by a unanimous vote of all members
of the County Court of the County of Wasco, State of Oregon, this
11th day of October, 2000.

WASCO COUNTY COURT

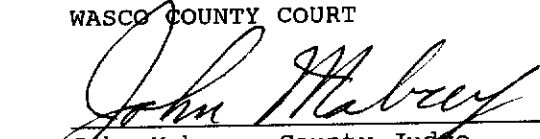
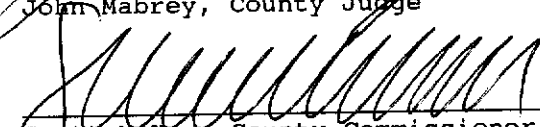
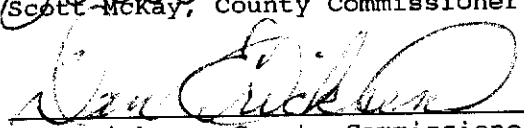
John Mabrey, County Judge

Scott McKay, County Commissioner

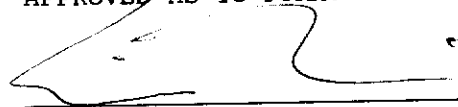
Dan Ericksen, County Commissioner

APPROVED AS TO FORM:

Eric J. Nisley
Wasco County District Attorney

ATTEST:

Karen LeBreton
Wasco County Clerk

02000-0374 (26)

2G-5 SPECIFIC SERVICE SIGNINGII-1 (c)
Rev. 4**2G-5.1 Application of Specific Service Signs**

Specific service signs provide travelers with business identification and directional information for essential motorist services. The signs may be used on any class of highway and are intended for use primarily on areas rural in character. The use of specific service signs should be based on a determination of motorist need for this type of signing.

Specific service signs, if used, shall carry word legends for one (or two in remote rural areas, see Section 2G-5.5) of the following services, GAS, FOOD, LODGING, OR CAMPING, along with an appropriate directional legend such as NEXT RIGHT, SECOND RIGHT or directional arrows, the exit number where applicable, and one or more separately attached business logos. The signs shall have white reflectorized uppercase letters, numbers, arrows, and borders on a blue background. The signs may be illuminated. Typical specific service signs are shown in Figure 2-47. The color and size of logos on a sign are specified in Sections 2G-5.2 and 2G-5.3.

II-161 (c)
Rev. 5II-161 (c)
Rev. 5

The number of signs shall be limited to one for each type of service along an approach to an interchange or intersection. The number of logos permitted on a sign is specified in Sections 2G-5.5 and 2G-5.6.

In the direction of traffic, successive specific service signs shall be those of CAMPING, LODGING, FOOD, and GAS in that order. The signs should be located so as to take advantage of natural terrain, to have the least impact on the scenic environment, and to avoid visual conflict with other signs within the highway right-of-way. Unprotected sign supports located within the clear zone shall be of a breakaway type of design. Typical sign locations are shown in Figure 2-48.

2G-5.2 LOGOS

A business logo, which may consist of the business identification symbol, name, brand, trademark, or combination, shall be shown on a separate panel which is attached to the specific service sign. Logos should have a blue background with a white legend and border. The principle legend should be at least equal in height to the directional legend on the sign. Where business identification symbols or trademarks are used alone for a logo, the border may be omitted, the symbol or trademark shall be reproduced in the colors and general shape consistent with customary use, and any integral legend shall be in proportionate size.

II-161 (c)
Rev. 5

Messages, symbols, and trademarks which resemble any official traffic control device shall not be used.

2G-5.3 Size of Logos and Signs

Each logo, including its border, when attached to a specific service sign, shall be contained within a rectangular background area which shall not exceed the dimensions shown in Table II-4 for the applicable class of highway and location. Category 1 sizes are for use on expressways where access to crossroads is provided by at-grade intersections. Category 2 sizes are intended as alternates for signing at-grade intersections located between interchanges on expressways. Category 2 sizes shall be used only in conformance with the State signing policy specified in Section 2G-5.8.

Table II-4 Logo Sizes

Class of Highway	GAS		FOOD LODGING CAMPING	
	Width	Height	Width	Height
Freeway (Section 2F-1)	48"	36"	60"	36"
Expressways (Section 2E-1)				
Interchanges	48"	36"	60"	36"
Intersections—Category 1 . . .	36"	24"	36"	24"
Intersections—Category 2 . . .	48"	36"	60"	36"
Conventional Roads and Ramps	24"	18"	24"	18"

II-161 (c)
Rev. 5

Sign sizes must be fixed primarily in terms of the amount and height of legend and the number and size of logos attached to the sign. The vertical and horizontal spacing between logos shall not exceed 8 inches and 12 inches, respectively. Reference shall be made to Sections 2A-19, 2E-12, and 2F-12 for information on borders and on interline and edge spacing.

2G-5.4 Size of Lettering

All letters and numerals on specific service signs, other than on the logos, shall conform to the sizes specified in Table II-5. Letter sizes specified for Expressway Intersections, Category 2, shall be used only in

Table II-5—Letter and Numeral Sizes for Specific Service Signs

	Freeways	Expressways		Ramps and Conventional Highways	
		Interchanges	Intersections		
			Category 1		Category 2
Services	10"	10"	6"	10"	4"
Action Message	10"	10"	6"	10"	4"
Exit Legends					
Words	10"	10"			
Numeral	10"	10"			
Letter	10"	10"			

02000-0374 (20)

conjunction with Category 2 logo sizes given in Table II-4. Arrow details are provided in the publication "Standard Highway Signs." *

2G-5.5 Signing at Interchanges

When used on freeways or at interchanges on expressways, a separate specific service sign shall be used for each type of service for which logos are displayed. Exceptions may be made at remote rural intersections. The specific service signs shall be erected between the previous interchange and 800 feet in advance of the exit direction sign at the interchange from which the services are available. There should be at least 800 feet spacing between the signs. Excessive spacing is not desirable. Specific service signs should not be erected at an interchange where the motorist cannot conveniently reenter the freeway or expressway and continue in the same direction of travel.

At single-exit interchanges, the name of the type of service followed by the exit number shall be displayed on one line above the logos. At unnumbered interchanges, the directional legend NEXT RIGHT (LEFT) shall be substituted for the exit number. The GAS specific service signs should be limited to six logos and the FOOD, LODGING, and CAMPING specific service signs should be limited to four logos each.

II-161 (Rev. 5)

At double-exit interchanges, the specific service signs should consist of two sections, one for each exit. The top section shall display the logos for the first exit and the lower section shall display the logos for the second exit. The name of the type of service followed by the exit number shall be displayed in a line above the logos in each section. At unnumbered interchanges, the legends NEXT RIGHT (LEFT) and SECOND RIGHT (LEFT) shall be substituted for the exit numbers. Where a type of motorist service is to be signed for at only one exit, one section of the specific service sign may be omitted, or a single-exit interchange sign may be used. The number of logos on the sign (total of both sections) should be limited to six for GAS and four each for FOOD, LODGING, and CAMPING.

II-161 (Rev. 5)

In remote rural areas, where not more than two qualified facilities are available for each of two or more types of services, logos for two types of services may be displayed on the same sign. Not more than two logos for each type of service shall be displayed in combination on a sign. The name of each type of service shall be displayed above its respective logo(s), and the exit number shall be displayed above the names of the types of services. At unnumbered interchanges, the legend NEXT RIGHT (LEFT) shall be substituted for the exit number. Logos should not be combined on a sign when it is anticipated that additional service will become available in the near future. When it becomes necessary to display a third logo for a type of service displayed in combination, the logos involved shall then be displayed as required at single- or double-exit interchanges.

* Available from the Superintendent of Documents, U.S. Government Printing Office, Washington, D.C. 20402.

At single-exit interchanges, exit ramp signs shall be installed along the ramp or at the ramp terminal for service facilities which have business logos displayed along the main roadway except that logos for facilities visible from the ramp terminal may be omitted. Logos on ramp signs shall be duplicates of the corresponding logos installed along the main roadway, but reduced in size. The reduced size logos may also be installed along the crossroad. Ramp signs should include distances to the service facilities. Directions shall be indicated by arrows. The minimum letter height should conform to Table II-5, except that any legend on a symbol shall be proportional to the size of the symbol. Ramp signing may be used on ramps and crossroads at double-exit interchanges.

II-161 (c)
Rev. 5

2G-5.6 Signing at Intersections

When specific service signs are used on conventional roads and at intersections on expressways, they should be erected between the previous interchange or intersection and 300 feet in advance of the intersection from which the services are available. The spacing between signs should be determined on the basis of an engineering study. Signs similar to exit ramp signs may be provided on the crossroad. Logos should not be displayed for a type of service for which a qualified facility is visible from a point on the traveled way 300 feet from the intersection.

Each specific service sign should be limited to four logos. Not more than four logos for each type of service should be displayed along each approach to the intersection. A maximum of two logos for each of two different types of services may be combined on the same sign. The name of each type of service shall be displayed above its logo(s), together with an appropriate legend such as NEXT RIGHT (LEFT) or a directional arrow.

II-161 (c)
Rev. 5

2G-5.7 Guidelines for Specific Service Signing

Use of specific service signing should conform to the following guidelines:

1. Eligible service facilities shall comply with laws concerning the provisions of public accommodations without regard to race, religion, color, age, sex, or national origin, and laws concerning the licensing and approval of service facilities.

2. Distances to eligible services should not exceed 3 miles in either direction, except that, if within the 3 miles limit, services of the type being considered are not available, the limit of eligibility may be extended in 3 mile increments until one or more services of the type being considered, or 15 miles, whichever comes first, are reached.

3. The use of GAS signs including:

- (1) vehicle services including fuel, oil, tire repair, and water;
- (2) restroom facilities and drinking water;

(3) continuous operation at least 16 hours per day, 7 days per week, for freeways and expressways, and continuous operation at least 12 hours per day, 7 days per week, for conventional roads; and

(4) telephone.

4. The use of FOOD signs including continuous operations to serve three meals a day, 7 days a week and a telephone.

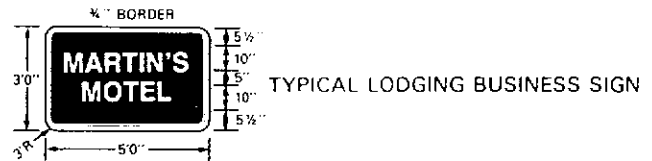
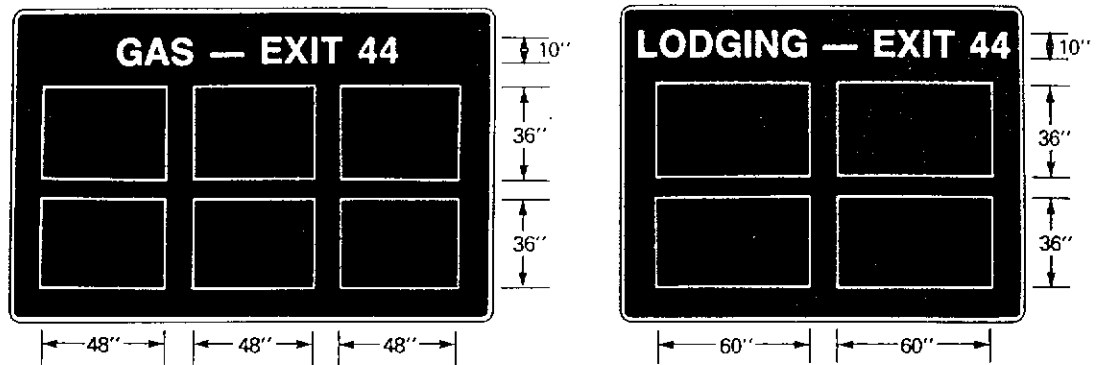

SINGLE EXIT INTERCHANGE

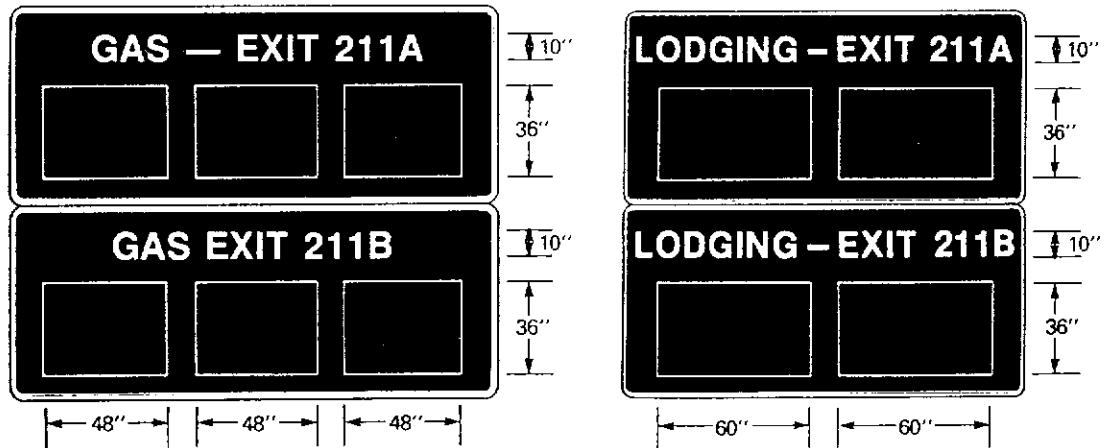

DOUBLE EXIT INTERCHANGE

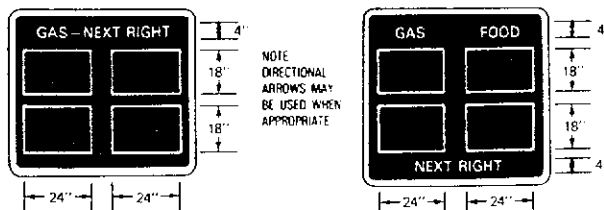

INTERSECTION

Figure 2-47. Typical Specific Service Signs

P2000-0374
Low

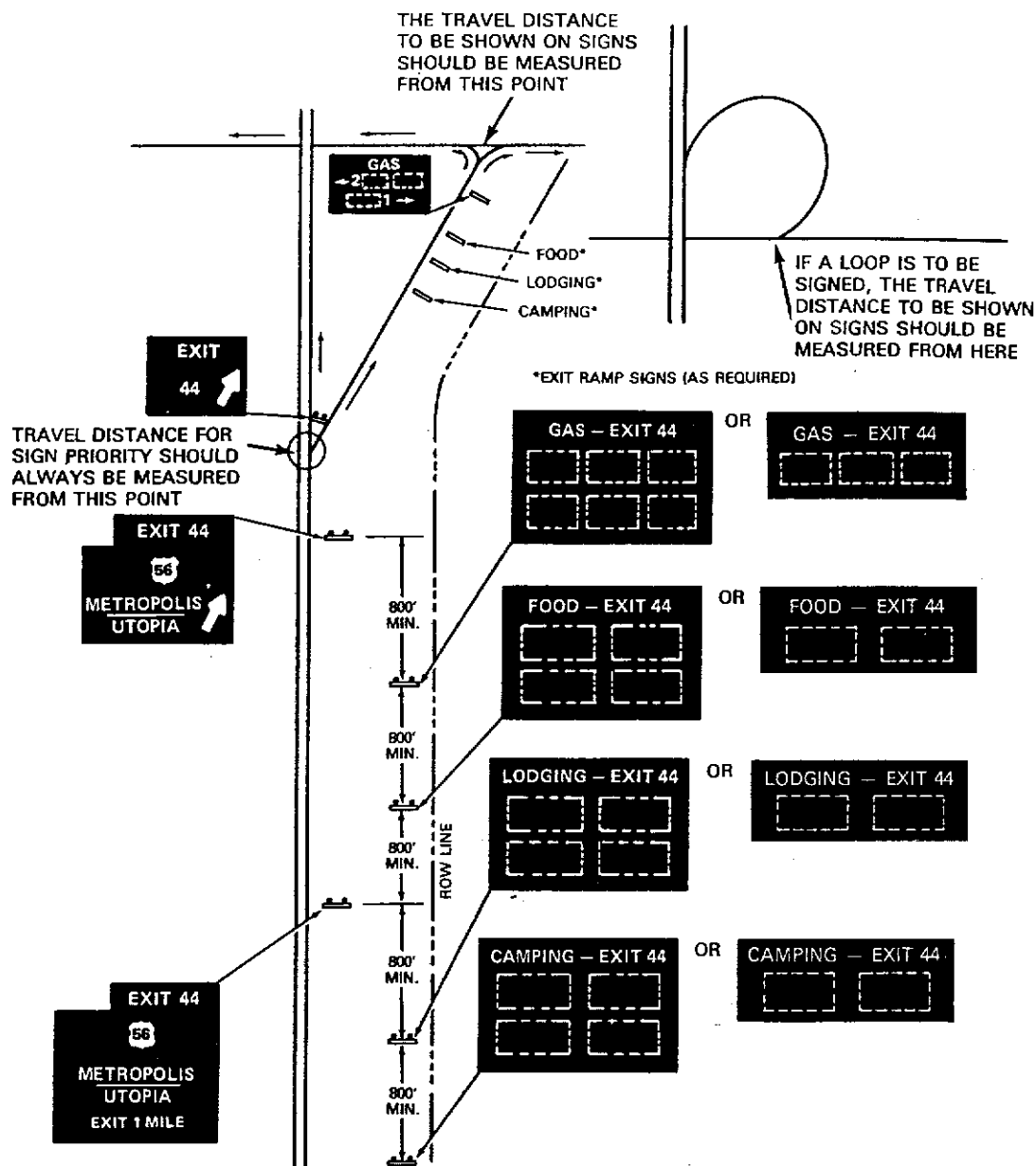

Figure 2-48. Typical Signing for Interchanges

5. The use of LODGING signs including adequate sleeping accommodations, and a telephone.

6. The use of CAMPING signs including adequate parking accommodations, modern sanitary facilities, and drinking water.

2G-5.8 Signing Policy

Each agency with highway jurisdiction that elects to use specific service signs should establish a signing policy which includes, as a minimum, the Provisions of Section 2G-5.7 and the following criteria:

1. Selection of eligible businesses.
2. Distances to eligible services.

D2000-0-0374 (26)

3. The use of logos and legends conforming to the requirements of Tables II-4 and II-5.

4. Removal or covering of logos during off seasons for business operating on a seasonal basis.

5. The circumstances, if any, in which specific service signs may be used outside rural areas.

6. Determination of the costs to businesses for initial permits, installations, annual maintenance, removal, etc., of logos.

A2000-0374 (26)

EXHIBIT "B"

DATE:

TO:

FROM: WASCO COUNTY PUBLIC WORKS
2705 E. Second
The Dalles, Oregon 97058

RE: SPECIFIC SERVICE SIGN PERMIT # _____

LOCATION(S): _____

Enclosed is your approved permit for Business Guide Sign Placement. Please review the permit. **ALL RENEWAL FEES ARE DUE AND PAYABLE ON JANUARY 1ST OF EACH YEAR.**

Please let us know if you have any comments or suggestions regarding the Specific Service Signing Program.

Enclosure

P2000-00374'26)

WASCO COUNTY ROAD RIGHT-OF-WAY
SPECIFIC SERVICE SIGNING PLACEMENT PERMIT/APPLICATION
(One sign request per blank permit. Make additional copies as necessary.)

EXHIBIT "C"

PERMIT NO: _____ ROAD NAME: _____ ROAD NO: _____

Applicant must be the owner or person having legal right to represent the firm or business applying for the Specific Service Signing Placement Permit.

BUSINESS NAME: _____

MAILING ADDRESS: _____

CITY: _____ **STATE:** _____ **ZIP:** _____

STREET ADDRESS/LOCATION OF BUSINESS: _____

TAX DESCRIPTION:
TOWNSHIP _____ **RANGE** _____ **EAST, W.M. SECTION** _____ **TAX LOT** _____

Briefly describe the nature of your business or company: _____

BUSINESS METHOD OF OPERATION:
SEASONAL OPERATION: Y / N (circle) From _____ To _____
YEAR-AROUND OPERATION: Y / N (circle)

ADDRESS & ROAD FOR REQUESTED SIGN LOCATION _____

NEAREST INTERSECTING ROAD _____

DISTANCE & DIRECTION FROM INTERSECTING ROAD _____

PROPOSED SIGN SKETCH ATTACHED: Y / N (circle)

SIGN VISIBLE FROM: North _____ South _____ East _____ West _____

This application is made pursuant to Wasco County Specific Service Signing Ordinance and O.R.S. Chapter #368. The applicant agrees to save and hold harmless the County for any and all liability of whatever kind or nature arising or to arise by reason of issuance of this Specific Service Signing Permit. Applicant is to have the sign constructed to County standards and delivered to the Road Department within 90 days of notification of the sign location. Failure to provide the sign within the 90 days will be considered a withdrawal of the application.

All field maintenance to be performed by Road Department personnel only. Adjustments or maintenance not permitted by applicant.

All expense of replacement due to damage, vandalism, or deterioration shall be borne by the applicant. Road Department will install new sign supplied by applicant at no additional cost if provided under Ordinance guidelines.

APPLICANT'S SIGNATURE AND DATE **TITLE**

FORM TO BE RETURNED TO: WASCO COUNTY PUBLIC WORKS
2705 E. Second Street
The Dalles, Oregon 97058

FEEES MUST BE SUBMITTED WITH APPLICATION: \$75.00 per sign application. All checks are to be made payable to "Wasco County Public Works".

P2000-0374 (26)

EXHIBIT "D"

THIS PORTION OF APPLICATION FOR DEPARTMENT USE ONLY

DATE APPLICATION RECEIVED: _____ FEE PAID: \$ _____

BUSINESS LOCATED ON: _____ MILE POST: _____

CLOSEST INTERSECTION: _____

APPROXIMATE MILEAGE FROM INTERSECTION TO BUSINESS: _____

APPROVED FOR

INTERSECTION GUIDE SIGN / ADVANCED GUIDE SIGN (circle type)

DATE APPROVED: _____

LOCATION/ROAD: _____ MILE POST: _____

APPROVED SKETCH DETAILS: _____

LOGO/SIGN PREVIEW

DATE RECEIVED: _____

DATE APPROVED: _____

SIGN RECEIPT/PLACEMENT

DATE SIGN TO BE PROVIDED TO ROAD DEPARTMENT
(NLT 90 DAYS AFTER PERMIT APPROVAL): _____

DATE SIGN RECEIVED BY ROAD DEPARTMENT: _____

DATE SIGN POSTED BY MAINTENANCE: _____

APPLICATION DENIAL

REASON FOR DENIAL OF APPLICATION: _____

REFUND TO BE PROVIDED TO APPLICATION: \$ _____

DATE OF DENIAL LETTER TO APPLICANT: _____

P2006-0374 (26)

SPECIFIC SERVICE SIGN PERMIT SKETCH(ES)

Date: _____

LOCATION:

BS #:

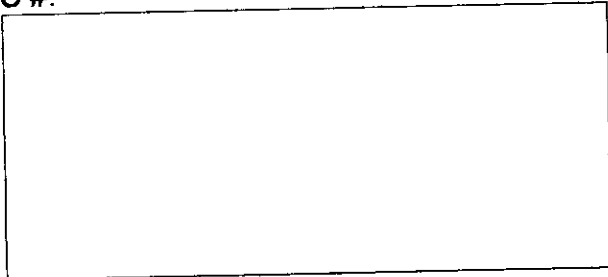

BS #:

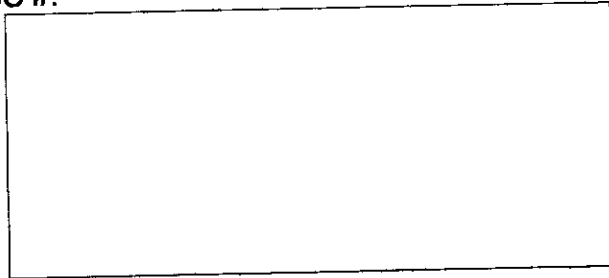

BS #:

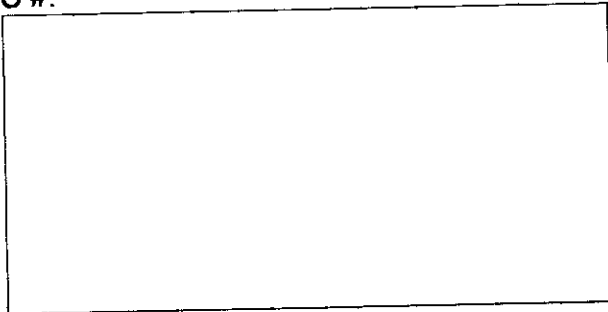

BS #:

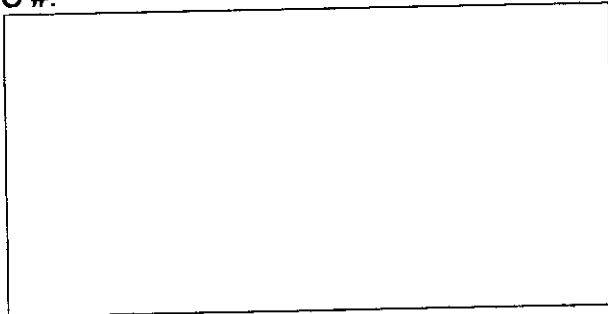

P2000-0374 (26)

ADVANCE OFF-INTERSTATE (LOW SPEED/LOW VOLUME)

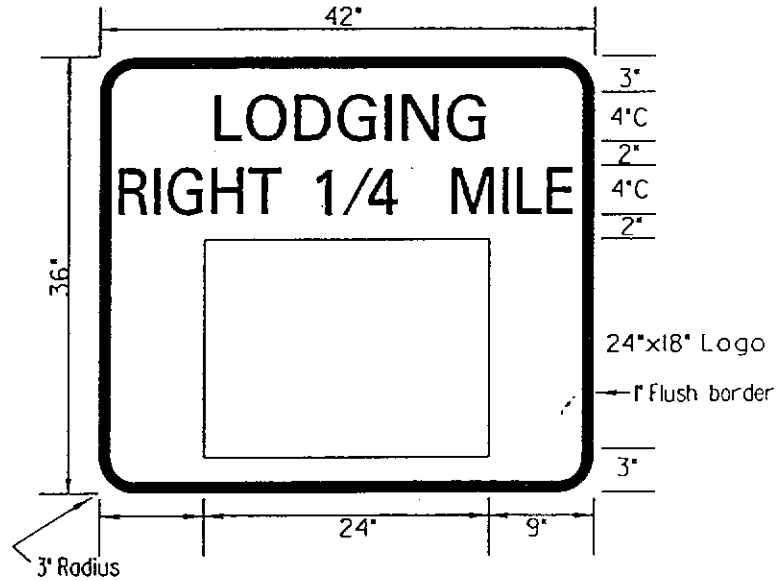

Fractions are linear

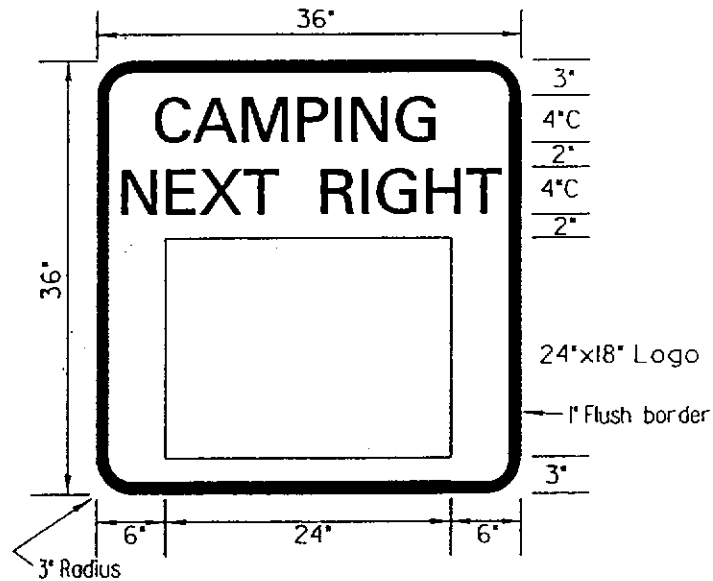

Sign Background: Blue, Reflective Sheeting
Sign Legend; White, Reflective

SIGNSTD.PG.F.13

127000-0374 (26)

OREGON DEPARTMENT OF TRANSPORTATION

Approved By: S.T.E.

Date: 3/94

Publication Date: 3/98

OFF-INTERSTATE INTERSECTION LOW SPEED/LOW VOLUME

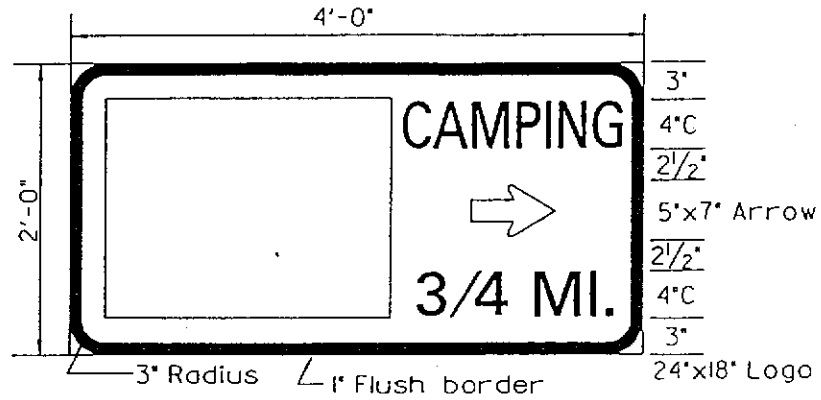

OFF-INTERSTATE COMBINATION ADVANCE LOW SPEED/LOW VOLUME

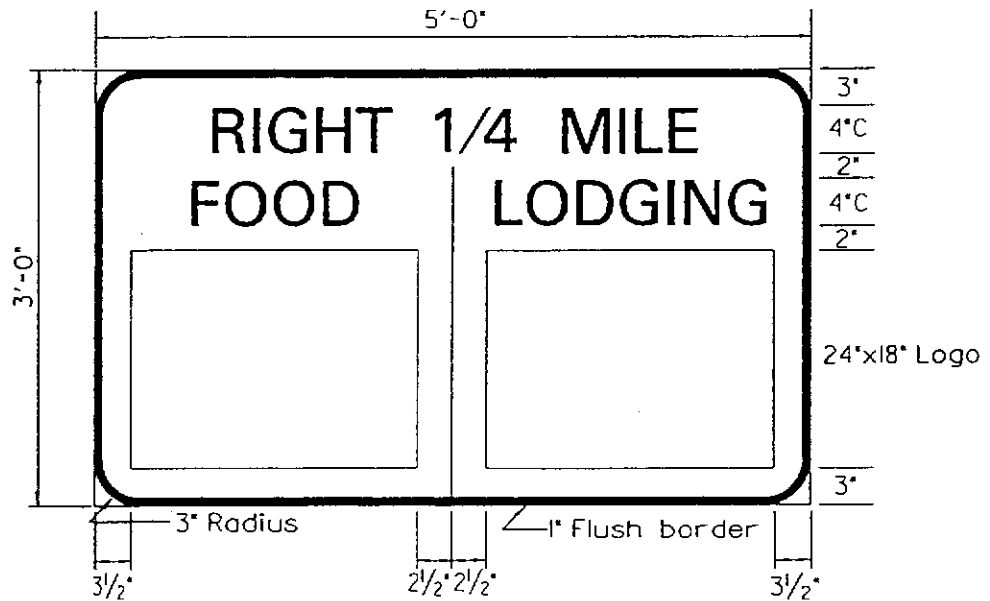

SIGNSTD.PG.F.13

12000-0374 (26)

Vert. spacer bar is 1/2" wide

OREGON DEPARTMENT OF TRANSPORTATION

Approved By: O.T.C.

Date: 1/92

Publication Date: 3/98