



**NOTICE OF REGULAR MEETING
SEALY CITY COUNCIL
CITY COUNCIL CHAMBERS
415 MAIN STREET
SEALY, TX 77474
TUESDAY, MARCH 3, 2026
6:00 P.M.**

Notice is hereby given of a Regular Meeting of the City Council of Sealy to be held on the abovementioned date, time, and location for the purpose of considering the following agenda items. All agenda items are subject to action. The City Council reserves the right to meet in a closed session on any agenda item should the need arise and if applicable pursuant to authorization by Title 5, Chapter 551, of the Texas Government Code.

A. Call to Order

B. Invocation and Pledges of Allegiance

C. Roll Call and Certification of a Quorum

D. Petition(s) and Public Comments

Comments may not be addressed to or at individuals and are limited to three minutes per speaker; however, if a large quantity of individuals has registered to speak, the time may be reduced. Speakers may not poll the council members or attendees.

E. Discussion and Possible Action to Approve the agenda order or reorder

F. Proclamation(s)

- **35th Anniversary of Reverend Charles Boyd Frazier**

G. Consent Agenda

(In accordance with Sec. 2-35. (1) of the Code of Ordinances, "Routine matters thought to require little or no deliberation by city council may be placed on a consent agenda, which shall be treated as one agenda item." At any time prior to the call for a vote on the consent agenda, any council member may request that one or more items may be removed from the consent agenda and handled separately in the same manner as a regular agenda item.)

a) Approve the February 18, 2026, Regular Meeting Minutes

b) Approve Amending Calling and Ordering a General Election to be held on May 2, 2026

c) Approve Memorandum of Understanding regarding the eTrace Internet Based Firearm Tracing Application

d) Approve a Resolution for Public Works Salvage Property of Pool Furniture

e) Approve a Flock Camera Contract, adding to City Property

H. Public Hearing: The City Council for the City of Sealy, Texas, will hold a Public Hearing on Amending the Fiscal Year 2025-2026 Budget of the City of Sealy, Texas, to be held on the 3rd day of March, at 6:00 p.m. in the City Council Chamber located at 415 Main Street, Sealy, Texas 77474. All interested persons shall be given an opportunity to be heard for or against any item or the amount of any item contained in the Proposed Budget Amendment.

I. Business

1. Discussion and Possible Action regarding an Ordinance for Amending the Fiscal Year 2025-2026 Budget.
2. Discussion and Possible Action regarding the Review of the Existing Contract for Voice Over Internet Protocol (VOIP) Services, including Possible Termination, Selection of a Contractor, and Approval of a Contract.
3. Discussion and Possible Action regarding Approving an Interlocal Agreement between the City of Sealy and Emergency Service District #2.
4. Discussion and Possible Action regarding Texas Historical Commission Designation Review and Authorization to Bid for Liedertafel Hall Project.
5. Discussion and Possible Action regarding Review and Consideration of Amendments to Ordinance Chapter 42 – Food Trucks.
6. Discussion and Possible Action regarding Creation of an Ordinance for Electric Bicycles, Electric Scooters, Electric Skateboards, Electric Riding toys, Mopeds, Motor-Assisted Scooters, Pocket Bikes, Minimotorbike, and Motor-Assisted Mobility Devices.
7. Reports or Requests from the City Manager and Discussion:
8. Reports, Announcements, or Requests from Councilmembers.

J. Adjourn

CERTIFICATION

I, Sandra Vrablec, City Secretary of the City of Sealy, do hereby certify that the above notice of the City of Sealy, Texas, City Council, was posted in a place convenient to the general public (and the City's website) in compliance with Chapter 551, of the Texas Government Code, and at least 3 business days before the scheduled time of the meeting.



Sandra Vrablec, City Secretary

F. PROCLAMATION(S)

City of Sealy, Texas



Proclamation - 35th Anniversary of Reverend Charles Boyd Frazier

WHEREAS, 35 years ago, on March 20, the Reverend Charles Boyd Frazier became pastor of the Bethel Baptist Church in Sealy; and

WHEREAS, Reverend Frazier has given generously of his time and life to minister to the spiritual needs of his congregation; and

WHEREAS, Reverend Frazier's steadfast dedication and commitment have endeared him to the many lives he has touched.

NOW, THEREFORE, I, Carolyn Bilski, on behalf of the City Council of the City of Sealy, encourage all citizens to join with the congregation of Bethel Baptist Church in thanking Reverend Frazier for his selfless service to God, the church, and the community, and wishing him continued years of health and service.

Witness my hand and the official seal of the City of Sealy, this 3rd day of March 2026.

Carolyn Bilski, Mayor

G. CONSENT AGENDA

a)



**MINUTES
SEALY CITY COUNCIL
CITY COUNCIL CHAMBERS
415 MAIN STREET
SEALY, TX 77474
WEDNESDAY, FEBRUARY 18, 2026
6:00 P.M.**

The City Council of the City of Sealy, Texas, conducted the meeting scheduled for February 18, 2026, at 6:00 p.m., at the Sealy City Council Chambers located at 415 Main Street, Sealy, Texas, 77474.

A. Call to Order

Mayor Bilski called the meeting to order at 6:00 p.m.

B. Invocation and Pledges of Allegiance

Councilwoman Curry gave the Invocation, and Mayor Bilski led the Pledge of Allegiance

C. Roll Call and Certification of a Quorum

Present:

Carolyn Bilski	Mayor
Dee Anne Lerma	Councilmember, Place 1 Mayor Pro Tem
Chris Noack	Councilmember, Place 2
Bradley Miller	Councilmember, Place 3
Theadra Curry	Councilmember, Place 4
Edward Zapalac	Councilmember, Place 5

Absent:

Adam Burttschell	Councilmember, Place 6
------------------	------------------------

A quorum was declared present.

Staff Attending:

Kimbra Hill, City Manager
Sandra Vrablec, City Secretary
Tim Kirwin, City Attorney
Russell Grimes, Chief of Police
Scott Riske, Police Captain
Patrick Parsons, Public Works Director
Mike Barrow, Assistant City Manager/Planner
Bill Atkinson, EDC Director
Katherine Ellis, EDC Secretary
Charlie Wade, Tourism Manager

D. Petitions(s) and Public Comments

Clayton Harris, TxDOT, spoke on Agenda Item #1
Mark Curtin, TxDOT, spoke on Agenda Item #1
Mayor Carolyn Bilski, read a text message she received Praising Nick Hagen

E. Discussion and Possible Action to Approve the agenda order or reorder.

A motion was made by Councilwoman Curry to Approve the agenda order.
Councilwoman Lerma seconded the motion. Mayor Bilski called for the vote.

AYES: Bilski, Lerma, Noack, Miller, Curry, Zapalac

NOES: None

The motion carried.

F. Consent Agenda

(In accordance with Sec. 2-35. (1) of the Code of Ordinances, "Routine matters thought to require little or no deliberation by city council may be placed on a consent agenda, which shall be treated as one agenda item." At any time prior to the call for a vote on the consent agenda, any council member may request that one or more items may be removed from the consent agenda and handled separately in the same manner as a regular agenda item.)

- a) Amend January 21, 2026, Regular Minutes for formatting
- b) Approve February 3, 2026, Regular Minutes
- c) Approve Financial Report for Month Ending December 2025
- d) Approve Quarter 1 Investment Report for Fiscal Year 2025-2026
- e) Approve a Resolution to Appoint a New Alternate Judge and Approve a Professional Service Agreement for same
- f) Approval of a Sealy Economic Development Corporation Performance agreement for a Sign Project located at approximately 419 Meyer Street, with Funding from a Historic District and Business Improvement Grant in an amount not to exceed \$3,000
- g) Approve a Resolution Amending the Sealy Economic Development Corporation Bylaws
- h) Approval of a Contract for Voice Over Internet Protocol (VOIP) Services with RingCentral, Inc.

A motion was made by Councilman Zapalac to Approve the Consent Agenda, removing and tabling item "h" and approving all other items.

Councilman Miller seconded the motion. Mayor Bilski called for the vote.

AYES: Bilski, Lerma, Noack, Miller, Curry, Zapalac

NOES: None

The motion carried.

G. Business

1. Presentation, Discussion, and Possible Action regarding Approving a Resolution of Support for TxDOT to make improvements to the Intersections along Highway 36 at North Circle Drive, South Circle Drive, and Gebhardt Road in Sealy, Texas.

A motion was made by Councilwoman Lerma to Approve the Resolution.
Councilwoman Curry seconded the motion. Mayor Bilski called for the vote.

AYES: Bilski, Lerma, Noack, Miller, Curry, Zapalac
NOES: None

The motion carried.

2. Presentation, Discussion, and Possible Action regarding Accepting the Convention and Visitors Bureau Tourism Manager's Project and Financial Operations Status for Fiscal Year 2024-2025 Quarter 4 (July, August, and September).

A motion was made by Councilman Miller to so moved.
Councilwoman Lerma seconded the motion. Mayor Bilski called for the vote.

AYES: Bilski, Lerma, Noack, Miller, Curry, Zapalac
NOES: None

The motion carried.

3. Discussion and Possible Action regarding Approving an Interlocal Agreement between the City of Sealy and Emergency Service District #2.

A motion was made by Councilman Miller to table this agenda item.
Councilwoman Lerma seconded the motion. Mayor Bilski called for the vote.

AYES: Bilski, Lerma, Noack, Miller, Curry, Zapalac
NOES: None

The motion carried.

4. Discussion and Possible Action regarding Awarding or Rejecting Bid(s) for the 7th Street Waterline and Road Project.

A motion was made by Councilman Zapalac to Approve Awarding a 7th Street Waterline and Road Project to Sovrex, LLC at \$1,011,695.50 and Award the Contract for the same.
Councilwoman Curry seconded the motion. Mayor Bilski called for the vote.

AYES: Bilski, Lerma, Noack, Miller, Curry, Zapalac
NOES: None

The motion carried.

5. Discussion and Possible Action regarding Repaving of the Alley between Main Street and 4th Street running behind the Sealy Professional Building to the west of the alley and behind the Austin County State Bank to the east of the alley in an amount not to exceed \$50,000.

A motion was made by Councilwoman Lerma to Approve.
Councilman Miller seconded the motion. Mayor Bilski called for the vote.

AYES: Bilski, Lerma, Noack, Miller, Curry, Zapalac
NOES: None

The motion carried.

6. Discussion and Possible Action regarding Approval of Utility Application Programming Interface Agreement and Amendment One with API Integration and the City of Sealy Police Department.

A motion was made by Councilwoman Lerma to Approve Utility Application Programming Interface Agreement and Amendment One with API Integration and the City of Sealy Police Department.
Councilman Miller seconded the motion. Mayor Bilski called for the vote.

AYES: Bilski, Lerma, Noack, Miller, Curry, Zapalac
NOES: None

The motion carried.

7. Presentation and Discussion by the Public Workers Director:

- **Parks and Facilities Community Survey**
- **Splash Pad Opening Date**
- **Police Department Humidity and Facility Repairs Status**
- **Westview Terrace Storm Sewer Project**

Patrick Parsons, Public Works Director, stated the Parks and Facilities Community Survey runs through March 16th; Splash Pad Opening Date is March 6th but that could change; Police Department Humidity and Facility Repairs Status is that AMS came out and took a look; Westview Terrace Storm Sewer Project the substantial completion of the construction is April 11, 2026 if we have perfect weather days.

8. Reports or Requests from the City Manager and Discussion:

Kimbra Hill, City Manager, updated on Strategic Planning, our Development Workflow, Annexation Considerations, and enhancing the quality of life with the upcoming proposals on development. We are scheduling agenda items for the development workshop.

Council had 13 Priorities that you identified last March, and the City has completed 10 of those priorities. The remaining 3 will be presented now that the legislative updates have been completed.

8. Reports, Announcements, or Requests from Councilmembers.

Burttschell	Absent
Zapalac	Late/Flexible (for attending a workshop)
Curry	Flexible (for attending a workshop)
Miller	Late (for attending a workshop) Discussion on Electric Scooters and Bikes Email Survey link out to folks
Noack	Flexible (for attending a workshop) Ask TxDOT about the Sealy, Texas sign
Lerma	Flexible (for attending a workshop)
Bilski	None

J. Adjourn

A motion was made by Councilwoman Lerma to Adjourn.
Councilman Zapalac seconded the motion. Mayor Bilski called for the vote.

AYES: Bilski, Lerma, Noack, Miller, Curry, Zapalac
NOES: None

The motion carried. The City Council meeting adjourned at 6:54 p.m.

PASSED AND APPROVED this 3rd day of March 2026.

Carolyn Bilski, Mayor

ATTEST:

Sandra Vrabec, City Secretary

b)

ORDINANCE NO. 2026

AN ORDINANCE OF THE CITY COUNCIL OF THE CITY OF SEALY, TEXAS, AMENDING CALLING AND ORDERING A GENERAL ELECTION TO BE HELD ON MAY 2, 2026, FOR THE PURPOSE OF ELECTING MAYOR AND ONE (1) COUNCILMEMBER; DESIGNATING THE POLLING PLACE FOR SUCH ELECTION; PROVIDING THE FORM OF THE BALLOT FOR SUCH ELECTIONS; DIRECTING THE GIVING OF NOTICE OF SUCH ELECTIONS; AND PROVIDING DETAILS RELATING TO THE HOLDING OF SUCH ELECTIONS.

BE IT ORDAINED BY THE CITY COUNCIL OF THE CITY OF SEALY, TEXAS:

Section 1. In accordance with the general laws and Constitution of the State of Texas, a General Election is hereby called and ordered for May 2, 2026, at which election all qualified voters of the City may vote for the purpose of electing the following officials of the City:

**MAYOR
COUNCILMEMBER, PLACE 1**

Section 3. No person's name shall be placed upon the official ballot as a candidate for the above-mentioned position unless such person has filed his or her sworn application, as provided by the TEXAS ELECTION CODE, with the City Secretary of this City at the City of Sealy Municipal Building, 415 Main Street, Sealy, Texas 77474, not later than five o'clock (5:00) p.m. on February 13, 2026. The City Secretary shall note on the face of each such application the date and time of its filing. Such application shall include the office the candidate is seeking.

Section 4. The present boundaries of the City constitute one (1) election precinct, which shall be designated Election Precinct "A" and includes all of Austin County Election Precinct Nos. 307, 408, and 409 that lie within the city limits of the City of Sealy. The polls shall be open for voting from seven o'clock (7:00) a.m. until seven (7:00) p.m. at the following polling place:

POLLING PLACE
W. E. Hill Community Center
1000 Main Street
Sealy, Texas 77474

ORDINANCE NO. 2026

Section 5. Kim Rinn, Austin County Election Official, is hereby appointed clerk for early voting; the appointment of the Election Judge, clerks, or other required appointments shall be made by Kim Rinn in accordance with the TEXAS ELECTION CODE.

W. E. Hill Community Center (Main Early Voting)
1000 Main Street
Sealy, Texas 77474

is hereby designated as the place for early voting for such election. Said clerks shall keep said office open during the hours from eight o'clock (8:00) a.m. until five o'clock (5:00) p.m., on each day for early voting which is not a Saturday, a Sunday, or an official state or federal holiday, beginning on the twelfth (12th) day preceding the date of such election being April 20, 2026, and continuing through the fourth (4th) day preceding the date of such election being April 28, 2026, or as required by law. Said clerks shall not permit anyone to vote early by personal appearance at any time when such office is not open to the public. The place to which ballot applications and ballots voted by mail may be sent is 804 East Wendt Street, Bellville, Texas 77418. Early voting clerk name and address is Kim Rinn, 804 East Wendt Street, Bellville, Texas 77418. The early voting clerk, in accordance with the provisions of the TEXAS ELECTION CODE, shall maintain a roster listing of each person who votes early by personal appearance and each person to whom a ballot to be voted by mail is sent. The roster shall be maintained in a form approved by the Secretary of State.

Section 6. All ballots shall be prepared in accordance with the TEXAS ELECTION CODE. Direct Recording Electronic (DRE) voting machine(s) shall be used for early voting and for voting on Election Day. All expenditures necessary for the conduct of the election and the purchase of materials therefore are hereby authorized.

Section 7. Kim Rinn, Austin County Elections Official, is hereby authorized and directed to furnish all necessary election supplies to conduct such election.

Section 8. Pursuant to the TEXAS ELECTION CODE, write-in votes cast in the Municipal Election shall not be counted unless the name written in appears on the list of write-in

ORDINANCE NO. 2026

candidates. To be entitled to a place on the list of write-in candidates, a candidate must make a declaration of write-in candidacy. Such declaration is to be filed with the City Secretary not later than five o'clock (5:00) p.m. on February 17, 2026, and all of said declarations shall be submitted as required by law.

Section 9. The candidate receiving a majority of votes in the position to be filled in the Municipal Election shall be declared elected to such position.

Section 10. The order in which the names of the candidates are to be printed on the ballot for the Municipal election shall be determined by a drawing by the City Secretary, as provided by Section 52.094 of the TEXAS ELECTION CODE. The City Secretary shall post a notice in her office of the date, hour, and place of drawing. Such notice shall remain posted continuously for seventy-two (72) hours immediately preceding the scheduled time of the drawing, and personal notice shall also be given to any candidate who makes written request for such notice and furnishes to the City Secretary a self-addressed, stamped envelope. Each candidate involved in the drawing, or a designated representative, shall have a right to be present and observe the drawing.

Section 11. Notice of this election shall be given in accordance with the provision of the TEXAS ELECTION CODE and returns of such notice shall be given in accordance with the provisions of the TEXAS ELECTION CODE, and returns of such notice shall be made as provided for in said Code. The Mayor shall issue all necessary orders and writs for such elections, and returns of such election shall be made to the City Secretary immediately after the closing of the polls.

Section 12. Such election shall be held in accordance with the TEXAS ELECTION CODE and the Federal Voting Rights Act of 1965, as amended. Orders are attached hereto as Exhibit "A."

ORDINANCE NO. 2026

PASSED, APPROVED, AND ADOPTED this 3rd day of March 2026.

Carolyn Bilski, Mayor

ATTEST:

Sandra Vrabec, City Secretary

Applications for ballot by mail shall be mailed to:
(Las solicitudes para boletas que se votarán adelantada por correo deberán enviarse a:)

Kim Rinn

Name of Early Voting Clerk
(Nombre del Secretario/a de la Votación Adelantada)

804 E. Wendt Street

Address (Dirección)

Bellville

City (Ciudad) Zip Code (Código Postal)

(979) 865-8633

Telephone Number (Número de teléfono)

krinn@austincounty.com

Email Address (Dirección de Correo Electrónico)

<https://austincounty.com/page/austin.election>

Early Voting Clerk's Website (Sitio web del Secretario/a de Votación Adelantada)

Applications for Ballots by Mail (ABBMs) must be received no later than the close of business on:
(Las solicitudes para boletas que se votarán adelantada por correo deberán recibirse no más tardar de las horas de negocio el:)

04 / 20 / 2026
(date)(fecha)

Federal Post Card Applications (FPCAs) must be received no later than the close of business on:
(La Tarjeta Federal Postal de Solicitud deberán recibirse no más tardar de las horas de negocio el:)

04 / 20 / 2026
(date)(fecha)

Issued this 03 day of 03, 20 26
(day) (month) (year)

(Emitida este día 03 de 03, 20 26.)
(día) (mes) (año)

Signature of Mayor (Firma del Alcalde)

Signature of Councilperson
(Firma del Concejal)

Signature of Councilperson
(Firma del Concejal)

Signature of Councilperson
(Firma del Concejal)

Signature of Councilperson
(Firma del Concejal)

Signature of Councilperson
(Firma del Concejal)

Signature of Councilperson
(Firma del Concejal)

Signature of Councilperson
(Firma del Concejal)

Signature of Councilperson
(Firma del Concejal)

Signature of Councilperson
(Firma del Concejal)

Signature of Councilperson
(Firma del Concejal)

Instruction Note: A copy of this election order must be delivered to the County Clerk/Elections Administrator and Voter Registrar not later than 60 days before election day.
Nota de Instrucción: Se deberá entregar una copia de esta orden de elección al/a la Secretario(a) del Condado/Administrador(a) de Elecciones y el/la Registrador(a) de Votantes a más tardar 60 días antes del día de elección.

Applications for ballot by mail shall be mailed to:
(Las solicitudes para boletas que se votarán adelantada por correo deberán enviarse a:)

Kim Rinn

Name of Early Voting Clerk
(Nombre del Secretario/a de la Votación Adelantada)

804 E. Wendt Street

Address (Dirección)

Bellville

City (Ciudad) Zip Code (Código Postal)

(979) 865-8633

Telephone Number (Número de teléfono)

krinn@austincounty.com

Email Address (Dirección de Correo Electrónico)

<https://austincounty.com/page/austin.election>

Early Voting Clerk's Website (Sitio web del Secretario/a de Votación Adelantada)

Applications for Ballots by Mail (ABBMs) must be received no later than the close of business on:
(Las solicitudes para boletas que se votarán adelantada por correo deberán recibirse no más tardar de las horas de negocio el:)

04 / 20 / 2026
(date)(fecha)

Federal Post Card Applications (FPCAs) must be received no later than the close of business on:
(La Tarjeta Federal Postal de Solicitud deberán recibirse no más tardar de las horas de negocio el:)

04 / 20 / 2026
(date)(fecha)

Issued this 03 day of 03, 20 26
(day) (month) (year)

(Emitida este día 03 de 03, 20 26.)
(día) (mes) (año)

Signature of Mayor (Firma del Alcalde)

Signature of Councilperson
(Firma del Concejal)

Signature of Councilperson
(Firma del Concejal)

Signature of Councilperson
(Firma del Concejal)

Signature of Councilperson
(Firma del Concejal)

Signature of Councilperson
(Firma del Concejal)

Signature of Councilperson
(Firma del Concejal)

Signature of Councilperson
(Firma del Concejal)

Signature of Councilperson
(Firma del Concejal)

Signature of Councilperson
(Firma del Concejal)

Signature of Councilperson
(Firma del Concejal)

Instruction Note: A copy of this election order must be delivered to the County Clerk/Elections Administrator and Voter Registrar not later than 60 days before election day.
Nota de Instrucción: Se deberá entregar una copia de esta orden de elección al/a la Secretario(a) del Condado/Administrador(a) de Elecciones y el/la Registrador(a) de Votantes a más tardar 60 días antes del día de elección.

c)

Will be provided later

d)



AGENDA ITEM NO:

SUBMITTED BY: Patrick Parsons, Public Works Director

MEETING DATE: March 3, 2026

STAFF REPORT

DESCRIPTION

Approve a Resolution for Public Works Salvage Property of Pool Furniture.

ANALYSIS

We have the old furniture from when the pool was open that we do not use therefore it is taking up room in our storage. We have no intentions in using the furniture as it is very worn out and has damages.

RECOMMENDATION

Staff recommends approval of a Resolution for Public Works Salvage Property of Pool Furniture.

FINANCIAL IMPACTS

RESOLUTION 2026

**A RESOLUTION OF THE CITY COUNCIL OF THE CITY OF SEALY,
TEXAS, DECLARING CERTAIN PERSONAL PROPERTY TO BE
SALVAGE PROPERTY AND ORDERING ITS DISPOSAL.**

* * * * *

WHEREAS, The City Council of the City of Sealy, Texas, ("City"), finds that certain personal property has no value, is useless, and should be declared salvage property and disposed of;

NOW THEREFORE, BE IT RESOLVED BY THE CITY COUNCIL OF THE CITY OF SEALY, TEXAS:

Section 1. The facts and recitations contained in the preamble of this Resolution are true and correct and incorporated herein for all purposes.

Section 2. The property on Exhibit "A", which is attached hereto and incorporated herein for all purposes, is declared to be salvage property, useless, and shall be disposed of by being sold as scrap metal or disposed of by a method approved by the City Manager, including public auction.

Section 3. *Severability.* In the event any clause, phrase, provision, sentence or part of this Resolution or the application of the same to any person or circumstances shall for any reason be adjudged invalid or held unconstitutional by a court of competent jurisdiction, it shall not affect, impair, or invalidate this Resolution as a whole or any part or provision hereof other than the part declared to be invalid or unconstitutional; and the city council of the City of Sealy, Texas, declares that it would have passed each and every part of the same notwithstanding the omission of any part thus declared to be invalid or unconstitutional, or whether there be one or more parts.

Section 4. *Repeal.* All resolutions or parts of resolutions in conflict herewith shall be and are hereby repealed only to the extent of such conflict.

Section 5. *Effective Date.* This Resolution shall become effective immediately upon passage.

PASSED and APPROVED this, the 3rd day of March, 2026.

Carolyn Bilski, Mayor

ATTEST:

Sandra Vrabec, City Secretary









e)



AGENDA ITEM NO: _____

SUBMITTED BY: Patrick Parsons, Public Works Director

MEETING DATE: March 3, 2026

STAFF REPORT

DESCRIPTION

Approving a Flock Camera Contract, adding to City Property.

ANALYSIS

The City proposes installing a **Flock Live View camera system** to promote safety and security around City property. These cameras provide real-time visibility and automatically alert on-duty officers to the presence of people and vehicles in the area, allowing for timely awareness and response when needed. The units are solar powered, enabling flexible placement without the need for electrical infrastructure, and they can be accessed remotely by authorized users only. The cameras include pan-tilt-zoom (PTZ) functionality to allow staff to monitor activity as necessary. These devices are **not** automated license plate readers (ALPRs) and do not capture or process license plate information.

RECOMMENDATION

Staff recommends Approval of the Installation of a Flock Live View Camera System to promote safety and security.

FINANCIAL IMPACTS

This camera will be \$4,000.00 per year/per camera. We will code it to Dues and Subscriptions out of Building Services (10-550-53300).

flock safety

Shape a safer future, together

Serving more than

4,000

law enforcement
agencies in 48 states

Helping to solve

14%

reported crime
in the USA



Video Surveillance

- **Guardian Mode:** Set up the camera to proactively alert you when it detects car or human motion.
- **Storage:** Database holds the video for 30 days for detective work and can be downloaded to save for longer.
- **PTZ:** Pan / Tilt / Zoom to cover a wide area. We can zoom up to a quarter mile with 360 degrees of visibility
- **Detect & Follow:** Once the camera detects motion in guardian mode it will follow the person until leave the scope of vision.
- **Position:** Pre-select when and where the camera will look

flock safety

Solar-Powered Condor PTZ

⚠ People Detection
Activity in Parking Lot
After Hours

AI



Infrastructure-Free Video, Ready for Any Location



Improved situational awareness with ultra wide (90 deg) FOV view with frame indicating zoomed in area



Zoomed in view (5 deg FOV zoom)

flock safety
Solar PTZ



Product	QTY	Total Price
Video Surveillance Camera - (\$4,000/year)	1	\$4,000
One Time Installation Fee (100% Discount on PREMIUM) \$1,000	1	INCLUDED
Recurring Flock Cost		\$4,000
INCLUDES - Hardware / Service / Install / Permitting / Updates / No big capital expense / Sim Card LTE / Data Storage		

Motion is detected as a car enters the parking lot - PD is alerted and the person in motion is followed by the camera automatically.





Thank You

“In my 25 years, the Flock Safety system is the single **most important technology** in policing that has come out.”

CHIEF RUSH
Trussville PD (AL)

“I really feel like this technology is **the best thing** — or at least one of the best things — since the police radio. It's been a game changer.”

CHIEF SCESNEY
Grand Prairie PD (TX)

“This is the **single greatest change** since DNA — what this system does is a game changer.”

CHIEF MURRAY
Yakima PD (WA)

“Flock Safety is **the single best tool** I have seen in 30 years - enabling true community policing.”

CHIEF VANHOOZER
Cobb County PD (GA)

“Our ability to fight crime has **easily doubled** just by introducing Flock Safety's tools.”

SGT. SHIPP
Fort Worth PD (TX)

flock safety

Solar-Powered Condor PTZ



People Detection
Activity in Parking Lot
After Hours

AI

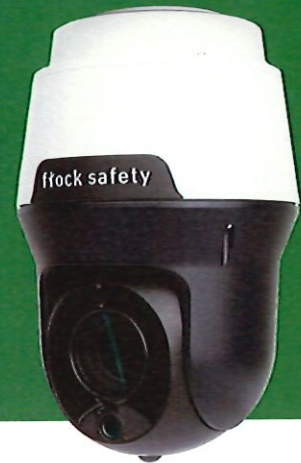

Infrastructure-Free Video, Ready for Any Location

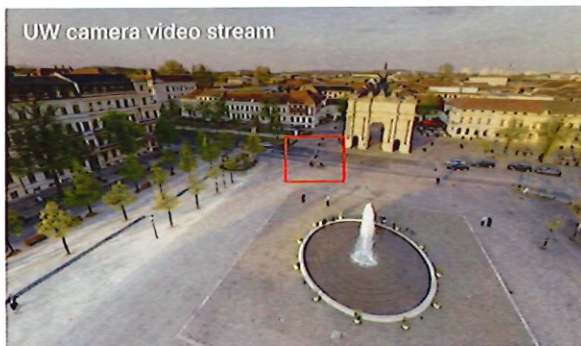

Improved situational awareness with ultra wide (90 deg) FOV view with frame indicating zoomed in area

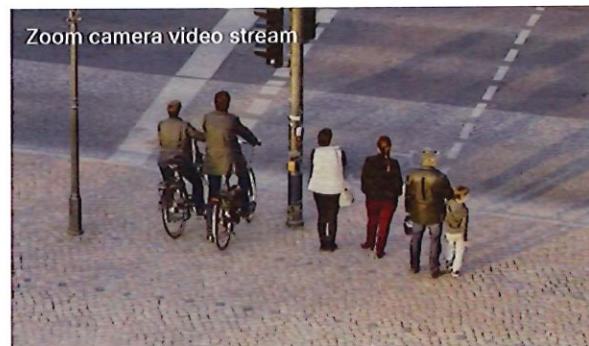

Zoomed in view (5 deg FOV zoom)



NO POWER? NO PROBLEM.

The Condor PTZ is solar-powered and LTE-enabled, so you can place it where it counts—no cables, no hassle.



DUAL LENSES FOR FULL COVERAGE

Get the full picture in one go, capturing both the broad view and the critical close-ups for simultaneous viewing.



ZERO MAINTENANCE, FULL SUPPORT

We handle all the upkeep. No downtime, no distractions. You get reliable, 24/7 coverage without adding to your team's workload.

flock safety

flocksafety.com

(866) 901-1781 | support@flocksafety.com

Why Go with the Condor PTZ?

- ✓ **FLEXIBLE PLACEMENT ANYWHERE, ANYTIME**
The Condor PTZ eliminates power constraints. Install it wherever you need visibility, from active patrol zones to harder-to-reach locations.
- ✓ **ALWAYS ON, ALWAYS COVERED**
With maintenance and support included, you'll get continuous, dependable coverage. Just set it up and let it run—no IT overhead needed.
- ✓ **BOTH BROAD AND FOCUSED VIEWS**
Get wide views and zoomed-in details in one camera. Ideal for monitoring high-traffic and high-risk areas.



What You Get

- ✓ **EFFICIENT USE OF PERSONNEL**
Real-time alerts help officers respond faster, spending less time on screens and more time on patrol.
- ✓ **FASTER CASE RESOLUTIONS**
Clear, continuous video means solid evidence, helping you close cases quicker.
- ✓ **NO EXTRA WORK**
Solar power and full support mean no complex installs or maintenance headaches. Just reliable, round-the-clock coverage.

Ready to boost situational awareness without straining resources?
Contact us today to see how the Solar-Powered Condor PTZ can enhance your safety strategy.

H. PUBLIC HEARING

PUBLIC HEARING NOTICE

Public Hearing: The City Council for the City of Sealy, Texas, will hold a Public Hearing on Amending the 2025-2026 Fiscal Year Budget of the City of Sealy, Texas, to be held on the 3rd day of March, at 6:00 p.m. in the City Council Chamber located at 415 Main Street, Sealy, Texas 77474. All interested persons shall be given an opportunity to be heard for or against any item or the amount of any item contained in the Proposed Budget Amendment.

I. BUSINESS

ITEM #1



AGENDA ITEM NO:

Discussion and Possible Action regarding an Ordinance for Amending the FY 2025-2026 Budget.

SUBMITTED BY: Jennifer Matura, Finance Director

MEETING DATE: March 3rd, 2026

STAFF REPORT

SUMMARY

Staff is requesting Council consideration of a budget amendment to the FY 2026 adopted budget to recognize grant revenue and related expenditures for the Police Department associated with a federal radio upgrade reimbursement grant.

ANALYSIS

On September 29, 2025, the Police Department was awarded a federal grant in the amount of \$125,910.80 from the U.S. Department of Justice, Office of Justice Programs, Bureau of Justice Assistance through the DJ-Edward Byrne Memorial Justice Assistance Grant Program.

There is no local match requirement for this grant, however, it is a reimbursement-based grant. The Police Department purchased upgraded radio equipment from Motorola Solutions, and the expenditure was charged to 10-530-56110 for Radio & Radar Equipment.

The City submitted the final reimbursement request on February 9, 2026, and received reimbursement in the amount of \$125,660.68 on February 17, 2026.

Because the grant award and reimbursement occurred after adoption of the FY 2026 budget, a budget amendment is needed to reflect both the revenue and corresponding expenditure.

This budget amendment will increase the Federal Grant Revenue account (10-43600) by \$125,661, and increase the Radio & Radar Equipment account (10-530-56110) by \$125,661.

This amendment does not impact the General Fund balance, as the expenditure is fully offset by grant revenue.

FINANCIAL IMPACT

Revenue and expenditure both increase by \$125,661 with no impact to fund balance

RECOMMENDATION

Staff recommends approval of the FY 2026 budget amendment.

ORDINANCE 2026 –

AN ORDINANCE OF THE CITY COUNCIL OF THE CITY OF SEALY, TEXAS, AMENDING THE BUDGET OF THE CITY OF SEALY, TEXAS, FOR THE FISCAL YEAR 2025-2026; PROVIDING FOR SEVERABILITY; CONTAINING OTHER PROVISIONS RELATING TO THE SUBJECT; PROVIDING FOR SEVERABILITY; AND PROVIDING AN EFFECTIVE DATE.

WHEREAS, the City of Sealy, Texas Fiscal Year 2025-2026 Budget was adopted within the time and in the manner required by State Law; and

WHEREAS, the City Council hereby finds and determines that certain budget amendments are required to be adopted for the Fiscal Year 2025-2026 Budget; and

WHEREAS, the City Council finds and determines that the proposed changes in the budget are for municipal purposes, and that the amendments of the budget are an emergency and matter of public necessity requiring the adoption of the amendments to the budget at this time.

NOW THEREFORE, BE IT ORDAINED BY THE CITY COUNCIL OF THE CITY OF SEALY, TEXAS:

Section 1. The facts and matters set forth in the preamble of this ordinance are found to be true and correct and incorporated herein for all purposes.

Section 2. The City of Sealy, Texas Fiscal Year 2025-2026 Budget is hereby amended to the Budget of the City of Sealy, Texas for the Fiscal Year 2025-2026 shall be attached to and made a part of the Original Budget by the City Secretary and filed as required by State Law.

Section 3. In the event any clause, phrase, provision, sentence, or part of this Ordinance or the application of the same to any person or circumstance shall for any reason be adjudged invalid or held unconstitutional by a court of competent jurisdiction, it shall not affect, impair, or invalidate this Ordinance as a whole or any part or provision hereof other than the part declared to be invalid or unconstitutional, and the City Council of the City of Sealy, Texas, declares that it would have passed each and every part thus declared to be invalid or unconstitutional whether there be one or more parts.

Section 4. This Ordinance shall be effective immediately upon passage.

PASSED AND APPROVED AND ADOPTED this 3rd day of March 2026.

Carolyn Bilski, Mayor

ATTEST:

Sandra Vrablec, City Secretary

Statement of Grant Award

Statement of Grant Award (SOGA)

The Statement of Grant Award is the official notice of award from the Office of the Governor (OOG). This Grant Agreement and all terms, conditions, provisions and obligations set forth herein shall be binding upon and shall inure to the benefit of the Parties and their respective successors and assigns and all other State of Texas agencies and any other agencies, departments, divisions, governmental entities, public corporations, and other entities which shall be successors to each of the Parties or which shall succeed to or become obligated to perform or become bound by any of the covenants, agreements or obligations hereunder of each of the Parties hereto.

The approved project narrative and budget for this award are reflected in eGrants on the 'Narrative' and 'Budget/Details' tabs. By accepting the Grant Award in eGrants, the Grantee agrees to strictly comply with the requirements and obligations of this Grant Agreement including any and all applicable federal and state statutes, regulations, policies, guidelines and requirements. In instances where conflicting requirements apply to a Grantee, the more restrictive requirement applies.

The Grant Agreement includes the Statement of Grant Award; the OOG Grantee Conditions and Responsibilities; the Grant Application in eGrants; and the other identified documents in the Grant Application and Grant Award, including but not limited to: 2 CFR Part 200, Uniform Administrative Requirements, Cost Principles, and Audit Requirements for Federal Awards; Chapter 783 of the Texas Government Code, Title 34, Part 1, Chapter 20, Subchapter E, Division 4 of the Texas Administrative Code, and the Texas Grant Management Standards (TxGMS) developed by the Comptroller of Public Accounts; the state Funding Announcement or Solicitation under which the grant application was made, and for federal funding, the Funding Announcement or Solicitation under which the OOG was awarded funds; and any applicable documents referenced in the documents listed above. For grants awarded from the U.S. Department of Justice, the current applicable version of the Department of Justice Grants Financial Guide and any applicable provisions in Title 28 of the CFR apply. For grants awarded from the Federal Emergency Management Agency (FEMA), all Information Bulletins and Policies published by the FEMA Grants Program Directorate apply. The OOG reserves the right to add additional responsibilities and requirements, with or without advance notice to the Grantee.

By clicking on the 'Accept' button within the 'Accept Award' tab, the Grantee accepts the responsibility for the grant project, agrees and certifies compliance with the requirements outlined in the Grant Agreement, including all provisions incorporated herein, and agrees with the following conditions of grant funding. The grantee's funds will not be released until the grantee has satisfied the requirements of the following Condition(s) of Funding and Other Fund-Specific Requirement(s), if any, cited below:

Grant Number:	5335601	Award Amount:	\$125,910.80
Date Awarded:	9/29/2025	Grantee Cash Match:	\$0.00
Grant Period:	10/01/2025 - 06/30/2026	Grantee In Kind Match:	\$0.00
Liquidation Date:	09/28/2026	Grantee GPI:	\$0.00
Program Fund:	DJ-Edward Byrne Memorial Justice Assistance Grant Program	Total Project Cost:	\$125,910.80
Grantee Name:	Sealy, City of		
Project Title:	Radio Upgrade		
Grant Manager:	Joshua Pent		
Unique Entity Identifier (UEI):	MTVLL1N4MGA7		

CFDA:	16.738 - Edward Byrne Memorial Justice Assistance Grant Program
Federal Awarding Agency:	U.S. Department of Justice, Office of Justice Programs, Bureau of Justice Assistance
Federal Award Date:	9/25/2023
Federal/State Award ID Number:	15PBJA-23-GG-03034-JAGX
Total Federal Award/State Funds Appropriated:	\$16,452,044.00
Pass Thru Entity Name:	Texas Office of the Governor -- Criminal Justice Division (CJD)
Is the Award R&D:	No
Federal/State Award Description:	The purpose of this program is to reduce crime and improve the criminal justice system.

Receipt of Grant Funds



02/17/2026 12:06:22 PM

You are logged in as:

Texas Identification Number:
17460031408
Jennifer Matura
jmatura@ci.sealy.tx.us
(979) 472-8909
IP: 204.64.105.155

System Tools

- Sign up for Advanced Payment Notifications Emails
- Paying Agency Contact List
- Back to eSystems Menu

Public Payment Resources

- State Vendor Payment Resources
- Where the Money Goes
- Open Records Division

Payment Information

Tips:

* Both the Invoice Number and Invoice Description fields display information provided by the paying agency. Contact the paying agency for additional information if needed.
[Paying Agency Contact List](#)

Texas Identification Number	Mail Code	Payment Number	Payment Type	Paying Agency	Total
17460031408	004	5922557	DD	300	125660.68

Document Number	Invoice Number	Invoice Description	Invoice Amount	Interest Amount
9G060275	5335601_20260211	RADIO UPGRADE	125,660.68	0.00

[New Payment Search](#)

[Back](#)

texas.gov | [Texas Records and Information Locator \(TRAIL\)](#) | [State Link Policy](#) | [Texas Homeland Security](#) | [Texas Veterans Portal](#)

Kelly Hancock, Acting Texas Comptroller of Public Accounts • [Home](#) • [Contact Us](#)
[Privacy and Security Policy](#) | [Accessibility Policy](#) | [Link Policy](#) | [Public Information Act](#) | [Compact with Texans](#)



Agency Information

02/17/2026 12:06:02 PM

You are logged in as:

Texas Identification Number:
17460031408
Jennifer Matura
jmatura@ci.sealy.tx.us
(979) 472-8909
IP: 204.64.105.155

System Tools

- Sign up for Advanced Payment Notifications Emails 
- Paying Agency Contact List
- Back to eSystems Menu

Public Payment Resources

- State Vendor Payment Resources
- Where the Money Goes
- Open Records Division

Agency Number

300

Agency Name and Contact

GOVERNOR - FISCAL
STACY KNAUSE
SENIOR ACCOUNTS PAYABLE ACCOUNTANT

Phone: 512-463-9274
Toll Free:
Fax: 512-463-4114
Email: stacy.knause@gov.texas.gov

[Back](#)

[texas.gov](https://www.texas.gov) | [Texas Records and Information Locator \(TRAIL\)](#) | [State Link Policy](#) | [Texas Homeland Security](#) | [Texas Veterans Portal](#)
Kelly Hancock, Acting Texas Comptroller of Public Accounts • [Home](#) • [Contact Us](#)
[Privacy and Security Policy](#) | [Accessibility Policy](#) | [Link Policy](#) | [Public Information Act](#) | [Compact with Texans](#)



ACH Receive Report

Standard ACH Receive Report

As of 02/17/2026

Company: CITY OF SEALY, TEXAS

User: Jennifer Matura

02/17/2026 10:04 AM ET

Commercial Electronic Office®

Treasury Information Reporting

Currency: USD

Bank: 111900659

Account: ██████████ (TX)

WELLS FARGO BANK, N.A.
2025 Tax/Rev COs I & S Fund

No data available for this account

Currency: USD

Bank: 111900659

Account: ██████████ (TX)

WELLS FARGO BANK, N.A.
Payroll Clearing Account

Debit Amount

Transaction Details

812.78	Entry Class/Description: CCD/AUTOSETTLE	Discretionary Data: N/A
	Sending Company ID: 7460031401	Sending Co Name: CITY OF SEALY TX
	Recipient ID: FILE 7460031401	Recipient Name: ACH AUTO SETLMNT
	Trace Number: 000013120533	
	Unique ID: 00000091006162701970	
	Bank Reference: 000013120533	
	Addenda Info: ACH ORIGINATION - CITY OF SEALY TX - FILE 7460031401 COID 7460031401 0652000013120533	

Account Net Total ██████████ USD: -812.78

Currency: USD

Bank: 111900659

Account: ██████████ X)

WELLS FARGO BANK, N.A.
General Operating Account

No data available for this account

Currency: USD

Bank: 111900659

Account: ██████████ TX)

WELLS FARGO BANK, N.A.
I and S Funds Clearing Acct

Credit Amount

Transaction Details

2,674.09	Entry Class/Description: PPD/Entities	Discretionary Data: N/A
	Sending Company ID: 2742079879	Sending Co Name: AUSTIN CO AD2
	Recipient ID:	Recipient Name: CITY OF SEALY - IS
	Trace Number: 201277378480	
	Unique ID: 00000091006162313945	
	Bank Reference: 201277378480	

Account Net Total ██████████ USD: 2,674.09

Currency: USD

Bank: 111900659

Account: ██████████ TX)

WELLS FARGO BANK, N.A.
Special Account

Credit Amount

Transaction Details

125,660.68	Entry Class/Description: CTX/INV-PAYMTS	Discretionary Data: N/A
	Sending Company ID: 1746000089	Sending Co Name: GOVERNOR FISCAL
	Recipient ID: 17460031408004	Recipient Name: 0007CITY OF SEALY
	Trace Number: 000026548674	
	Unique ID: 00000091006071856749	
	Bank Reference: 000026548674	
	Addenda Info: ISA 00 0000000000 00 0000000000 ZZ 1746000089 ZZ JPMORGAN CHASE 260212 20500016548674	
3,049.25	Entry Class/Description: PPD/Entities	Discretionary Data: N/A
	Sending Company ID: 2742079879	Sending Co Name: AUSTIN CO AD2
	Recipient ID:	Recipient Name: CITY OF SEALY - MO

Budget Amendment

2-17-2026 12:18 EM
 PACKET: 00444-Radio Grant 03/03/2026 JM
 BUDGET CODE: CB-Current Budget

BUDGET ADJUSTMENT REGISTER

PAGE: 1

FUND ACCOUNT	DATE	DESCRIPTION	ADJUSTMENT	ORIGINAL BUDGET	PREVIOUS ADJUSTMENTS	NEW BUDGET	BUDGET BALANCE

Budget Adj. # 000611							
10 43600	3/03/2026	Budget Adjustment Federal Grant Proceeds	125,661.00	0.00	0.00	125,661.00-	125,661.00-
10 530-56110	3/03/2026	Budget Adjustment Radio & Radar Equipment	125,661.00	0.00	0.00	125,661.00	0.32
		TOTAL NO. ADJUSTMENTS--REVENUE:			1	125,661.00	
		TOTAL NO. ADJUSTMENTS--EXPENSE:			1	125,661.00	
		TOTAL IN PACKET--				<u>251,322.00</u>	

*** NO WARNINGS ***

*** NO ERRORS ***

*** END OF REPORT ***

ORDINANCE 2026 –

AN ORDINANCE OF THE CITY COUNCIL OF THE CITY OF SEALY, TEXAS, AMENDING THE BUDGET OF THE CITY OF SEALY, TEXAS, FOR THE FISCAL YEAR 2025-2026; PROVIDING FOR SEVERABILITY; CONTAINING OTHER PROVISIONS RELATING TO THE SUBJECT; PROVIDING FOR SEVERABILITY; AND PROVIDING AN EFFECTIVE DATE.

WHEREAS, the City of Sealy, Texas Fiscal Year 2025-2026 Budget was adopted within the time and in the manner required by State Law; and

WHEREAS, the City Council hereby finds and determines that certain budget amendments are required to be adopted for the Fiscal Year 2025-2026 Budget; and

WHEREAS, the City Council finds and determines that the proposed changes in the budget are for municipal purposes, and that the amendments of the budget are an emergency and matter of public necessity requiring the adoption of the amendments to the budget at this time.

NOW THEREFORE, BE IT ORDAINED BY THE CITY COUNCIL OF THE CITY OF SEALY, TEXAS:

Section 1. The facts and matters set forth in the preamble of this ordinance are found to be true and correct and incorporated herein for all purposes.

Section 2. The City of Sealy, Texas Fiscal Year 2025-2026 Budget is hereby amended to the Budget of the City of Sealy, Texas for the Fiscal Year 2025-2026 shall be attached to and made a part of the Original Budget by the City Secretary and filed as required by State Law.

Section 3. In the event any clause, phrase, provision, sentence, or part of this Ordinance or the application of the same to any person or circumstance shall for any reason be adjudged invalid or held unconstitutional by a court of competent jurisdiction, it shall not affect, impair, or invalidate this Ordinance as a whole or any part or provision hereof other than the part declared to be invalid or unconstitutional, and the City Council of the City of Sealy, Texas, declares that it would have passed each and every part thus declared to be invalid or unconstitutional whether there be one or more parts.

Section 4. This Ordinance shall be effective immediately upon passage.

PASSED AND APPROVED AND ADOPTED this 3rd day of March 2026.

Carolyn Bilski, Mayor

ATTEST:

Sandra Vrabec, City Secretary

ITEM #2



AGENDA ITEM NO: 02

Discussion and Possible Action regarding review of the Existing Contract for Voice Over Internet Protocol (VOIP) Services, including Possible Termination, Selection of a Contractor, and Approval of a Contract.

SUBMITTED BY: Jennifer Matura, Finance/HR Director

MEETING DATE: March 3rd, 2026

STAFF REPORT

SUMMARY

The City's current VOIP phone system is scheduled to be discontinued on June 24, 2026, following the end-of-life of the MiCloud by RingCentral platform. Staff has identified an opportunity to consolidate City Hall and Police Department phone services under a single provider. We have received proposals from RingCentral and Verizon (via the Texas DIR Cooperative contract).

RingCentral has submitted an updated consolidated proposal for both departments that results in a lower total cost, includes all required equipment at no charge, waives early termination fees, and has been revised to address the City Attorney's legal concerns.

ANALYSIS

In June 2021, City Council approved entering into a contract with Mitel MiCloud Connect Services after the prior phone system reached end-of-life in December of 2020. The initial contract term was for 36 months, with subsequent 12-month renewals in August 2024 and August 2025.

Following Mitel's acquisition by RingCentral in July 2024, the City's contract was assigned to RingCentral without changes in pricing or services levels. In October 2025, the City received notice that the MiCloud platform would be discontinued effective June 24, 2026, requiring transition to a new system.

Given the required transition, staff evaluated options to:

- Replace the system at City Hall
- Consolidate Police Department phone services under the same provider
- Reduce long-term operating costs
- Minimize operational disruption

RingCentral – RingEx

RingCentral submitted an updated proposal dated February 27, 2026 for consolidated City Hall and Police Department services.

This proposal includes:

- 54 DigitalLine Unlimited Advanced licenses
- 9 additional local numbers
- 25 Mitel phones for PD provide at no cost
- Transfer of ownership of currently leased Mitel equipment to the City
- No implementation and training fees
- Waiver of early termination fees associated with the existing MiCloud agreement
- Contract language revised to Texas governing law approved by the City Attorney

Total Monthly Recurring Services and Fees:

\$1,008 per month

This represents a full consolidation of City Hall and Police Department services under one platform.

Operationally, this option provides a seamless transition. City Hall staff are already familiar with RingCentral's system and administrative portal. Blue Iron will coordinate the installation of the new phones at the Police Department.

Verizon One Talk

Staff also evaluated a proposal from Verizon/Masters Telecom through the Texas DIR Cooperative contract.

The estimated monthly recurring costs was approximately \$1,060 per month. However:

- Early termination fees of approximately \$4,673 would apply for discontinuing the existing MiCloud contract
- Masters Telecom agreement references Florida governing law for installation and support services
- The City Attorney is unable to provide legal guidance regarding Florida governed contractual provisions

While Verizon's services are available under the Texas DIR Cooperative contract, the Masters Telecom installation and support terms present legal uncertainty.

FINANCIAL IMPACT

36-Month Estimated Cost Comparison

Option	Approximate 36-Month Cost
RingCentral	~\$36,288
Verizon	~\$42,833

Estimated savings with RingCentral come out to a little over \$6,500 over 36 months.

RECOMMENDATION

Staff recommends approval to authorize termination of the City's existing MiCloud VOIP services agreement with Ring Central and to approve entering into a 36-month contract with RingCentral, Inc, for consolidated RingEx VOIP services for City Hall and the Police Department.

Approval of this agreement will ensure continuity of communication services at City Hall prior to the June 24, 2026 platform discontinuation.

Ring Central Sales Proposal & Order Form/Contract

(awaiting pricing update on Order Form to
reflect most recent Sales Proposal)



Sales proposal



QUOTE PREPARED FOR
CITY OF SEALY

PREPARED BY
Josh Palmer
Mitel Sales Specialist
josh.palmer@ringcentral.com

Budgetary Quote

Prepared for:

CITY OF SEALY
 415 MAIN St., PO BOX 517
 Sealy TX 77474
 United States

Kimbra Hill

City Manager

khill@ci.sealy.tx.us

979-885-3511

Quote Name:	CITY OF SEALY 1
Quote Creation Date:	October 23 rd , 2025
Quote Expiration Date:	March 27 th , 2026
Estimated Contract Start Date:	March 2 nd , 2026
Initial Term:	36 Months
Renewal Term:	24 Months
Currency:	USD
Payment Plan:	Monthly

RingEX™ Services

Recurring Services			
Summary of Service	Qty	Rate	Subtotal
DigitalLine Unlimited Advanced	54	\$13.50	\$729.00
Additional Local Number	9	\$1.00	\$9.00
Mitel 6930W IP Phone - Rental	25	\$0.00	\$0.00
Monthly Recurring Services Total			\$738.00
Recurring Fees			
Summary of Service	Qty	Rate	Subtotal
e911 Service Fee	54	\$1.00	\$54.00
Compliance and Administrative Cost Recovery Fee	54	\$4.00	\$216.00
Recurring Fees Total			\$270.00
Total Monthly Recurring Services and fees			\$1,008.00

Monthly Recurring Services including Fees	\$1,008.00
One-Time Items Total including Fees	\$0.00
Total Amount*	\$1,008.00

*Amounts are exclusive of applicable Taxes, Fees, and Shipping Charges.



RingCentral Inc., 20 Davis Drive, Belmont, CA 94002, United States

"RingCentral Office" and "RingCentral MVP" are now "RingEX™". All references to "RingCentral Office" and "RingCentral MVP", whether in the Agreement or its attachments, Order Forms or descriptions, mean "RingEX™".





INITIAL ORDER FORM

This Initial Order Form is a binding agreement between RingCentral, Inc. ("RingCentral") and CITY OF SEALY ("Customer" or "You") (together the "Parties"), for the purchase of the Services, licenses, and products listed herein. This Initial Order Form is subject to and incorporates the terms and conditions of: (i) the separate written agreement, executed by the Parties governing the purchase of the Services described in this Order Form, or (ii) the RingCentral Online Terms of Service available at https://www.ringcentral.com/legal/eulatos.html, if there is no written agreement in place (hereinafter (i) and (ii) referred to as the "Agreement"). Capitalized terms not defined herein shall have the same meanings as set forth in the applicable Agreement between the Parties. Unless agreed by both Parties in writing, any terms or conditions set forth in a Customer-issued purchase order or ordering document shall not apply.

Please note that RingCentral MVP is now RingEX. All references to "RingCentral MVP", whether in terms of service, advertising or product descriptions, mean "RingEX".

Customer
CITY OF SEALY

Service Provider
RingCentral, Inc.

415 MAIN St., PO BOX 517
Sealy, TX 77474
United States

20 Davis Drive
Belmont, CA 94002
United States

Kimbra Hill
979-885-3511
khill@ci.sealy.tx.us

Service Commitment Period

- Start Date: February 19, 2026
Initial Term: 36 Months
Renewal Term: 24 Months
Payment Schedule: Monthly

RingEX Services

Table with columns: Summary of Service, Qty, Rate, Subtotal. Includes rows for DigitalLine Unlimited Advanced, Compliance and Administrative Cost Recovery Fee, e911 Service Fee, Additional Local Number, and Total Initial Amount (\$749.00).

*Amounts are exclusive of applicable Taxes, Fees, and Shipping Charges.

Cost Center Billing

For customers with cost center billing, it is the Customer's responsibility to provide cost center allocation information to RingCentral at least 10 days prior to the issuance of the invoice. After the information is received, it will be reflected on future invoices, but will not be adjusted retroactively on past invoices. If purchasing additional services through the administrative portal, it is the Customer's

responsibility to assign cost centers at the time of purchase; otherwise, those services will not be allocated by cost center on the next invoice. Please note that cost center allocation is not available for certain items, such as minute bundles and credit memos. For additional questions, please contact the RingCentral invoice billing team at billingsupport@ringcentral.com.

Free Services Amount

You will receive 2,309.16 US Dollars (the "Free Service Amount"), which will be applied against charges for the recurring Services set forth in this Order Form and any applicable taxes and fees associated with those Services invoiced by RingCentral. The Free Service Amount is non-transferable and non-refundable and will expire upon termination of this Order Form. You will be responsible for paying for any additional services and products ordered, and any applicable associated taxes and fees.

Customer Reference. Customer may promote their use of RingCentral services and agrees that RingCentral may identify customer as a user of the services. All press releases or quotes regarding Customer's use of service will be pre-approved by Customer, which consent will not be unreasonably withheld.

Add-on Services. Customer is responsible for reviewing additional terms and conditions that may apply to RingCentral add-on services (where available) and certain Advanced Support Services listed on this order form, and which are available at <https://www.ringcentral.com/legal/add-on-services.html>.

IN WITNESS WHEREOF, the Parties have executed this Initial Order Form above through their duly authorized representatives.

Customer
CITY OF SEALY

RingCentral
RingCentral, Inc.

By: _____
Name: _____
Title: _____
Date: _____

By: _____
Name: Ayub Mohammed
Title: VP Sales SBG
Date: _____



MASTER SERVICES AGREEMENT

This Master Services Agreement is effective as of the date of last signature ("Effective Date") and made between:

CITY OF SEALY ("Customer")

RingCentral, Inc. ("RingCentral")

Address:

415 MAIN St., PO BOX 517
Sealy, TX 77474

Address:

20 Davis Drive
Belmont, CA 94002

By: _____
Name: _____
Title: _____
Date: _____

By: _____
Name: Ayub Mohammed
Title: VP Sales SBG
Date: _____

RingCentral and Customer are together referred to as the "Parties" and each individually as a "Party."

- 1. The Master Services Agreement ("Agreement") consists of the terms and conditions contained herein, and any Service Attachments applicable to Customer's Services, and any other Attachments agreed by the Parties, are incorporated into and form a part of this Agreement.
Exhibit A – Definitions
Attachment A – RingEX Services

THE PARTIES AGREE AS FOLLOWS:

2. Ordering and Term

- A. Ordering Services. Customer may order the Services set forth in the relevant Attachments, attached hereto, by executing an Order Form in the format provided by RingCentral.
B. Equipment. Subject to availability based on brand and Customer location, Customer may purchase or rent equipment from RingCentral for use with the Services.
C. Term of this Agreement. The Term of this Agreement will commence on the Effective Date and continue until the last Order Form is terminated or expires, unless terminated earlier in accordance with its terms.
D. Services Term. The Services Term will begin on the Start Date of the initial Order Form and continue for the initial term set forth in the initial Order Form ("Initial Term").

Services unless otherwise extended in the applicable Order Form, and will be invoiced on the same billing cycles as the preexisting Services.

3. Invoicing and Payment

- A. **Prices and Charges.** All prices are identified in US dollars on the Administrative Portal or in the applicable Order Form unless otherwise agreed by the Parties. Additional charges may result if Customer activates additional features, exceeds usage thresholds, or purchases additional Services or equipment. Customer will be liable for all charges resulting from use of the Services on its Account. Unless otherwise agreed between the Parties, recurring charges (such as charges for Digital Lines, product licenses, minute bundles, and equipment rental fees) for the Services begin on the Start Date identified in the Administrative Portal or in the applicable Order Form and will remain in effect for the Initial Term (as described in an Order Form) or, if applicable, the then-current Renewal Term. RingCentral will provide notice of any proposed increase in such charges no later than sixty (60) days before the end of the Initial Term or then-current Renewal Term, and any such increase will be effective on the first day of the next Renewal Term. Administrative Fees that RingCentral is entitled to pass on to its customers as a surcharge pursuant to applicable Law may be increased on thirty (30) days' written notice. Outbound calling rates will be applied based on the rate in effect at the time of use. Customer may locate the currently effective rates in the Administrative Portal.
- B. **Invoicing and Payment.** Invoices will be issued in accordance with the payment terms set forth in the Order Form. If Customer chooses to pay by credit or debit card, by providing a valid credit or debit card, Customer is expressly authorizing all Services and equipment charges and fees to be charged to such payment card, including recurring payments billed on a monthly or annual basis. In addition, Customer's provided credit card shall be used for any in-month purchases of additional services and products, or where Customer has exceeded usage or threshold limits, any overage charges. Unless otherwise stated in the applicable Order Form, recurring charges are invoiced in advance in the frequency set forth in the Order Form, and usage-based and onetime charges are billed monthly in arrears. Customer shall make payment in full, without deduction or set-off, within thirty (30) days of the invoice date. Any payment not made when due may be subject to a late payment fee equivalent to the lesser of (i) one and a half percent (1.5%) per month or (ii) if applicable, the highest rate allowed by Law. In no event may payment be subject to delays due to Customer internal purchase order process.
- C. **Taxes.** All rates, fees, and charges are exclusive of applicable Taxes, for which Customer is solely responsible. Taxes may vary based on jurisdiction and the Services provided. If any withholding tax is levied on the payments, then Customer must increase the sums paid to RingCentral so that the amount received by RingCentral after the withholding tax is deducted is the full amount RingCentral would have received if no withholding or deduction had been made. If Customer is a tax-exempt entity, tax exemption will take effect upon provision to and validation by RingCentral of certificate of tax exemption.
- D. **Billing Disputes.** If a Customer reasonably and in good faith disputes any portion of RingCentral's invoice, it must provide written notice to RingCentral within thirty (30) days of the invoice date, identifying the reason for the dispute and the amount being disputed. Customer's dispute as to any portion of the invoice will not excuse Customer's obligation to timely pay the undisputed portion of the invoice. Upon resolution, Customer must pay any validly invoiced unpaid amounts within thirty (30) days. Any amounts that are found to be in error resulting in an overpayment by the Customer will be applied as a billing credit against future invoices. Customer will be reimbursed any outstanding billing credits at the expiration or termination of this Agreement.

4. Provision of the Service

- A. **General Terms.** RingCentral will provide the Services as described in the relevant Service Attachment. RingCentral may enhance, replace, and/or change the features of the Services, but it will not materially reduce the core features, functions, or security of the Services during the Term without Customer's consent.
- B. **Customer Care**
 - i. Customer must provide Helpdesk Support to Customer's End Users. RingCentral may require Customer's Helpdesk Support personnel to complete a designated series of training courses on RingCentral's Services. Such training will be provided to Customer online in English at no cost.
 - ii. RingCentral will make remote support available to Customer's Helpdesk Support personnel and/or Account Administrators via the Customer Care call center, which will be available 24/7, to attempt to resolve technical issues with, and answer questions regarding the use of the Services. Unless otherwise agreed by the parties, Customer Care support will be provided in English, and onsite and implementation services are not included in the Customer Care support.
 - iii. Customer may open a case with Customer Care following the process in place at the time. Any individual contacting Customer Care on behalf of Customer must be authorized to do so on behalf of the Account and will be required to follow applicable authentication protocols.
- C. **Professional Services.** RingCentral offers a broad portfolio of professional services that includes onsite and remote implementation services; extended enterprise services including premium technical support; and consulting. Any such services are governed by this Agreement, the Professional Services terms, and any applicable Statement of Work (SOW), which may be attached hereto.

- D. **Managed Services.** Customer may purchase Managed Services from RingCentral for use with the Services. The terms and conditions that govern the Managed Services can be found at: <https://www.ringcentral.com/legal/managed-services-attachment.html>.
- E. **Subcontracting.** RingCentral may provide any of the Services hereunder through any of its Affiliates or subcontractors, provided that RingCentral will bear the same degree of responsibility for acts and omissions for those subcontractors acting on RingCentral's behalf in the performance of its obligations under this Agreement as it would bear if such acts and omissions were performed by RingCentral directly.

5. Use of the Service

- A. **Service Requirements.** The Services are dependent upon Customer's maintenance of sufficient Internet access, networks, and power as set forth in RingCentral's Technical Sufficiency Criteria, available at <https://www.ringcentral.com/legal/policies/technical-sufficiency-criteria.html>. RingCentral will not be responsible for any deficiencies in the provision of the Services if Customer's network does not meet RingCentral's Technical Sufficiency Criteria.
- B. **Use Policies.** Customer and its End Users may use the Services only in compliance with this Agreement, applicable Law, and the Use Policies referenced below, which are incorporated into and form part of this Agreement. Customer must ensure that its End Users comply with the Use Policies. Any breach of this Section (Use Policies) will be deemed a material breach of this Agreement. RingCentral may update the Use Policies from time to time and will provide notice of material updates to Customer at the email address on file with the Account. All updates will become effective thirty (30) days after such notice to Customer or upon posting for non-material changes. Customer may object to a modification that negatively impacts its use of the Service by sending written notice ("Objection Notice") to RingCentral within thirty (30) days from the date of the notice of modification. If the Parties cannot reach agreement, then either Party may terminate the affected Services without penalty with thirty (30) days written notice to the other Party.
 - i. **Acceptable Use Policy.** The Services must be used in accordance with RingCentral's Acceptable Use Policy, available at <https://www.ringcentral.com/legal/acceptable-use-policy.html>. Notwithstanding anything to the contrary in this Agreement, RingCentral may act immediately and without notice to suspend or limit the Services if RingCentral reasonably suspects fraudulent or illegal activity in the Customer's Account, material breach of the Acceptable Use Policy, or use of the Services that could interfere with the functioning of the RingCentral Network provided such suspension or limitation may only be to the extent reasonably necessary to protect against the applicable condition, activity, or use. RingCentral will promptly remove the suspension or limitation as soon as the condition, activity or use is resolved and mitigated in full. If Customer anticipates legitimate but unusual activity on its Account, Customer should contact Customer Care in advance to avoid any Service disruption.
 - ii. **Emergency Services.** RingCentral's policy governing the provision of emergency services accessed via the Services is available at <https://www.ringcentral.com/legal/emergency-services.html>.
 - iii. **Numbering Policy.** The provision, use, and publication of numbers used in conjunction with the Services are governed by RingCentral's Numbering Policies, available at <https://www.ringcentral.com/legal/policies/numbering-policy.html>.

6. Termination

- A. **Termination for Cause.** Either Party may terminate this Agreement and any Services purchased hereunder in whole or part by giving written notice to the other Party: i) if the other Party breaches any material term of this Agreement and fails to cure such breach within thirty (30) days after receipt of such notice; ii) at the written recommendation of a government or regulatory agency following a change in either applicable Law or the Services; or iii) upon the commencement by or against the other Party of insolvency, receivership or bankruptcy proceedings or any other proceedings or an assignment for the benefit of creditors.
- B. **Effect of Termination.** If Customer terminates the Services, a portion of the Services, or this Agreement in its entirety due to RingCentral's material breach under Section 6(A) (Termination for Cause), Customer will not be liable for any fees or charges for terminated Services for any period subsequent to the effective date of such termination (except those arising from continued usage before the Services are disconnected), and RingCentral will provide Customer a pro-rata refund of any prepaid and unused fees or charges paid by Customer for terminated Services. If this Agreement or any Services are terminated for any reason other than as a result of a material breach by RingCentral or as otherwise permitted pursuant to Section 6(A) or as set forth in Section 14(I) (Regulatory and Legal Changes) the Customer must, to the extent permitted by applicable Law and without limiting any other right or remedy of RingCentral, pay within thirty (30) days of such termination all amounts that have accrued prior to such termination, as well as all sums remaining unpaid for the Services for the remainder of the then-current Term plus related Taxes and fees.

7. Intellectual Property

A. Limited License

- i. Subject to, and conditional upon Customer's compliance with, the terms of this Agreement, RingCentral grants to Customer and its End User, a limited, personal, revocable, non-exclusive, non-transferable (other than as permitted under this Agreement), non-sublicensable license to use any software provided or made available by RingCentral to the Customer as part of the Services ("Software") to the extent reasonably required to use the Services as permitted by this Agreement, only for the duration that Customer is entitled to use the Services and subject to the Customer being current on its payment obligations.

- ii. Customer will not, and will not allow its End Users, to: (a) sublicense, resell, distribute or assign its right under the license granted under this Agreement to any other person or entity; (b) modify, adapt or create derivative works of the Software or any associated documentation; (c) reverse engineer, decompile, decrypt, disassemble or otherwise attempt to derive the source code for the Software; (d) use the Software for infringement analysis, benchmarking, or for any purpose other than as necessary to use the Services Customer is authorized to use; (e) create any competing Software or Services; or (f) remove any copyright or other proprietary or confidential notices on any Software or Services.

B. IP Rights

- i. **RingCentral's Rights.** Except as expressly provided in this Agreement, the limited license granted to Customer under Section 7(A) (Limited License) does not convey any ownership or other rights or licenses, express or implied, in the Services (including the Software), any related materials, or in any Intellectual Property and no IP Rights or other rights or licenses are granted, transferred, or assigned to Customer, any End User, or any other party by implication, estoppel, or otherwise. All rights not expressly granted herein are reserved and retained by RingCentral and its licensors. The Software and Services may comprise or incorporate services, software, technology, or products developed or provided by third parties, including open-source software or code. Customer acknowledges that misuse of RingCentral Services may violate third-party IP rights.
- ii. **Customer Rights.** As between RingCentral and Customer, Customer retains title to all IP Rights that are owned by the Customer or its suppliers. To the extent reasonably required or desirable for the provision of the Services, Customer grants to RingCentral a limited, personal, non-exclusive, royalty-free, license to use Customer's IP Rights in the same. Customer must provide (and is solely responsible for providing) all required notices and obtaining all licenses, consents, authorizations, or other approvals related to the use, reproduction, transmission, or receipt of any Customer Content that includes personal or Confidential Information or incorporates any third-party IP rights.

- C. **Use of Marks.** Neither Party may use or display the other Party's trademarks, service mark or logos in any manner without such Party's prior written consent.

8. Confidentiality

- A. **Restrictions on Use or Disclosures by Either Party.** Subject to the Texas Public Information Act and Texas State Record Retentions Laws, during the Term of this Agreement and for at least one (1) year thereafter, the Receiving Party shall hold the Disclosing Party's Confidential Information in confidence, shall use such Confidential Information only for the purpose of fulfilling its obligations under this Agreement, and shall use at least as great a standard of care in protecting the Confidential Information as it uses to protect its own Confidential Information.

Each Party may disclose Confidential Information only to those of its employees, agents or subcontractors who have a need to it in order to perform or exercise such Party's rights or obligations under this Agreement and who are required to protect it against unauthorized disclosure in a manner no less protective than required under this Agreement. Each Party may disclose the other Party's Confidential Information in any legal proceeding or to a governmental entity as required by Law.

These restrictions on the use or disclosure of Confidential Information do not apply to any information which is independently developed by the Receiving Party or lawfully received free of restriction from another source having the right to so furnish such information; after it has become generally available to the public without breach of this Agreement by the Receiving Party; which at the time of disclosure was already known to the Receiving Party, without restriction as evidenced by documentation in such Party's possession; or which the Disclosing Party confirms in writing is free of such restrictions.

Upon termination of this Agreement, the Receiving Party will promptly delete, destroy or, at the Disclosing Party's request, return to the Disclosing Party, all Disclosing Party's Confidential Information in its possession, including deleting or rendering unusable all electronic files and data that contain Confidential Information, and upon request will provide the Disclosing Party with certification of compliance with this subsection.

9. Data Protection

- A. **Data Privacy.** RingCentral respects Customer's privacy and will only use the information provided by Customer to RingCentral or collected in the provision of the Services in accordance with RingCentral's Data Processing Addendum, available at <https://www.ringcentral.com/legal/dpa.html>, incorporated by reference. RingCentral may update the Data Processing Addendum from time to time and will provide notice of any material updates to the Customer as required by applicable Laws at the email address on file with the Account. Such updates will be effective thirty (30) days after such notice to Customer.
- B. **Data Security.** RingCentral will take commercially reasonable precautions, including, without limitation, technical (e.g., firewalls and data encryption), organizational, administrative, and physical measures, to help safeguard Customer's Account, Account Data, and Customer Content against unauthorized use, disclosure, or modification. Customer must protect all End Points using commercially reasonable security measures. Customer is solely responsible to keep all user identifications and passwords secure. Customer must monitor use of the Services for possible unlawful or fraudulent use. Customer must notify RingCentral immediately if Customer becomes aware or has reason to believe that the Services are being used fraudulently or without authorization by any End User or third party. Failure to notify RingCentral may result in the suspension or termination of the Services and additional charges to Customer resulting from such use. RingCentral will not be liable for any charges resulting from unauthorized use of Customer's Account.
- C. **Software Changes.** RingCentral may from time-to-time push software updates and patches directly to Customer's device(s) for installation and Customer will not prevent RingCentral from doing so. Customer must implement promptly all fixes, updates,

upgrades and replacements of software and third-party software that may be provided by RingCentral. RingCentral will not be liable for inoperability of the Services or any other Services failures due to failure of Customer to timely implement the required changes.

10. Limitations of Liability

A. Excluded Damages

IN NO EVENT WILL EITHER PARTY OR ITS AFFILIATES OR ITS OR THEIR SUPPLIERS BE LIABLE FOR (1) INDIRECT, INCIDENTAL, PUNITIVE, OR CONSEQUENTIAL DAMAGES; (2) LOSS OF USE OR LOSS OF DATA; (3) LOSS OF BUSINESS OPPORTUNITIES, REVENUES OR PROFITS; OR (4) COSTS OF PROCURING REPLACEMENT PRODUCTS OR SERVICES, IN ALL CASES WHETHER ARISING UNDER CONTRACT, WARRANTY, TORT (INCLUDING NEGLIGENCE OR STRICT LIABILITY), OR ANY OTHER THEORY OF LIABILITY, AND EVEN IF SUCH PARTY HAS BEEN INFORMED IN ADVANCE OF SUCH DAMAGES OR SUCH DAMAGES COULD HAVE BEEN REASONABLY FORESEEN.

B. Liability Caps

EXCEPT AS SET FORTH HEREIN, THE TOTAL CUMULATIVE LIABILITY OF THE PARTIES UNDER THIS AGREEMENT WILL NOT EXCEED THE AMOUNTS PAID OR PAYABLE UNDER THIS AGREEMENT DURING THE PREVIOUS SIX (6) MONTHS. LIMITATIONS UNDER THIS SECTION (LIABILITY CAPS) WILL NOT APPLY TO:

- i. FEES OWED BY CUSTOMER
- ii. EITHER PARTY'S LIABILITY FOR INFRINGEMENT OF THE OTHER PARTY'S IP RIGHTS
- iii. EITHER PARTY'S LIABILITY RESULTING FROM GROSS NEGLIGENCE, FRAUD, OR WILLFUL OR CRIMINAL MISCONDUCT
- iv. CUSTOMER'S LIABILITY RESULTING FROM USE OF THE SERVICES IN BREACH OF THE ACCEPTABLE USE POLICY OR EMERGENCY SERVICES POLICY
- v. EITHER PARTY'S LIABILITY ARISING FROM DEATH OR PERSONAL INJURY CAUSED BY NEGLIGENCE, OR FOR ANY OTHER LIABILITY WHICH MAY NOT BE RESTRICTED, LIMITED, OR EXCLUDED PURSUANT TO APPLICABLE LAW.

11. Indemnification

A. Indemnification by RingCentral

- i. RingCentral shall indemnify and hold harmless the Customer and its Affiliates for Indemnifiable Amounts, and shall defend any third-party claims or causes of action (a "Third Party Claim") to the extent such Third Party Claim arises out of or alleges that:
 - a. The Services, as provided by RingCentral, infringe or misappropriate the patent, copyright, trademark, or trade secret rights of a third party.
- ii. RingCentral will have no obligations under subsection (i) above to the extent the Third Party Claim arises from: (a) use of the Services in combination with data, software, hardware, equipment, or technology not provided or authorized by RingCentral in writing unless any of the foregoing are necessary for the proper operation of the Services; (b) modifications to the Services not made by RingCentral; (c) Customer Content; (d) failure to promptly install any updates of any software or firmware or accept or use any modified or replacement items provided free of charge by or on behalf of RingCentral; (e) breach of the Agreement; or (f) a Third Party Claim brought by Customer's Affiliate, successor, or assignee.
- iii. If such a Third-Party Claim is made or appears possible, Customer agrees to permit RingCentral, at RingCentral's sole discretion and expense, to (a) modify or replace the Services, or component or part thereof, to make it non-infringing or (b) obtain the right for Customer to continue to use the Services. If RingCentral determines that neither alternative is commercially reasonable, RingCentral may terminate this Agreement in its entirety or with respect to the affected Service, component or part (a "Discontinued Component"), effective immediately on written notice to Customer, in which case Customer will not owe any fees or charges relating to the Discontinued Component for any period subsequent to the date of such termination, and will be entitled to receive a refund of any prepaid but unused fees relating to the Discontinued Component. In the event the removal of the Discontinued Component does not substantially affect Customer's use of the Services, the refund or fee abatement pursuant to the foregoing shall be a reasonable portion of the total fees owed by Customer for the Services as a whole based on the significance of the Discontinued Component to the total value of the Services as a whole. RingCentral's obligations under this Sub-Section will be RingCentral's sole and exclusive liability and Customer's sole and exclusive remedies with respect to any actual or alleged intellectual property violations.

- B. **Indemnification by Customer.** To the extent permitted by the laws and the constitution of the jurisdiction of Customer, Customer shall indemnify, and hold harmless RingCentral and its Affiliates for Indemnifiable Amounts, and shall defend any Third Party Claims arising out of or in connection with: (i) material violation of applicable Law by the Customer, its Affiliates, or their respective End Users in connection with their use of the Services; (ii) use of the Services in breach of the Use Policies; (iii) failure to promptly install any updates of any software or firmware or accept or use modified or replacement items provided free of charge by or on behalf of RingCentral; or (iv) Customer Content.

- C. **Defense and Indemnification Procedures.** Any Party seeking indemnification under this Section 11 (the “**Indemnified Party**”) shall provide the Party from which it seeks such indemnification (the “**Indemnifying Party**”) with the following: (a) prompt written notice of the Third-Party Claim, (b) sole control over the defense and settlement of the Third-Party Claim, and (c) reasonable information, cooperation, and assistance (at the Indemnifying Party’s sole expense except for the value of the time of the Indemnified Party’s personnel) in connection with the defense and settlement of the Third-Party Claim. The Indemnified Party’s failure to comply with the foregoing obligations will not relieve the Indemnifying Party of its defense or indemnification obligations under this Section 11 (Indemnification) except to the extent that the Indemnifying Party is materially prejudiced by such failure. The Indemnified Party will have the right to participate (but not control), at its own expense, in the defense of such Third-Party Claim, including any related settlement negotiations. No such claim may be settled by the Indemnifying Party without the Indemnified Party’s express written consent (not to be unreasonably withheld, conditioned, or delayed) unless such settlement includes a full and complete release of all claims and actions against the Indemnified Party by each party bringing such Third-Party Claim, requires no admission of fault, liability, or guilt by the Indemnified Party, and requires no act by the Indemnified Party other than the payment of a sum of money fully indemnified by the Indemnifying Party.

12. Warranties

- A. **RingCentral Warranty.** RingCentral will provide the Services using a commercially reasonable level of skill and care, in material compliance with all applicable Laws and otherwise subject to the terms of this Agreement. To the extent permitted by Law, RingCentral shall pass through to Customer any and all warranties RingCentral receives in connection with equipment provided to Customer by or on behalf of RingCentral.
- B. **Customer Warranty.** Customer’s and its End Users’ use of the Services must always comply with all applicable Laws and this Agreement. Further, when Customer’s subscription for Services exceeds one (1) fiscal year, Customer warrants that it shall exercise due diligence and best efforts to secure an adequate appropriation of funds on time from its legislative or similar government body to pay for the contracted Services in the follow-on fiscal year(s).
- C. **Disclaimer of Warranties.** EXCEPT AS SPECIFICALLY SET FORTH IN THIS AGREEMENT AND TO THE FULLEST EXTENT PERMITTED BY LAW, THE SERVICES ARE PROVIDED “AS IS” AND “AS AVAILABLE,” AND RINGCENTRAL MAKES NO OTHER WARRANTIES, EXPRESS OR IMPLIED, INCLUDING BUT NOT LIMITED TO THE IMPLIED WARRANTIES OF MERCHANTABILITY, NON-INFRINGEMENT, QUIET ENJOYMENT, AND FITNESS FOR A PARTICULAR PURPOSE AND ANY WARRANTIES ARISING FROM A COURSE OF DEALING OR USAGE IN TRADE, TOGETHER WITH SIMILAR WARRANTIES, WHETHER ARISING UNDER ANY LAW OR OTHERWISE. TO THE EXTENT THAT RINGCENTRAL CANNOT DISCLAIM ANY SUCH WARRANTY AS A MATTER OF APPLICABLE LAW, THE SCOPE AND DURATION OF SUCH WILL BE LIMITED TO THE FULLEST EXTENT PERMITTED BY LAW.

13. Dispute Resolution

- A. **Governing Law.** Any dispute arising out of or relating to this Agreement shall be governed and construed in accordance with the laws of TX, without regard to its choice of law rules, and the parties agree to submit to the jurisdiction of, and venue in, the courts in Austin County, TX. The United Nations Convention on Contracts for the International Sale of Goods does not apply to this Agreement or Customer’s use of the products or Services.
- B. **Good Faith Attempt to Settle Disputes.** In the event of a dispute, each Party shall appoint a duly authorized representative who shall use all reasonable endeavors to resolve in good faith any dispute within reasonable timescales.
- C. **Equitable Relief.** Any breach of either Party’s IP Rights may cause that Party irreparable harm for which monetary damages will be inadequate and such Party may, in addition to other remedies available at Law or in equity, obtain injunctive relief without the necessity of posting a bond or other security, proof of damages, or similar requirement, in addition to any other relief to which such Party may be entitled under applicable Law.
- D. **Limitations.** Except for actions for non-payment or liability arising from Section 11 (Indemnification), no claim, suit, action or proceeding relating to this Agreement may be brought by either Party more than two (2) years after the cause of action has accrued. Any actions, lawsuits, or proceedings must be conducted solely on an individual basis and the Parties expressly waive any right to bring any action, lawsuit or proceeding as a class or collective action, private attorney general action or in any other capacity acting in a representative capacity.

14. Miscellaneous

- A. Relationship of the Parties.** RingCentral and Customer are independent contractors, and this Agreement will not establish any relationship of partnership, joint venture, employment, franchise or agency between RingCentral and Customer.
- B. Assignment.** Neither Party may assign its rights or obligations under this Agreement or any Order Form without the prior written consent of the other Party, not to be unreasonably withheld or delayed. However, RingCentral may assign the Agreement or any portion thereof and any or all of its rights and obligations thereunder without consent (a) to an Affiliate; (b) as part of, or otherwise in connection with, the transfer or disposition of equity securities representing more than fifty percent (50%) of its voting control; (c) to the successor or surviving entity in connection with a merger, acquisition, or consolidation; or (d) as part of, or otherwise in connection with, the sale or other transfer of one or more of the service(s) under the Agreement or greater than 50% of the principal assets used in connection with the provision such service(s). This Agreement will bind and inure to the benefit of the Parties, and their permitted assigns and successors.
- C. Notices.** Except where otherwise expressly stated in the Agreement, all notices or other communications must be in English and are deemed to have been fully given when made in writing and delivered in person, upon delivered email, confirmed facsimile, or five days after deposit with a reputable overnight courier service, and addressed as follows: To RingCentral at RingCentral, Inc., Legal Dept., 20 Davis Drive, Belmont, CA 94002 USA, with a copy to legal@ringcentral.com, and to Customer at either the physical address or email address associated with the Customer Account.

Customer acknowledges and agrees that all electronic notices have the full force and effect of paper notices. The addresses to which notices may be given by either Party may be changed (a) by RingCentral upon written notice given to Customer pursuant to this Section or (b) by Customer in the Administrative Portal.

- D. Force Majeure.** Excluding either Party's payment obligations under the Agreement, neither Party will be responsible or liable for any failure to perform or delay in performing to the extent resulting from any event or circumstance that is beyond that Party's reasonable control, including without limitation any act of God; national emergency; third-party telecommunications networks; riot; war; terrorism; governmental act or direction; change in Laws; fiber, cable, or wire cut; power outage or reduction; rebellion; revolution; insurrection; earthquake; storm; hurricane; flood, fire, or other natural disaster; strike or labor disturbance; or other cause, whether similar or dissimilar to the foregoing, not resulting from the actions or inactions of such Party.
- E. Third-Party Beneficiaries.** RingCentral and Customer agree that there will be no third-party beneficiaries to this Agreement.
- F. Headings, Interpretation.** The headings, section titles, and captions used in the Agreement are for convenience of reference only and will have no legal effect. All defined terms include related grammatical forms, and, whenever the context may require, the singular form of nouns and pronouns include the plural, and vice versa. The Parties agree that this Agreement will be deemed to have been jointly and equally drafted by them, and that the provisions of this Agreement therefore should not be construed against a Party or Parties on the grounds that the Party or Parties drafted or was more responsible for drafting the provision(s).
- G. Anti-Bribery.** Each Party represents that in the execution of this Agreement and in the performance of its obligations under this Agreement it has complied and will comply with all applicable anti-bribery Laws and regulations, including, without limitation, the U.S. Foreign Corrupt Practices Act, the UK Bribery Act, and similar applicable Laws.
- H. Export Control.** Any services, products, software, and technical information (including, but not limited to, services and training) provided pursuant to the Agreement may be subject to U.S. export Laws and regulations. Customer will not use, distribute, transfer, or transmit the services, products, software, or technical information (even if incorporated into other products) except in compliance with U.S. and other applicable export regulations.
- I. Regulatory and Legal Changes.** In the event of any change in Law, regulation or industry change that would prohibit or otherwise materially interfere with RingCentral's ability to provide Services under this Agreement, RingCentral may terminate the affected Services or this Agreement or otherwise modify the terms thereof.
- J. Use of Beta, Preview, or Early Access Software.** If you use any beta, preview, or early access services, features, products, or software offered or made available by RingCentral, then you acknowledge that your use of the services, products, or software are governed by the [Beta Evaluation License Agreement](#) and not by this Agreement.
- K. Entire Agreement.** The Agreement, together with any exhibits, Order Forms, Use Policies, and Attachments, each of which is expressly incorporated into this Agreement with this reference, constitutes the entire agreement between the Parties and supersedes and replaces any and all prior or contemporaneous understandings, proposals, representations, marketing materials, statements, or agreements, whether oral, written, or otherwise, regarding such subject. RingCentral expressly rejects in their entirety any additional or conflicting terms or conditions contained in Customer purchase order, or similar Customer document, which the Parties agree are solely for the Customer's convenience.
- L. Order of Precedence.** In the event of any conflict between the documents comprising this Agreement, precedence will be given to the documents in the following descending order: (i) the applicable Order Form (including any hyperlinks); (ii) the applicable Attachment; (iii) the main body of this Agreement; (iv) Use Policies and Data Processing Addendum incorporated by reference in this Agreement; and (v) any other document expressly referred to in this Agreement which governs the Services. With respect to data processing, the Data Processing Addendum shall take precedence over any inconsistent terms in any of the documents listed in the previous sentence.
- M. Amendments.** Except as otherwise provided, this Agreement may only be modified by a written amendment executed by authorized representatives of both Parties. In no event will handwritten changes to any terms or conditions, including in the applicable Order Form, be effective.

- N. Severability and Waiver.** In the event any provision of this Agreement is held by a court of competent jurisdiction to be invalid, void or unenforceable, such provision(s) will be stricken and the remainder of this Agreement will remain legal, valid, and binding. The failure by either Party to exercise or enforce any right conferred by this Agreement will not be deemed to be a waiver of any such right or to operate so as to bar the exercise or enforcement of any such or other right on any later occasion. Except as otherwise expressly stated in this Agreement, all rights and remedies stated in the Agreement are cumulative and in addition to any other rights and remedies available under the Agreement, at Law, or in equity.
- O. Execution.** Each Party represents and warrants that: (a) it possesses the legal right and capacity to enter into the Agreement and to perform all of its obligations thereunder; (b) the individual signing the Agreement and (each executable part thereof) on that Party's behalf has full power and authority to execute and deliver the same; and (c) the Agreement will be a binding obligation of that Party. Each Party agrees that an Electronic Signature, whether digital or encrypted, is intended to authenticate this Agreement and to have the same force and effect as manual signatures.
- P. Counterparts.** This Agreement may be executed electronically and in separate counterparts each of which when taken together will constitute one in the same original.
- Q. Survival.** The rights and obligations of either Party that by their nature would continue beyond the expiration or termination of this Agreement or an Order Form will survive expiration or termination of this Agreement or the Order Form, including without limitation payment obligations, warranty disclaimers, indemnities, limitations of liability, definitions and miscellaneous.
- R. Family Education Rights and Privacy Act (FERPA).** Customer Content when in-transit on the RingCentral Network and when at-rest within RingCentral Data Centers may contain communications and/or educational records pertaining to students in connection with the performance of the Services pursuant to the Agreement. RingCentral shall only use or disclose such Customer Content as is reasonably necessary to provide the Services or for RingCentral to otherwise perform its obligations under the Agreement.

EXHIBIT A DEFINITIONS

Definitions. Capitalized terms used in this Agreement but otherwise not defined have the following meaning:

1. **"Account"** means the numbered account established with RingCentral and associated with Customer and the Services provided to Customer under this Agreement. For billing and convenience purposes, multiple services, Digital Lines, or End Users may be included in a single billing account, and/or a single Customer may have multiple billing accounts encompassing different geographic locations, business units, or other designations as requested by Customer and accepted by RingCentral.
2. **"Account Administrator"** means the person(s) who have been granted authority by Customer to set up, amend, or otherwise control settings and/or make additional purchases for the Account via the Administrative Portal. Account Administrators may have varying levels of Account rights, skills, or permissions.
3. **"Account Data"** means: any business contact information provided with the Account; RingCentral-generated logs of calling or other metadata developed or collected in the provision of the Services; configuration data; and records of Digital Lines and any Services purchased under this Agreement.
4. **"Administrative Fees"** means any administrative recovery fees, 911 cost recovery fees and the like separately charged by RingCentral to Customer.
5. **"Administrative Portal"** means the online administrative portal through which Account Administrators control settings and/or make additional purchases for the Account.
6. **"Affiliate(s)"** means a person or entity that is controlled by a Party hereto, controls a Party hereto, or is under common control with a Party hereto, and "control" means beneficial ownership of greater than fifty percent (50%) of an entity's then-outstanding voting securities or ownership interests.
7. **"Attachment(s)"** means documents appended to the contract containing additional terms for products and Services. Attachments and the terms and conditions contained therein are part of this Agreement.
8. **"Confidential Information"** means any information disclosed by or on behalf of the Disclosing Party) to the Receiving Party that should reasonably be considered as confidential given the nature of the information and the circumstances surrounding its disclosure.
9. **"Customer Care"** means Customer support operations delivered by RingCentral and/or its subcontractors.
10. **"Customer Content"** means the content of calls, facsimiles, SMS messages, voicemails, voice recordings, shared files, conferences, or other communications transmitted or stored through the Services.
11. **"Digital Line"** means a phone number assigned to an End User or a specifically designated location (e.g., conference room) and the associated voice service for inbound and outbound calling that permits an End User generally to make and receive calls to and from the public switched telephone network as well as to and from other extensions within the same Account.
12. **"Disclosing Party"** means the Party disclosing Confidential Information or on whose behalf Confidential Information is disclosed by such Party's agents, including but not limited to, its Affiliates, officers, directors, employees, and attorneys.
13. **"Electronic Signatures"** means an electronic sound, symbol, or process, including clicking a digital button to accept, attached to or logically associated with a contract or other record and executed or adopted by a person with the intent to sign the record.
14. **"End Point"** means an application or device through which any End-User might access and/or use any of the Services, including without limitation IP Desk Phones, Desktop Clients, Web Clients, Mobile Applications, and Software Integrations.
15. **"End User"** means an individual user to whom Customer makes the Services available, and may be a natural person, and may include but is not limited to Customer's employees, consultants, clients, external users, invitees, contractors, and agents.
16. **"Helpdesk Support"** shall mean the performance of the following tasks:
 - Standard feature/functionality ("how to") support for End Users (i.e. call forwarding, voice mail set-up, etc.).
 - Standard management of the Admin Interface within the product.
 - Support all moves, adds, changes, and deletes of employees.
17. **"Indemnifiable Amounts"** means all (X) damages and other amounts awarded against the Indemnified Party by a court of competent jurisdiction pursuant to a final judgment in connection with such Third-Party Claim; (Y) any amounts payable by the Indemnified Party or its Affiliates pursuant to a binding, written agreement settling the Third Party Claim, provided such agreement is approved in advance in writing by the Indemnifying Party; and (Z) all reasonable costs and expenses paid to third parties by the Indemnified Party or its Affiliates in connection with the Indemnified Party's or its Affiliates' attorneys' fees and related expenses.
18. **"Indemnifying Party"** and **"Indemnified Party"** have the meanings set forth in Section 11(C) (Defense and Indemnification Procedures).
19. **"Initial Term"** has the meaning set forth in Section 2(D) (Services Term).

20. **"Intellectual Property Rights" or "IP Rights"** means all common law and statutory rights (whether registered or unregistered, or recorded or unrecorded, regardless of method) arising out of or associated with: (a) patents and patent applications, inventions, industrial designs, discoveries, business methods, and processes; (b) copyrights and copyright registrations, and "moral" rights; (c) the protection of trade and industrial secrets and Confidential Information; (d) other proprietary rights relating to intangible property; (e) trademarks, trade names and service marks; (f) a person's name, likeness, voice, photograph or signature, including without limitation rights of personality, privacy, and publicity; (g) analogous rights to those set forth above; and (h) divisions, continuations, continuations-in-part, renewals, reissuances and extensions of the foregoing (as applicable).
21. **"Law"** means any law, statute, regulation, rule, ordinance, administrative guidance, treaty or convention, or court or administrative order or ruling of any governing Federal, State, local or non-U.S. governmental body with jurisdiction over the Services.
22. **"Order Form(s)"** means a request for Service describing the type and quantity of Services required by Customer and submitted and accepted by the Parties in accordance with Section 2(A) (Ordering Services). The Order Form may be presented and executed via the Administrative Portal.
23. **"Receiving Party"** means the Party or its agents, including, but not limited to its Affiliates, officers, directors, employees, and attorneys receiving Confidential Information.
24. **"Renewal Term"** has the meaning set forth in Section 2(D) (Services Term).
25. **"RingCentral Network"** means the network and supporting facilities between and among the RingCentral points of presence ("PoP(s)"), up to and including the interconnection point between the RingCentral's network and facilities, and the public Internet, and the Public Switched Telephone Network (PSTN). The RingCentral Network does not include the public Internet, a Customer's own private network, or the PSTN.
26. **"Service(s)"** means all services provided under this Agreement and set forth in one or more Order Form(s).
27. **"Start Date"** means the date so identified in the relevant Order Form or the date on which Customer orders Services via the Administrative Portal.
28. **"Taxes"** means any and all federal, state, local, municipal, foreign, and other taxes and fees charged or collected from Customers, including but not limited to any Universal Service Fund, TRS and 911 taxes and fees.
29. **"Term"** means the Initial Term plus any Renewal Terms.
30. **"Third Party Claim"** has the meaning set forth in Section 11(A) (Indemnification by RingCentral).
31. **"Use Policy"** refers to any of the policies identified in Section 5(B) (Use Policies).

ATTACHMENT A
SERVICE ATTACHMENT - RINGEX SERVICES

This Service Attachment is a part of the Master Services Agreement (the “**Agreement**”) that includes the terms and conditions agreed by the Parties under which RingCentral will provide to the Customer the RingEX Services as described under the applicable Order Form (the “**Services**”).

1. Service Overview

The Services are a cloud-based unified communications service that includes enterprise-class voice, fax, call handling, mobile apps, and bring-your-own-device (BYOD) capability that integrates with a growing list of applications.

The Services include:

- Voice Services, including extension-to-extension calling and the ability to make and receive calls to and from the public switched telephone network (PSTN)
- Video and audio-conferencing service, including screen sharing
- Collaboration Tools, including One-to-One and Team Chat, File Sharing, task management, SMS/Texting (where available), and other innovative tools

The Services may be accessed from a variety of user End Points, including IP Desk Phones, Desktop Clients, Web Clients, Mobile Applications, and Software Integrations.

2. RingEX Purchase Plans

A. Tiers of Service. The Services are made available in several pricing tiers, which are described more fully at <https://www.ringcentral.com/office/plansandpricing.html>. While RingCentral offers unlimited monthly plans for some of its products and services, RingCentral Services are intended for regular business use. “Unlimited” use does not permit any use otherwise prohibited by the Acceptable Use Policy, available at <https://www.ringcentral.com/legal/acceptable-use-policy.html>, including trunking, access stimulation, reselling of the Services, etc. Use of the RingCentral AI Assistant capabilities is subject to the applicable terms contained in the AI Assistant Add-On Service Description available at <https://www.ringcentral.com/legal/add-on-services.html#qlnks-12>.

B. Minute and Calling Credit Bundles. Each plan includes a number of Toll-Free minutes, per month, which are pooled to create a single allotment of Toll-Free minutes available for the entire account. Core/Advanced/Ultra tier plans include a monthly allotment of 100/1000/10000 toll free minutes per account, respectively. Overage charges of 3.9¢ per minute apply to calls made in excess of allotment.

International Calling Credit Bundles can be purchased in addition to any base amount included with the purchased tier. International External Calls are charged against Calling Credits on the Account per destination rates, or as overage once Calling Credits are exceeded. Currently effective rates are available at <https://www.ringcentral.com/support/international-rates.html>.

Extension-to-Extension Calls within the Customer account never incur any usage fee and are unlimited, except to the extent that such calls are forwarded to another number that is not on the Customer account.

Additional Calling Credits may be purchased through the Auto-Purchase feature, which can be selected for automatic purchase in various increments on the Administrative Portal. Auto-Purchase is triggered when the combined usage of all End Users on an Account exceeds the total Calling Credits or when End Users make calls with additional fees (e.g., 411).

Minute Bundles and Calling Credit Bundles expire at the end of month and cannot roll over to the following month. Auto-Purchased Calling Credits expire twelve (12) months from date of purchase. Bundles may not be sold, transferred, assigned, or applied to any other customer.

C. Enhanced Business SMS Allotment and Pricing. Each plan includes a number of SMS per each user, per month, which are pooled to create a single allotment of SMS available to the entire account. Core/Advanced/Ultra tier plans include a monthly allotment of 25/100/200 SMS, per user respectively. Each SMS sent or received will be deducted from the pool of available SMS on the account. Overage charges apply to SMS sent or receive in excess of allotment and will be charged at the then-applicable rates, available at <https://www.ringcentral.com/support/new-sms-rates.html>. Additional SMS bundles are available for purchase at discounted prices. Customer must successfully register phone numbers with the SMS registrar prior to using SMS. RingCentral may attempt to deliver SMS sent from unregistered phone numbers at its discretion, however unregistered SMS are excluded from the monthly allotment and any purchased SMS bundles, and will be charged at then-applicable unregistered SMS rates, available at <https://www.ringcentral.com/support/new-sms-rates.html>.

3. Operator Assisted Calling, 311, 511 and other N11 Calling

RingCentral does not support 0+ or operator assisted calling (including, without limitation, collect calls, third party billing calls, 900, or other premium line numbers or calling card calls). The Services may not support 211, 311, 411, 511 and/or N11 calling. To the extent they are supported, additional charges may apply for these calls.

4. Directory Listing Service

RingCentral offers directory listing (the “**Directory Listing Service**”). If Customer subscribes to the Directory Listing Service, RingCentral will share certain Customer Contact Data with third parties as reasonably necessary to include in the phone directory (“**Listing Information**”). This information may include, but is not limited to, Customer’s company name, address, and phone numbers. Customer authorizes RingCentral to use and disclose the Listing Information for the purpose of publishing in, and making publicly available through, third-party directory listing services, to be selected by RingCentral or third-party service providers in their sole discretion. Customer acknowledges and agrees that by subscribing to the Directory Listing Service, Customer’s Listing Information may enter the public domain and that RingCentral cannot control third parties’ use of such information obtained through the Directory Listing Service.

A. Opt Out. Customer may opt out of the Directory Listing Service at any time; however, RingCentral is not obligated to have Customer’s Listing Information removed from third-party directory assistance listing services that have already received Customer’s information.

B. No Liability. RingCentral will have no responsibility or liability for any cost, damages, liabilities, or inconvenience caused by calls made to Customer’s telephone number; materials sent to Customer, inaccuracies, errors or omissions with Listing Information; or any other use of such information. RingCentral will not be liable to Customer for any use by third parties of Customer’s Listing Information obtained through the Directory Listing Service, including without limitation the use of such information after Customer has opted out of the Directory Listing Service.

5. Global RingEX or RingCentral Global Office. Global RingEX (which is also known as RingCentral Global Office and references in the Service Description to Global RingEX shall also refer to Global Office) provides a single communications system to companies that have offices around the world, offering localized service in countries for which Global RingEX is available. Additional information related to Global RingEX Services is available at <http://www.ringcentral.com/legal/policies/global-office-countries.html>. This section sets forth additional terms and conditions concerning RingCentral’s Global RingEX for customers that subscribe to it.

A. Emergency Service Limitations for Global RingEX. RingCentral provides access to Emergency Calling Services in many, but not all, countries in which RingCentral Global RingEX is available, allowing End Users in most countries to access Emergency Services. Emergency Services may only be accessed within the country in which the Digital Line is assigned, e.g., an End User with a Digital Line assigned in Ireland may dial Emergency Services only within Ireland. Access to Emergency Calling Services in RingCentral Global RingEX countries, where available, is subject to the Emergency Services Policy, available at <https://www.ringcentral.com/legal/emergency-services.html>. Customer must make available and will maintain at all times traditional landline and/or mobile network telephone services that will enable End Users to call the applicable Emergency Services number. Customer may not use the RingCentral Services in environments requiring fail-safe performance or in which the failure of the RingCentral Services could lead directly to death, personal injury, or severe physical or environmental damage.

B. Global RingEX Provided Only in Connection with Home Country Service. RingCentral provides Global RingEX Service only in connection with Services purchased in the Home Country. RingCentral may immediately suspend or terminate Customer’s Global RingEX Services if Customer terminates its Digital Lines in the Home Country. All invoicing for the Global RingEX Services will be done in the Home Country on the Customer’s Account, together with other Services purchased under this Agreement, using the Home Country’s currency. Customer must at all times provide a billing address located in the Home Country. RingCentral will provide all documentation, licenses, and services in connection with the Global RingEX Service in English; additional language support may be provided at RingCentral’s sole discretion.

C. Primary Place of Use of Global RingEX Service. Customer represents and warrants that the primary place of use of the Global RingEX Services will be the country in which the Digital Line is assigned, e.g., an End User with a Digital Line assigned in Ireland will primarily use that Digital Line in Ireland.

D. Relationships with Local Providers. In connection with the provision of Global RingEX Services, RingCentral relies on local providers to supply certain regulated communication services; for example (i) for the provision of local telephone numbers within local jurisdictions; (ii) to enable you to place local calls within local jurisdictions; and (iii) to enable you to receive calls from non-RingCentral numbers on Customer’s Global RingEX telephone number(s), by connecting with the local public switched telephone network. Customer hereby appoints RingCentral as Customer’s agent with power of attorney (and such appointment is coupled with an interest and is irrevocable during the Term) to conclude and enter into agreements with such local providers on Customer’s behalf to secure such services. RingCentral’s locally licensed affiliates provide all telecommunications services offered to Customer within the countries in which such affiliates are licensed; in some cases, RingCentral may obtain services from locally licensed providers on Customer’s behalf. RingCentral is responsible for all contracting, billing, and customer care related to those services. Customer is responsible for providing RingCentral with all information necessary for RingCentral to obtain numbers in Global RingEX countries.

6. **Additional Services.** RingCentral offers add-on services for the Services (where available), which are described at <https://www.ringcentral.com/legal/microsoft-teams-services-attachment.html>. Additional terms or charges may apply, depending on the selected features.
7. **Bring Your Own Carrier (BYOC) Services.** RingCentral offers a software-as-a-service in which customers provide and maintain their own local telecommunications services, which may be connected to RingCentral's cloud PBX, videoconferencing, and team messaging services. BYOC and additional terms are described and available at <https://www.ringcentral.com/legal/BYOC-service-description.html>.
8. **Definitions.** Terms used herein but not otherwise defined have the meanings ascribed to them in the Agreement. For purposes of this Service Attachment, the following terms have the meanings set forth below:
 - A. **“Digital Line”** means a phone number assigned to an End User or a specifically designated location (e.g., conference room) and the associated voice service for inbound and outbound calling that permits the End User generally to make and receive calls to and from the public switched telephone network as well as to and from other extensions within the same Account.
 - B. **“End Point”** means an application or device through which any End-User might access and/or use any of the Services, including without limitation IP Desk Phones, Desktop Clients, Web Clients, Mobile Applications, and Software Integrations.
 - C. **“Extension-to-Extension Calls”** means calls made and received between End Points on the Customer Account with RingCentral, regardless of whether the calls are domestic or international.
 - D. **“External Calls”** means calls made to or received from external numbers on the PSTN that are not on the Customer Account with RingCentral.
 - E. **“Home Country”** means the United States or the country that is otherwise designated as Customer's primary or home country in the Order Form.

Verizon One Talk Quote

(References Texas DIR contract on page 3)

(Florida Terms & Conditions still apply to
installation & training services)

Masters Telecom LLC
1225 NW 17th Ave Ste 101
Delray Beach, FL 33445
United States

Quote #	25561 v7
Date	Feb 27, 2026
Expires	Mar 27, 2026
Contact	Chad Mendelsohn

Prepared for Sealy Police Department
Russell Grimes
415 Main St
Sealy, TX 77474
United States

T: 9798853511
E: rgrimes@ci.sealy.tx.us

ACCEPT QUOTE

Government- One Talk & Masters Telecom Services



Verizon Services

Monthly Fees

Item	Quantity	Amount	Total
One Talk Standard - Desk Phone -Government	53	\$25.00	\$1,325.00
Auto Receptionist	1	\$20.00	\$20.00
Hunt Group	10	\$0.00	\$0.00
Tier 2 Desk Phone Discount (50-199 lines)	53	(\$5.00)	(\$265.00)
Total Monthly			\$1,080.00 USD

One-Time Fees

Item	Quantity	Amount	Total
Yealink T74LTE Desk Phone (GOV)	50	\$219.00	\$10,950.00
Highlights			\$0.00
• Linux 6.1 OS			
• 4.3-inch (480x272) resolution screen			
• VoLTE calling			
• Built-in eSIM			
• VoLTE calling			
• Optimal HD audio, smart noise filtering			
• Built-in Bluetooth 5, supports Bluetooth headset			
• Built-in dual band 2.4G/5G Wi-Fi			
• Battery: 6300mAh, rechargeable lithium-ion			
• Battery: 3.7V, 11.47Wh			
100% Item Discount (\$10,950.00)			

Item	Quantity	Amount	Total
 <p>W78B - Cordless Base Station (GOV)</p>	3	\$103.20	\$309.60
 <p>W59VR- Add on Rugged Cordless handset for the W78B</p> <p>Yealink Ruggedized DECT Handset</p> <p>Yealink W59R, certified to rigorous IP67 standard, is a professional ruggedized DECT handset with integrated Bluetooth and vibration alarm</p>	3	\$179.00	\$537.00
 <p>Verizon Bill Incentive Credits</p> <ul style="list-style-type: none"> All incentive credits will show on the 2nd or 3rd bill after activation Requires activation of new desk phone with One Talk Service \$50.00 credit per a new line of service activated on a desk phone 	3	(\$50.00)	(\$150.00)
<p>Verizon Bill Incentive Credits- LTE Phones</p> <ul style="list-style-type: none"> All incentive credits will show on the 2nd or 3rd bill after activation Requires activation of new desk phone with One Talk Service \$100.00 credit per a new line of service activated on a desk phone 	50	(\$100.00)	(\$5,000.00)
<p>Professional Onsite Installation (One Talk) -GOV</p> <p>Free installation with 8 or more one talk phones.</p>	2	\$1,300.00	\$2,600.00 \$0.00
100% Item Discount (\$2,600.00)			

Please contact us if you have any questions.

One-Time Subtotal	\$9,246.60
Discount	(\$13,550.00)
Total One-Time	(\$4,303.40) USD

ACCEPT QUOTE

Cost Breakdown

Category	One-Time Fees	Monthly Fees
Verizon Monthly	—	\$1,080.00
Verizon Device	\$11,796.60	—
Verizon One Time / Verizon	(\$5,150.00)	—
Specialty Services	\$2,600.00	—
Discount	(\$13,550.00)	—
Total	(\$4,303.40) USD	\$1,080.00 USD

Comments

All One Talk services are sold and billed from Cellco Partnersjip DBA Verizon Wireless on the Texas DIR contract the contract can be viewed here --><https://dir.texas.gov/contracts/dir-tele-ctsa-003>

Vendor ID: 1223372889300
 RFO: DIR-CPO-TMP-552
 Contract Status: Active

Executive Summary

Masters Telecom LLC was founded in 2008 and has been a member of the Verizon Partner Program for over 17 years. We operate nationwide in all customer segments including Corporate/Enterprise, Small & Medium Business, & Government. Our team specializes in the sales deployment, and support of the Verizon One Talk service with well over 35,000 One Talk Phone installations in the past year. Our commitment to supporting Verizon and their customers has made us one the most trusted Verizon Value Added Resources.

Professional Installation & Training

Masters Telecom will provide at no additional cost to the customer:

- Digital whiteboarding and call flow mapping.
- Automated Network Bandwidth and Analysis software
- Dedicated project manager
- Training & Support documentation will be provided to every user.
- Training Cards which can be customized based on customer's needs.
- PowerPoint and Video training material will also be provided.
- One Talk portal configuration, training & ongoing portal support.
- Unlimited lifetime Remote support for One Talk services.

Masters Telecom will also provide onsite professional installation*

Onsite installation of One Talk Phones.

- Connect all phones to LAN via Ethernet or WIFI
- Confirm that all devices working correctly.
- Perform test call for E-911 verification.

Remote training

- Desk phone/App training
- Voicemail & Speed Dials setup
- Administrator training for Verizon Mybusiness portal

*Free installation based on purchase of 8 desk phones activated with monthly service plan.

Does not include all applicable local, state, and federal taxes on the transaction described in the quote. Prices are subject to change.

No tax exemption may be recognized unless a valid certificate of tax exemption is provided.

Early Termination fee of \$175.00 may apply

[Professional Services and Equipment Terms and Conditions - Masters](#)

Click link for full list of Terms & Conditions: [Telecom](#)

ITEM #3

ITEM #4



AGENDA ITEM NO: 4 Discussion and Possible Action regarding Texas Historical Commission Designation Review and Authorization to Bid for Liedertafel Hall Project.

SUBMITTED BY: Sealy EDC Staff

MEETING DATE: March 3, 2026

STAFF REPORT

DESCRIPTION

At the December 2, 2025, meeting M-6 Studios presented the completed a review, documentation, and ADA compliance modeling for the Liedertafel Hall. Design elements were presented for Council direction including

- ADA-compliant restrooms configuration, entrance approaches,
- Preferred kitchen layout,
- Storage addition,
- Preferred historic-appropriate finishes

Staff came back to the Council on December 16th to discuss the historical marker status, phasing and budgeting for the improvements. Discussion was held regarding the impact on timing, funding and the cost benefit of such pursuits. A motion was then made to table this item in order for staff to research the design and speak to the Texas Historical Commission on possible options and implications regarding historical designations.

Tonight, staff is back to provide the following information previously requested from various items brought forward by council during past discussions.

- First, advise Council on the information they last requested regarding increase time and costs associated with change in historic designation and arrive a decision on this.
- Second, the phases presented by the architect and costs are subject increase with time, so to be safe we have added a 5% escalation for potential product price increases. We also have included a 15% contingency. This will provide for a conservative estimate and help mitigate potential short-falls.
- Third, staff will create the necessary budget amendment(s) for funding the chosen project scope and present this to the Sealy EDC Board in March and then to City Council in April.
- Staff will then bid both phases of construction.
- These decisions provide the information to staff to properly create a timeline, budget, funding sources, steps and actions and insure bid documents cover the project and are done in accordance with governing processes.

ANALYSIS

To address the historic landmark designation, staff spoke with the Texas Historic Commission, they researched the property and have found and confirmed that the Liedertafel Hall presently has a Historical Subject Marker (HSM) but has not found any evidence that the property is a Recorded Texas Historic Landmark (RTHL) or a State Antiquities Landmark (SAL).

If the designations of RTHL or a SAL were pursued, both of these state designations give the THC review authority over proposed alterations to the structure.

- For a building with an RTHL designation, no individual may alter the historical or architectural integrity of a building's exterior without first providing the commission written notice at least 60 days prior to initiating the proposed changes.
- All THC reviews are to be completed in no greater than 30 days from the date the THC receives the project documentation, and often once the review is completed, the 60-day waiting period is waived.
- The THC reviews proposed changes to RTHL buildings and structures by applying the Secretary of the Interior's Standards for the Treatment of Historic Properties.

THC advised that due to alterations made over time to the Liedertafel Hall and property, pursuing THC designation would require extensive documentation, potential architectural modifications to meet stricter integrity standards, expanded review processes as well as time and may incur significant financial investment.

Based on this information, staff recommends maintaining the current HSM designation. This approach provides regulatory clarity prior to procurement and avoids introducing additional cost and schedule risk at a critical stage of the project.

Maintaining the current Historical Subject Marker status allows the City to proceed within established regulatory parameters while protecting fiscal and scheduling flexibility.

FINANCIAL IMPACTS

The SEDC held a public hearings on December 15, 2025, to amend the EDC Budget regarding the Liedertafel Hall Budget and expenditure of funds for the Phase II Liedertafel Improvements. The SEDC was advised these items will be brought back to them following the action by the City Council.

Phase II of the Liedertafel Hall improvements has been identified as a necessary continuation of the facility rehabilitation program in this fiscal year. Supporting documents show a Phase II cost of \$153,826, with a budget amendment of \$155,000 to fund the improvements.

Phase I Funding Requirements

Phase I was budgeted at \$79,302 and is fully funded through HOT Category E and EDC Capital Outlay. The HOT-funded portion will be fully expended first, while EDC Capital Outlay will retain a carry-over balance available for allocation to Phase II. Phase I improvements cost estimate by the architect is in the attached.

Description	Phase I Budgeted Costs	Funding Sources	Use of Funds	Carry Over to Phase II
Phase I Total Costs: Liedertafel Phase I	\$79,032			
Phase I Contingency 15%: Liedertafel Phase I	\$11,895			
Total Phase I Costs: Liedertafel Phase I	\$90,972			
56020 – HOT (Category E) Building Improvements		\$35,475	(\$35,475)	\$0
56010 – EDC Building Improvements		\$75,000	(\$55,452)	\$19,548
Phase I Total	\$90,972	\$110,475	(\$90,927)	\$19,548

Phase II Funding Requirements

The originally adopted budget did not contemplate Phase II for the Liedertafel Hall. The cost of Phase II is estimated by the architect at a cost of \$153,556 above current allocations for this fiscal year of \$110,475 for a total amended budget of \$264,031. Phase II scope includes the restoration of exterior shutters and the addition of masonry skirting, with improvements to the interior and exterior, including structural, mechanical, electrical, and accessibility. The detailed cost estimate for Phase II is attached.

Description	Phase II Budgeted Costs	Carry Over from Phase I	Requested Budget Amendment
56010-EDC Liedertafel Phase II	\$115,526		
56010-EDC Add: Shutters & Masonry Skirting	\$35,000		
56010-Phase II Contingency 15%	\$22,578		
TOTAL COST OF PHASE II	\$173,104		
Carry-Over from Phase I		(\$19,548)	
Actual Budget Amendment			\$153,556

ATTACHMENTS

- 2 - Memo Sealy Economic Development Corporation Projects Status and Updates February 13, 2026
- 3 - Pricing 2025 Phase 1
- 4 - Pricing 2025 Phase 2
- 5 - Updated Liedertafel Project Budget Details Spreadsheet
- 6 - Liedertafel Hall Combined Drawings

RECOMMENDATION

Staff's recommendation is for the City Council to maintain the historical marker status for the Liedertafel Hall and for staff to take all actions necessary to amend the Liedertafel Hall Budget, create all necessary bid documents and bid the project accordingly.

M6 Builders

m6builders.com - 832.876.7113

scottm@studio-m6.com

Construction Costs
Liedertafel Phase I
11.18.25

CLIENT: Bill Atkinson, Sealy EDC
ADDRESS: 116 Lux Rd, Sealy, TX 77474

DESCRIPTION	VENDOR	UNITS	UNIT \$	CONTRACT \$
01 GENERAL CONDITIONS				
SUPERVISION		4	\$ 1,500.00	\$ 6,000.00
TEMPORARY TOILET		2	\$ 275.00	\$ 550.00
PLAN REPRODUCTION		1	\$ 250.00	\$ 250.00
TEMPORARY PROTECTION		1	\$ 250.00	\$ 250.00
PRESSURE WASHING - ROOF, EXT WALLS AND EAVES		1	\$ 2,900.00	\$ 2,900.00
TRASH HAUL		1	\$ 800.00	\$ 800.00
DAILY/FINAL CONSTRUCTION CLEANUP		1	\$ 500.00	\$ 500.00
02 DEMOLITION				
INTERIOR DEMOLITION		1	\$ 900.00	\$ 900.00
05 STEEL				
STEEL HANDRAILS		1	\$ 5,250.00	\$ 5,250.00
06 CARPENTRY				
FILL IN STAIRS AT SIDE EXIT/BUILD NEW EXT STAIRS		1	\$ 4,500.00	\$ 4,500.00
FRONT DOOR LABOR		1	\$ 2,500.00	\$ 2,500.00
MOVE 2 WALLS AND RESTROOM WORK		1	\$ 3,950.00	\$ 3,950.00
08 DOORS, WINDOWS AND GLASS				
DOORS/FRAMES AND HARDWARE		1	\$ 3,500.00	\$ 3,500.00
09 FINISHES				
REPAIR WOOD FLOOR AS NEEDED		1	\$ 1,850.00	\$ 1,850.00
BANISTER LABOR - FRONT PORCH AND RAMP		1	\$ 3,800.00	\$ 3,800.00
BANISTER MATERIAL - ALLOWANCE		1	\$ 7,500.00	\$ 7,500.00
PAVER LABOR - FRONT PORCH AND RAMP		1	\$ 4,350.00	\$ 4,350.00
PAVER MATERIAL - ALLOWANCE		1	\$ 5,500.00	\$ 5,500.00
PAINTING - BANISTERS AND AROUND DOORS		1	\$ 3,400.00	\$ 3,400.00
10 SPECIALTIES				
FIRE EXTINGUISHERS		1	\$ 200.00	\$ 200.00
TOILET ACCESSORIES		1	\$ 600.00	\$ 600.00
MIRRORS		2	\$ 175.00	\$ 350.00
15 MECHANICAL				
PLUMBING		1	\$ 3,900.00	\$ 3,900.00
16 ELECTRICAL				
ELECTRICAL		1	\$ 550.00	\$ 550.00
SUBTOTAL CONSTRUCTION COSTS				\$ 63,850.00
BUILDERS RISK		1	\$ 650.00	\$ 650.00
GENERAL CONDITIONS, INSURANCE, OVERHEAD, PROFIT				\$ 12,900.00
M6 DISCOUNT				\$ (1,290.00)
Total Construction Costs				\$ 76,110.00
CONSTRUCTION CONTINGENCY				\$ 3,192.50
SIGNAGE				\$ -
Total Construction Costs + Contingency				\$ 79,302.50

M6 Builders

m6builders.com - 832.876.7113

scottm@studio-m6.com

Construction Costs
Liedertafel Phase 2
11.19.25

CLIENT: Bill Atkinson, Sealy EDC
ADDRESS: 116 Lux Rd, Sealy, TX 77474

DESCRIPTION	VENDOR	UNITS	UNIT \$	CONTRACT \$
01 GENERAL REQUIREMENTS				
SUPERVISION		10	\$ 1,500.00	\$ 15,000.00
TEMPORARY TOILET			\$ -	\$ -
PLAN REPRODUCTION		1	\$ 250.00	\$ 250.00
TEMPORARY PROTECTION		1	\$ 450.00	\$ 450.00
TRASH HAUL		1	\$ 1,200.00	\$ 1,200.00
DAILY/FINAL CONSTRUCTION CLEANUP		1	\$ 500.00	\$ 500.00
02 DEMOLITION				
DEMOLITION		1	\$ 1,500.00	\$ 1,500.00
05 STEEL				
STEEL HANDRAILS		1	\$ 6,250.00	\$ 6,250.00
06 CARPENTRY				
BUILD STORAGE ROOM 103		1	\$ 15,000.00	\$ 15,000.00
BUILD STORAGE ROOM 107		1	\$ 17,500.00	\$ 17,500.00
BUILD RAMPS AND STAIRS		1	\$ 10,000.00	\$ 10,000.00
CABINETS AND SHELVING INSTALL		1	\$ 1,800.00	\$ 1,800.00
08 DOORS, WINDOWS AND GLASS				
DOORS/FRAMES AND HARDWARE		1	\$ 4,000.00	\$ 4,000.00
09 FINISHES				
LVT FLOORING IN STORAGE ROOMS		1	\$ 2,800.00	\$ 2,800.00
PAINTING - EXT FACIA AND INT DOORS		1	\$ 3,800.00	\$ 3,800.00
10 SPECIALTIES				
KITCHEN SHELVING AND TABLES		1	\$ 1,450.00	\$ 1,450.00
15 MECHANICAL				
PLUMBING - SINKS, RELOCATE WATER HEATER		1	\$ 3,900.00	\$ 3,900.00
HVAC - RELOCATE CONDENSERS, STORAGE SUPPLY DUCT		1	\$ 3,700.00	\$ 3,700.00
16 ELECTRICAL				
ELECTRICAL		1	\$ 4,200.00	\$ 4,200.00
SUBTOTAL CONSTRUCTION COSTS				\$ 93,300.00
BUILDERS RISK		1	\$ 650.00	\$ 650.00
GENERAL CONDITIONS, INSURANCE, OVERHEAD, PROFIT				\$ 18,790.00
M6 DISCOUNT				\$ (1,879.00)
Total Construction Costs				\$ 110,861.00
CONSTRUCTION CONTINGENCY				\$ 4,665.00
SIGNAGE				\$ -
Total Construction Costs + Contingency				\$ 115,526.00

Description	Amount (\$)
Phase I – Total Construction + Contingency (per estimate)	\$79,302.50
Phase II – Total Construction + Contingency (per estimate)	\$115,526.00
Combined Base Project Cost	\$194,828.50
5% Escalation Allowance (assumed April 2026 bid)	\$9,741.43
Subtotal After Escalation	\$204,569.93
15% Project Contingency (applied to subtotal)	\$30,685.49
Total Recommended Project Budget	\$235,255.41

Notes

Phase sheets contain line-item details parsed from the provided PDFs.

Phase totals used in Summary equal the 'Total Construction Costs + Contingency' figures shown on the PDFs.

The 15% project contingency is in addition to the per-phase construction contingencies already included in the estimates.

Liedertafel Hall - Task Order #1

Scope of Work:

- Kitchen renovation
- ADA-compliant restrooms
- ADA front entrance
- New storage room addition

Progress:

- Site investigations completed
- ADA deficiency review has been completed
- Building code review has been completed
- Life safety code review has been completed
- Issue for Construction Drawings has been completed



Kitchen & Storage Revisions



Revised Layout:

- Catering Kitchen: 132 SF
- New Storage: 268 SF
- Additional Storage: 195 SF
- Total Storage: 463 SF

Enhancements:

- 3-compartment sink (code compliance)
- Utility sink relocated to storage room
- Wrap-around counters + shelving
- Multiple outlets above counters

Phase 1

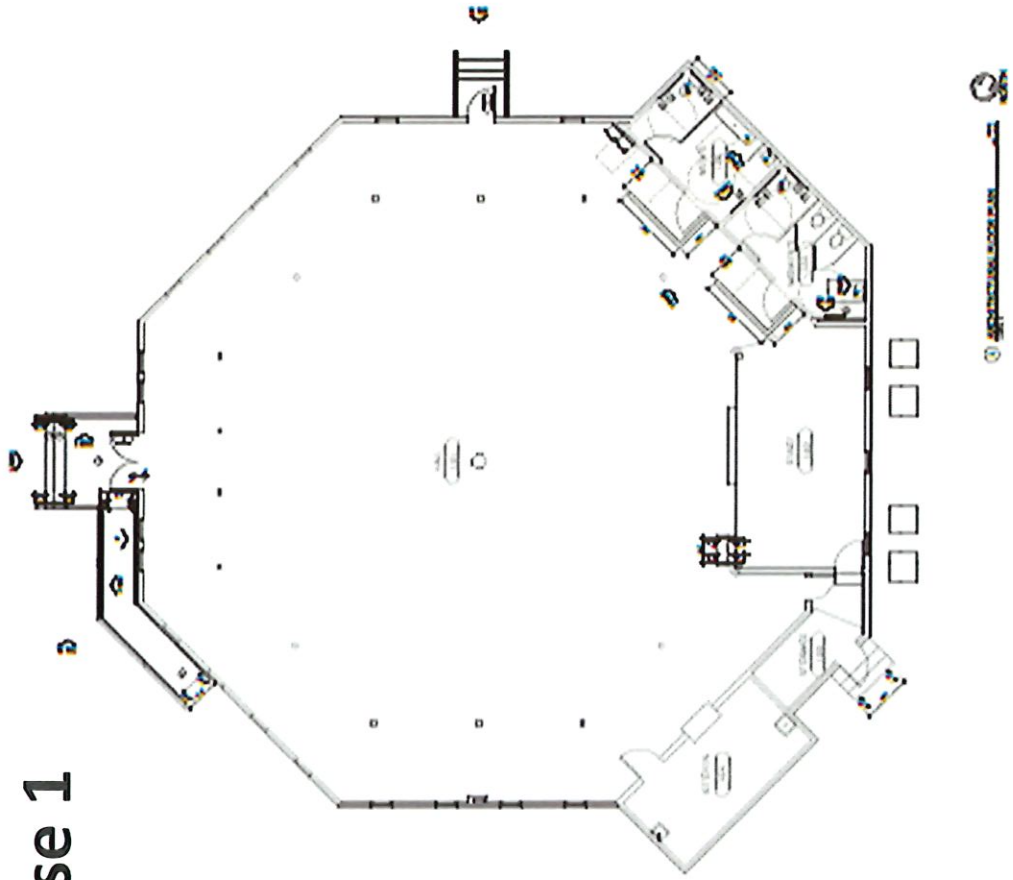

GENERAL NOTES: 1. ALL WORK SHALL BE IN ACCORDANCE WITH THE LATEST EDITIONS OF THE INTERNATIONAL BUILDING CODES AND ALL APPLICABLE LOCAL, STATE AND FEDERAL CODES. 2. THE CONTRACTOR SHALL BE RESPONSIBLE FOR OBTAINING ALL NECESSARY PERMITS AND APPROVALS FROM THE APPROPRIATE AGENCIES. 3. ALL MATERIALS AND WORKMANSHIP SHALL BE SUBJECT TO INSPECTION AND APPROVAL BY THE ARCHITECT AND THE CITY OF HOUSTON. 4. THE CONTRACTOR SHALL MAINTAIN ACCESS TO ALL EXISTING UTILITIES AND STRUCTURES. 5. ALL DEMOLITION WORK SHALL BE DONE IN ACCORDANCE WITH THE CITY OF HOUSTON'S DEMOLITION ORDINANCE. 6. THE CONTRACTOR SHALL BE RESPONSIBLE FOR PROTECTING ALL EXISTING UTILITIES AND STRUCTURES. 7. ALL WORK SHALL BE COMPLETED WITHIN THE SPECIFIED TIME FRAME. 8. THE CONTRACTOR SHALL MAINTAIN A CLEAN AND SAFE WORK SITE AT ALL TIMES. 9. ALL MATERIALS AND WASTE SHALL BE PROPERLY DISPOSED OF AT THE END OF EACH DAY. 10. THE CONTRACTOR SHALL BE RESPONSIBLE FOR OBTAINING ALL NECESSARY INSURANCE AND BONDS. 11. ALL WORK SHALL BE COMPLETED IN ACCORDANCE WITH THE ARCHITECT'S INTENT. 12. THE CONTRACTOR SHALL BE RESPONSIBLE FOR OBTAINING ALL NECESSARY APPROVALS FROM THE ARCHITECT AND THE CITY OF HOUSTON. 13. ALL WORK SHALL BE COMPLETED WITHIN THE SPECIFIED TIME FRAME. 14. THE CONTRACTOR SHALL MAINTAIN A CLEAN AND SAFE WORK SITE AT ALL TIMES. 15. ALL MATERIALS AND WASTE SHALL BE PROPERLY DISPOSED OF AT THE END OF EACH DAY. 16. THE CONTRACTOR SHALL BE RESPONSIBLE FOR OBTAINING ALL NECESSARY INSURANCE AND BONDS. 17. ALL WORK SHALL BE COMPLETED IN ACCORDANCE WITH THE ARCHITECT'S INTENT. 18. THE CONTRACTOR SHALL BE RESPONSIBLE FOR OBTAINING ALL NECESSARY APPROVALS FROM THE ARCHITECT AND THE CITY OF HOUSTON.	DOOR SCHEDULE: 1. ALL DOORS SHALL BE 1-1/2" THICK SOLID CORE DOORS. 2. ALL DOORS SHALL BE 36" HIGH AND 24" WIDE. 3. ALL DOORS SHALL BE SET IN 2" DEEP DOOR CASINGS. 4. ALL DOORS SHALL BE SET IN 2" DEEP DOOR CASINGS. 5. ALL DOORS SHALL BE SET IN 2" DEEP DOOR CASINGS.	WINDOW SCHEDULE: 1. ALL WINDOWS SHALL BE 1/2" THICK ALUMINUM WINDOWS. 2. ALL WINDOWS SHALL BE 36" HIGH AND 24" WIDE. 3. ALL WINDOWS SHALL BE SET IN 2" DEEP WINDOW CASINGS. 4. ALL WINDOWS SHALL BE SET IN 2" DEEP WINDOW CASINGS. 5. ALL WINDOWS SHALL BE SET IN 2" DEEP WINDOW CASINGS.	CEILING SCHEDULE: 1. ALL CEILING SHALL BE 1/2" THICK ALUMINUM CEILING. 2. ALL CEILING SHALL BE 36" HIGH AND 24" WIDE. 3. ALL CEILING SHALL BE SET IN 2" DEEP CEILING CASINGS. 4. ALL CEILING SHALL BE SET IN 2" DEEP CEILING CASINGS. 5. ALL CEILING SHALL BE SET IN 2" DEEP CEILING CASINGS.	FLOOR SCHEDULE: 1. ALL FLOOR SHALL BE 1/2" THICK ALUMINUM FLOOR. 2. ALL FLOOR SHALL BE 36" HIGH AND 24" WIDE. 3. ALL FLOOR SHALL BE SET IN 2" DEEP FLOOR CASINGS. 4. ALL FLOOR SHALL BE SET IN 2" DEEP FLOOR CASINGS. 5. ALL FLOOR SHALL BE SET IN 2" DEEP FLOOR CASINGS.	MECHANICAL SCHEDULE: 1. ALL MECHANICAL SHALL BE 1/2" THICK ALUMINUM MECHANICAL. 2. ALL MECHANICAL SHALL BE 36" HIGH AND 24" WIDE. 3. ALL MECHANICAL SHALL BE SET IN 2" DEEP MECHANICAL CASINGS. 4. ALL MECHANICAL SHALL BE SET IN 2" DEEP MECHANICAL CASINGS. 5. ALL MECHANICAL SHALL BE SET IN 2" DEEP MECHANICAL CASINGS.
---	---	---	---	---	---

studio M6
105 Elm Rd, Socky, TX 77474

LIEDERTAFEL HALL

A-201

studio M6

LIEDERTAFEL HALL

156 Luk Rd, Seely, TX 77474



A-221

- DISCIPLINE GENERAL NOTES:**
- 1. REFER TO ALL GENERAL NOTES AND SPECIFICATIONS.
 - 2. VERIFY ALL DIMENSIONS AND LOCATIONS BEFORE CONSTRUCTION.
 - 3. VERIFY ALL MATERIALS AND FINISHES BEFORE CONSTRUCTION.
 - 4. VERIFY ALL PERMITS AND REGULATIONS BEFORE CONSTRUCTION.

FINISH SCHEDULE:

NO.	FINISH	DESCRIPTION
1	CONCRETE FLOOR	CONCRETE FLOOR
2	PAINT	PAINT
3	CEILING	CEILING
4	WALLS	WALLS
5	DOORS	DOORS
6	WINDOWS	WINDOWS
7	MECHANICAL	MECHANICAL
8	ELECTRICAL	ELECTRICAL
9	PLUMBING	PLUMBING
10	MECHANICAL	MECHANICAL
11	ELECTRICAL	ELECTRICAL
12	PLUMBING	PLUMBING

- GENERAL NOTES:**
- 1. VERIFY ALL DIMENSIONS AND LOCATIONS BEFORE CONSTRUCTION.
 - 2. VERIFY ALL MATERIALS AND FINISHES BEFORE CONSTRUCTION.
 - 3. VERIFY ALL PERMITS AND REGULATIONS BEFORE CONSTRUCTION.

Phase 1

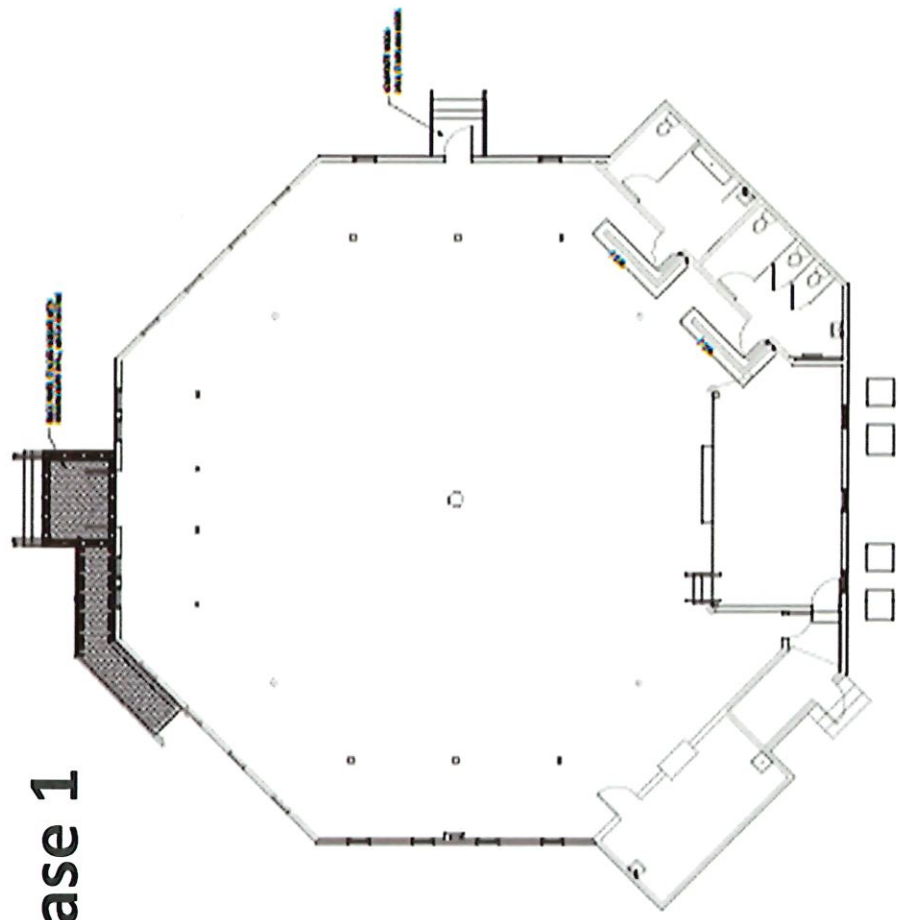

Phase 1

LIEDERTAFEL HALL

116 Luk Rd., Seely, TX 77474

studio M6

116 Luk Rd., Seely, TX 77474
 281-338-1166
 www.studiom6.com

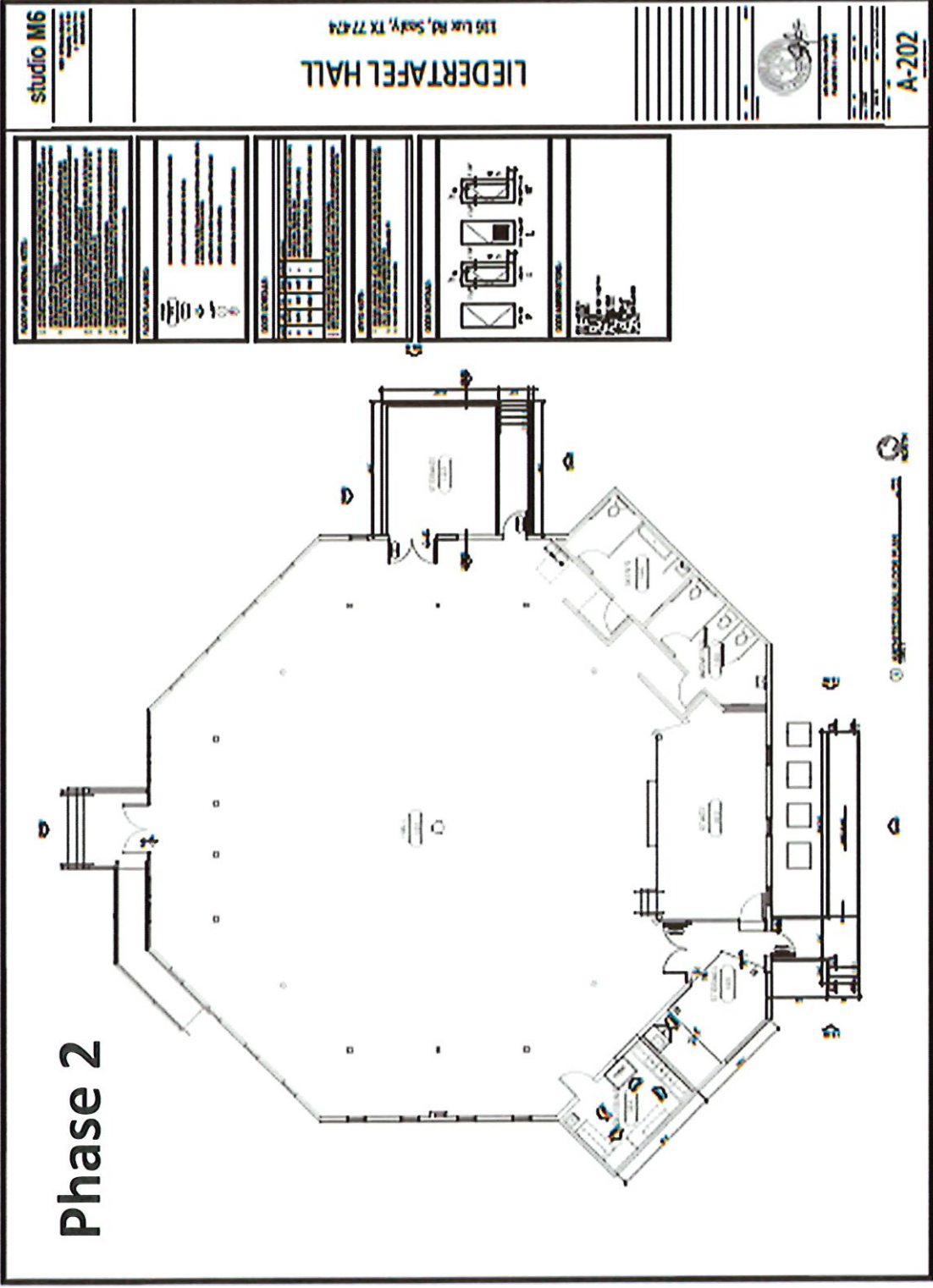

Phase 2

studio M6

116 LUX RD, SOKOLY, TX 77474

LIEDERTAFEL HALL

116 LUX RD, SOKOLY, TX 77474



A-302

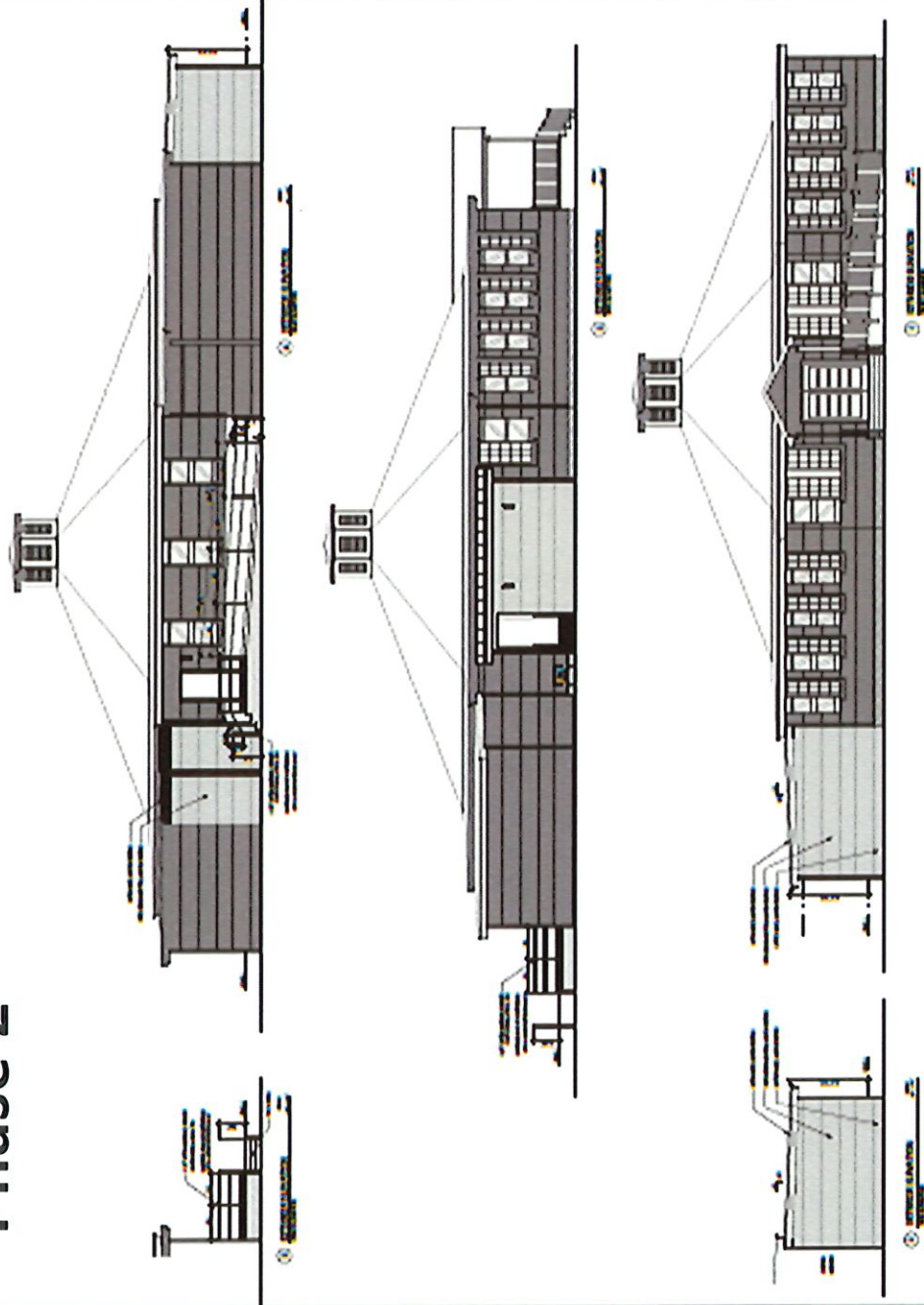

Phase 2

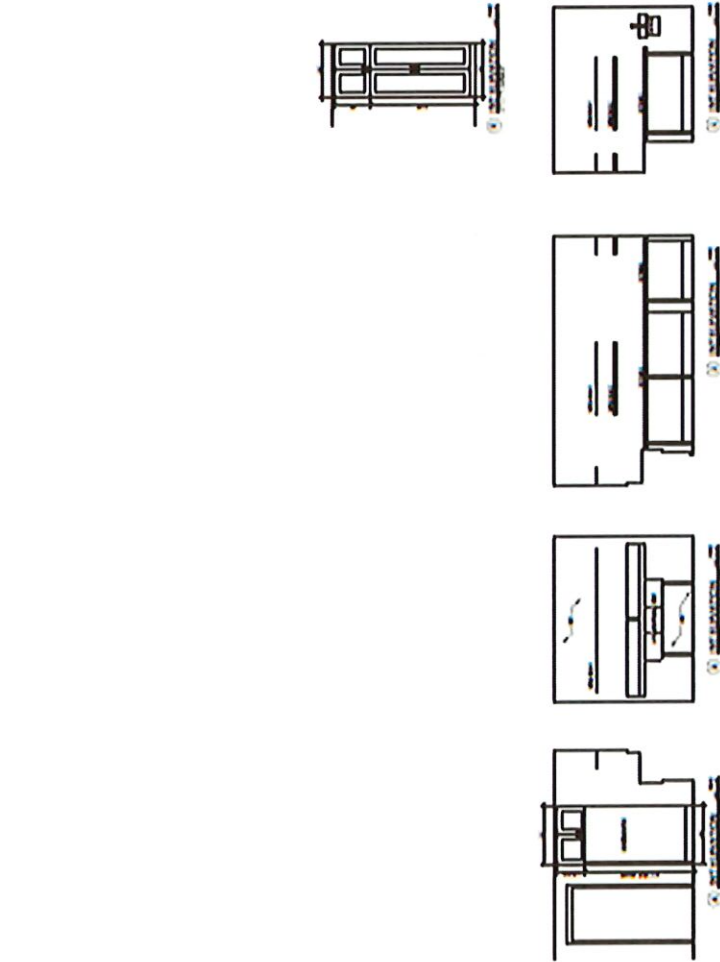
<p>studio M6</p>	<p>Phase 2</p>	<p>studio M6</p>
<p>116 Elm Rd, Saly, TX 77424</p>	<p>LIEDERTAFEL HALL</p>	<p>116 Elm Rd, Saly, TX 77424</p>
		<p>A-602</p>

Benefits of Liedertafel Hall Project

- ADA compliance balanced with historic preservation
- Expanded storage for events & operations
- Functional, code-compliant catering support
- Improved service flow with back entry



Past to the Future Community Impact



studio M6



Liedertafel Hall - Sealy, Texas

INDEX TO DRAWINGS

01.00	GENERAL NOTES
02.00	FOUNDATION
03.00	EXTERIOR WALLS
04.00	ROOFING
05.00	INTERIOR WALLS
06.00	FLOORING
07.00	MECHANICAL
08.00	ELECTRICAL
09.00	PAINTS AND FINISHES
10.00	ARCHITECTURAL

Architect:
studio M6
Scott Maddox, RA, CDT, LEED AP
1101 W. Primm Blvd Dr
Nederland, Texas 77657
832.876.7113
stom@studio-m6.com

Building Owner:
City of Sealy
818 Adams
302 Main Street, Suite B
Sealy, Texas 77474
979.827.6121
barkins@cityofsealy.tx.us

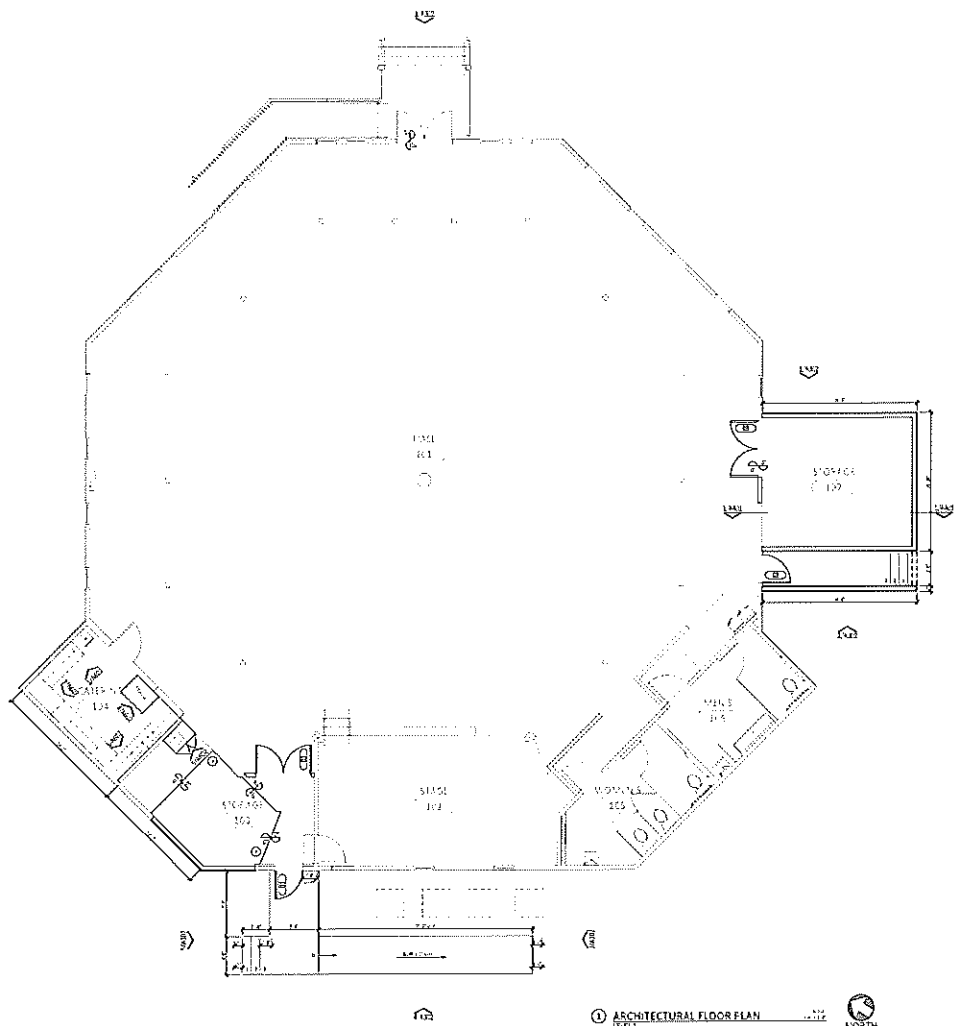

1 ARCHITECTURAL FLOOR PLAN
 1:12 NORTH

FLOOR PLAN GENERAL NOTES

1. ALL WORK SHALL BE IN ACCORDANCE WITH THE LATEST EDITIONS OF THE BUILDING CODES AND SPECIFICATIONS.
2. ALL MATERIALS SHALL BE OF THE BEST QUALITY AND SHALL BE APPROVED BY THE ARCHITECT.
3. ALL WORK SHALL BE DONE IN ACCORDANCE WITH THE LATEST EDITIONS OF THE BUILDING CODES AND SPECIFICATIONS.
4. ALL WORK SHALL BE DONE IN ACCORDANCE WITH THE LATEST EDITIONS OF THE BUILDING CODES AND SPECIFICATIONS.
5. ALL WORK SHALL BE DONE IN ACCORDANCE WITH THE LATEST EDITIONS OF THE BUILDING CODES AND SPECIFICATIONS.
6. ALL WORK SHALL BE DONE IN ACCORDANCE WITH THE LATEST EDITIONS OF THE BUILDING CODES AND SPECIFICATIONS.
7. ALL WORK SHALL BE DONE IN ACCORDANCE WITH THE LATEST EDITIONS OF THE BUILDING CODES AND SPECIFICATIONS.
8. ALL WORK SHALL BE DONE IN ACCORDANCE WITH THE LATEST EDITIONS OF THE BUILDING CODES AND SPECIFICATIONS.
9. ALL WORK SHALL BE DONE IN ACCORDANCE WITH THE LATEST EDITIONS OF THE BUILDING CODES AND SPECIFICATIONS.
10. ALL WORK SHALL BE DONE IN ACCORDANCE WITH THE LATEST EDITIONS OF THE BUILDING CODES AND SPECIFICATIONS.

FLOOR PLAN LEGEND

EXAM - EXAMINATION ROOM
 STAIR - STAIRS
 MEN - MEN'S RESTROOM
 WOMEN - WOMEN'S RESTROOM
 STORAGE - STORAGE ROOM
 OFFICE - OFFICE

DOOR SCHEDULE

NO.	TYPE	FINISH	MARK
1	STANDARD	WOOD	101
2	GLASS	GLASS	102
3	GLASS	GLASS	103
4	GLASS	GLASS	104
5	GLASS	GLASS	105
6	GLASS	GLASS	106
7	GLASS	GLASS	107
8	GLASS	GLASS	108
9	GLASS	GLASS	109
10	GLASS	GLASS	110

LEVEL NOTE

1. ALL LEVELS SHALL BE IN ACCORDANCE WITH THE LATEST EDITIONS OF THE BUILDING CODES AND SPECIFICATIONS.

DOOR SCHEDULE

DOOR ABBREVIATIONS

SW - SWING
 GL - GLASS
 ST - STAIR
 MEN - MEN'S RESTROOM
 WOMEN - WOMEN'S RESTROOM
 STORAGE - STORAGE ROOM
 OFFICE - OFFICE

studio M6

116 Lux Rd, Sealy, TX 77474

LIEDERTAFEL HALL

116 Lux Rd, Sealy, TX 77474

REGISTERED ARCHITECT
 AIA 104117000

DATE: 11/11/11
 PROJECT: LIEDERTAFEL HALL
 SHEET: A-202

A-202

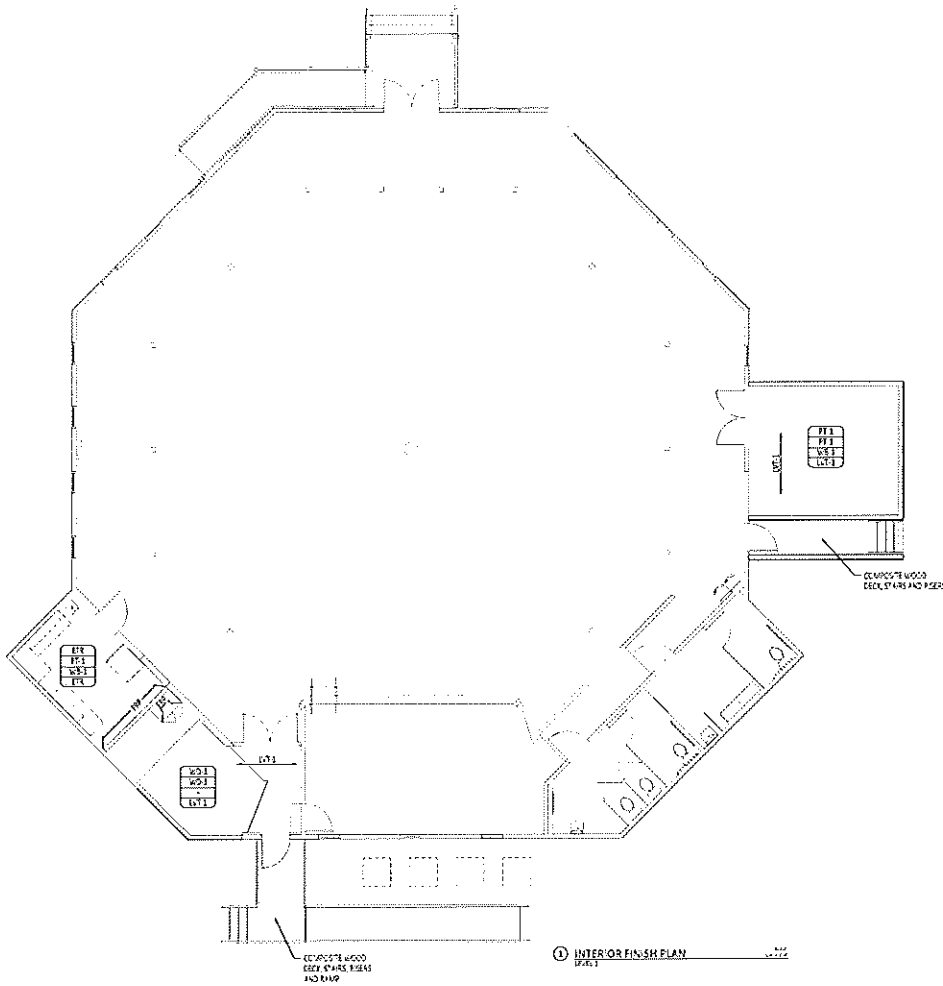

FINISH PLAN GENERAL NOTES:

1. ALL FINISHES TO BE IN ACCORDANCE WITH THE LATEST EDITIONS OF THE SPECIFICATIONS FOR FINISHES AND MATERIALS.
2. ALL FINISHES TO BE IN ACCORDANCE WITH THE LATEST EDITIONS OF THE SPECIFICATIONS FOR FINISHES AND MATERIALS.
3. ALL FINISHES TO BE IN ACCORDANCE WITH THE LATEST EDITIONS OF THE SPECIFICATIONS FOR FINISHES AND MATERIALS.

NOTES & LEGEND:

CS	CONCRETE
ST	STEEL
GL	GLASS
DR	DRY WALL
PT	PAINT
WT	WOOD
MT	METAL
ST	STAINLESS STEEL

GYPSUM BOARD NOTES:

1. ALL GYPSUM BOARD TO BE 5/8" THICK TYPE X GYPSUM BOARD.
2. ALL GYPSUM BOARD TO BE TYPE X GYPSUM BOARD.
3. ALL GYPSUM BOARD TO BE TYPE X GYPSUM BOARD.
4. ALL GYPSUM BOARD TO BE TYPE X GYPSUM BOARD.
5. ALL GYPSUM BOARD TO BE TYPE X GYPSUM BOARD.

studio M6
 1116 North Loop East
 Suite 1000
 Houston, TX 77028
 P: 713.867.1111
 E: info@studioM6.com

LIEDERTAFEL HALL
 116 Lux Rd, Sealy, TX 77474

Professional seal and stamp area. Includes a circular seal with a star and the text 'REGISTERED ARCHITECT' and 'PLAN LEVEL 1'. Below the seal is a table for project information:

PROJECT NO.	
DATE	
SCALE	
BY	
CHECKED BY	

A-222

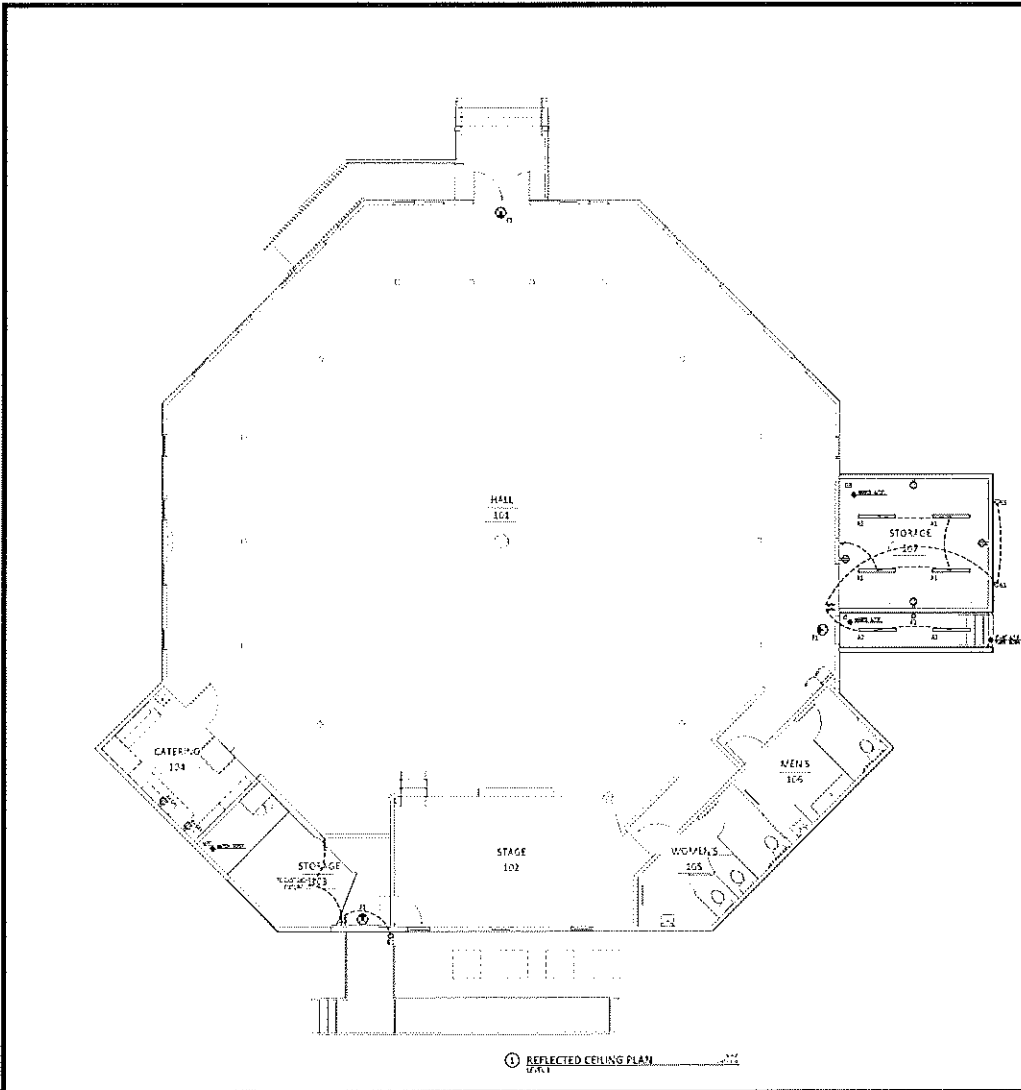

ELECTRICAL POWER PLAN GENERAL NOTES

1. ALL ELECTRICAL WORK SHALL BE IN ACCORDANCE WITH THE LATEST EDITIONS OF THE NATIONAL ELECTRICAL CODE (NEC) AND THE NATIONAL FIRE ALARM AND SIGNAL CODE (NFPA 72).
2. ALL ELECTRICAL WORK SHALL BE INSTALLED IN ACCORDANCE WITH THE LATEST EDITIONS OF THE NATIONAL ELECTRICAL CODE (NEC) AND THE NATIONAL FIRE ALARM AND SIGNAL CODE (NFPA 72).
3. ALL ELECTRICAL WORK SHALL BE INSTALLED IN ACCORDANCE WITH THE LATEST EDITIONS OF THE NATIONAL ELECTRICAL CODE (NEC) AND THE NATIONAL FIRE ALARM AND SIGNAL CODE (NFPA 72).
4. ALL ELECTRICAL WORK SHALL BE INSTALLED IN ACCORDANCE WITH THE LATEST EDITIONS OF THE NATIONAL ELECTRICAL CODE (NEC) AND THE NATIONAL FIRE ALARM AND SIGNAL CODE (NFPA 72).
5. ALL ELECTRICAL WORK SHALL BE INSTALLED IN ACCORDANCE WITH THE LATEST EDITIONS OF THE NATIONAL ELECTRICAL CODE (NEC) AND THE NATIONAL FIRE ALARM AND SIGNAL CODE (NFPA 72).
6. ALL ELECTRICAL WORK SHALL BE INSTALLED IN ACCORDANCE WITH THE LATEST EDITIONS OF THE NATIONAL ELECTRICAL CODE (NEC) AND THE NATIONAL FIRE ALARM AND SIGNAL CODE (NFPA 72).
7. ALL ELECTRICAL WORK SHALL BE INSTALLED IN ACCORDANCE WITH THE LATEST EDITIONS OF THE NATIONAL ELECTRICAL CODE (NEC) AND THE NATIONAL FIRE ALARM AND SIGNAL CODE (NFPA 72).
8. ALL ELECTRICAL WORK SHALL BE INSTALLED IN ACCORDANCE WITH THE LATEST EDITIONS OF THE NATIONAL ELECTRICAL CODE (NEC) AND THE NATIONAL FIRE ALARM AND SIGNAL CODE (NFPA 72).
9. ALL ELECTRICAL WORK SHALL BE INSTALLED IN ACCORDANCE WITH THE LATEST EDITIONS OF THE NATIONAL ELECTRICAL CODE (NEC) AND THE NATIONAL FIRE ALARM AND SIGNAL CODE (NFPA 72).
10. ALL ELECTRICAL WORK SHALL BE INSTALLED IN ACCORDANCE WITH THE LATEST EDITIONS OF THE NATIONAL ELECTRICAL CODE (NEC) AND THE NATIONAL FIRE ALARM AND SIGNAL CODE (NFPA 72).

NOTES & LEGEND

- 120V AC 15A RECEPTACLE
- △ 208V AC 15A RECEPTACLE
- ▲ 208V AC 30A RECEPTACLE
- 208V AC 30A RECEPTACLE
- ⊥ 208V AC 30A RECEPTACLE

ELECTRICAL LIGHTING PLAN GENERAL NOTES

1. ALL LIGHTING SHALL BE INSTALLED IN ACCORDANCE WITH THE LATEST EDITIONS OF THE NATIONAL ELECTRICAL CODE (NEC) AND THE NATIONAL FIRE ALARM AND SIGNAL CODE (NFPA 72).
2. ALL LIGHTING SHALL BE INSTALLED IN ACCORDANCE WITH THE LATEST EDITIONS OF THE NATIONAL ELECTRICAL CODE (NEC) AND THE NATIONAL FIRE ALARM AND SIGNAL CODE (NFPA 72).
3. ALL LIGHTING SHALL BE INSTALLED IN ACCORDANCE WITH THE LATEST EDITIONS OF THE NATIONAL ELECTRICAL CODE (NEC) AND THE NATIONAL FIRE ALARM AND SIGNAL CODE (NFPA 72).
4. ALL LIGHTING SHALL BE INSTALLED IN ACCORDANCE WITH THE LATEST EDITIONS OF THE NATIONAL ELECTRICAL CODE (NEC) AND THE NATIONAL FIRE ALARM AND SIGNAL CODE (NFPA 72).
5. ALL LIGHTING SHALL BE INSTALLED IN ACCORDANCE WITH THE LATEST EDITIONS OF THE NATIONAL ELECTRICAL CODE (NEC) AND THE NATIONAL FIRE ALARM AND SIGNAL CODE (NFPA 72).
6. ALL LIGHTING SHALL BE INSTALLED IN ACCORDANCE WITH THE LATEST EDITIONS OF THE NATIONAL ELECTRICAL CODE (NEC) AND THE NATIONAL FIRE ALARM AND SIGNAL CODE (NFPA 72).
7. ALL LIGHTING SHALL BE INSTALLED IN ACCORDANCE WITH THE LATEST EDITIONS OF THE NATIONAL ELECTRICAL CODE (NEC) AND THE NATIONAL FIRE ALARM AND SIGNAL CODE (NFPA 72).
8. ALL LIGHTING SHALL BE INSTALLED IN ACCORDANCE WITH THE LATEST EDITIONS OF THE NATIONAL ELECTRICAL CODE (NEC) AND THE NATIONAL FIRE ALARM AND SIGNAL CODE (NFPA 72).
9. ALL LIGHTING SHALL BE INSTALLED IN ACCORDANCE WITH THE LATEST EDITIONS OF THE NATIONAL ELECTRICAL CODE (NEC) AND THE NATIONAL FIRE ALARM AND SIGNAL CODE (NFPA 72).
10. ALL LIGHTING SHALL BE INSTALLED IN ACCORDANCE WITH THE LATEST EDITIONS OF THE NATIONAL ELECTRICAL CODE (NEC) AND THE NATIONAL FIRE ALARM AND SIGNAL CODE (NFPA 72).

NOTES & LEGEND

- 120V AC 15A RECEPTACLE
- 208V AC 15A RECEPTACLE
- 208V AC 30A RECEPTACLE
- 120V AC 15A RECEPTACLE
- 208V AC 15A RECEPTACLE
- 208V AC 30A RECEPTACLE
- 120V AC 15A RECEPTACLE
- 208V AC 15A RECEPTACLE
- 208V AC 30A RECEPTACLE
- 120V AC 15A RECEPTACLE
- 208V AC 15A RECEPTACLE
- 208V AC 30A RECEPTACLE
- 120V AC 15A RECEPTACLE
- 208V AC 15A RECEPTACLE
- 208V AC 30A RECEPTACLE

LIGHT FIXTURE SCHEDULE

NO.	DESCRIPTION	QTY	DATE	REVISION
1	120V AC 15A RECEPTACLE	1	10/10/10	1
2	208V AC 15A RECEPTACLE	1	10/10/10	1
3	208V AC 30A RECEPTACLE	1	10/10/10	1
4	120V AC 15A RECEPTACLE	1	10/10/10	1
5	208V AC 15A RECEPTACLE	1	10/10/10	1
6	208V AC 30A RECEPTACLE	1	10/10/10	1
7	120V AC 15A RECEPTACLE	1	10/10/10	1
8	208V AC 15A RECEPTACLE	1	10/10/10	1
9	208V AC 30A RECEPTACLE	1	10/10/10	1
10	120V AC 15A RECEPTACLE	1	10/10/10	1
11	208V AC 15A RECEPTACLE	1	10/10/10	1
12	208V AC 30A RECEPTACLE	1	10/10/10	1

studio M6
116 Lux Rd, Sealy, TX 77474

LIEDERTAFEL HALL
116 Lux Rd, Sealy, TX 77474

A-242

REGISTERED ELECTRICAL ENGINEER
STATE OF TEXAS
NO. 12345
EXPIRES 12/31/2024

studio M6

11514 Beech Street
Houston, TX 77031
P 281.747.7777
R 281.747.4128

LIEDERTAFEL HALL

116 Lux Rd, Sealy, TX 77474

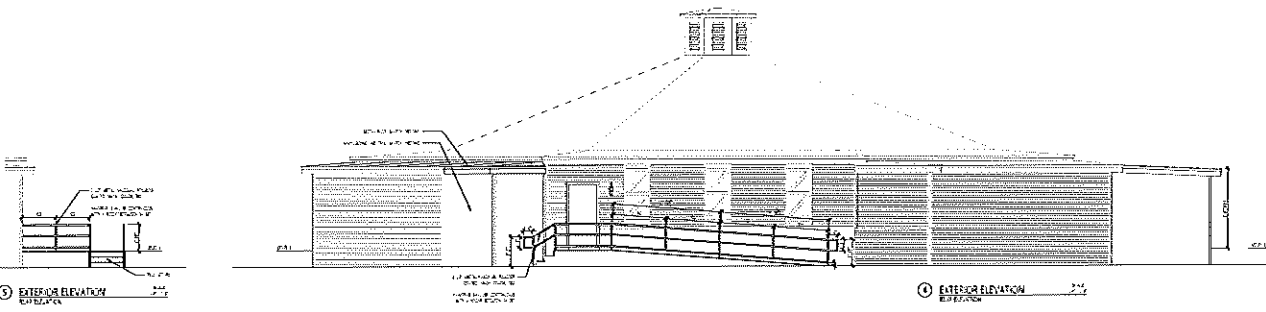

⑤ EXTERIOR ELEVATION
ELEVATION

④ EXTERIOR ELEVATION
ELEVATION

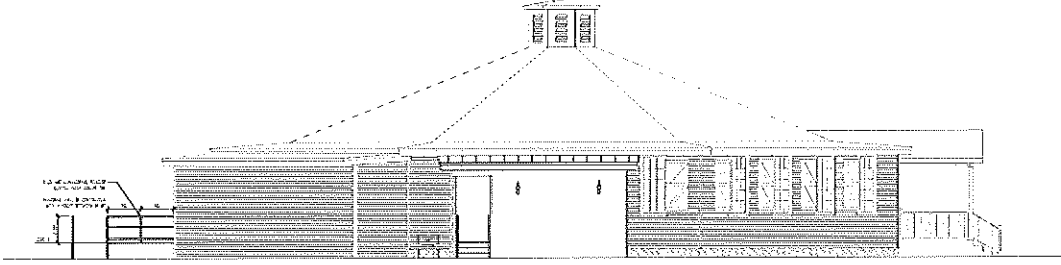

③ EXTERIOR ELEVATION
ELEVATION

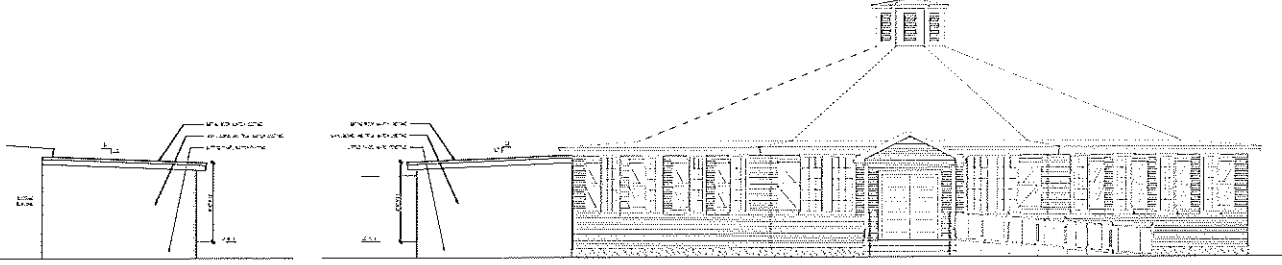

② EXTERIOR ELEVATION
ELEVATION

① EXTERIOR ELEVATION
ELEVATION



A-302

studio M6

12214 Forest Road
Dallas, TX 75243
972.353.1100
www.studiom6.com

LIEDERTAFEL HALL

116 Lux Rd, Sealy, TX 77474



TOILET ACCESSORIES
SCHEDULE

A-545

TOILET ACCESSORIES LEGEND & MOUNTING HEIGHTS (ANSI)

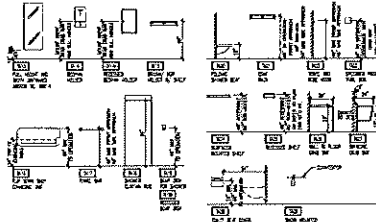
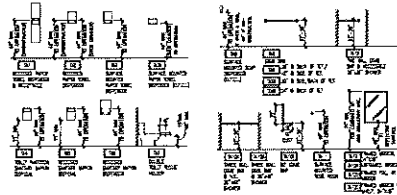

ENLARGED PLAN GENERAL NOTES

1. ALL TOILET ACCESSORIES SHALL BE INSTALLED AT THE CENTER OF THE TOILET EXCEPT AS NOTED OTHERWISE.
2. TOILET ACCESSORIES SHALL BE INSTALLED AT THE CENTER OF THE TOILET EXCEPT AS NOTED OTHERWISE.
3. TOILET ACCESSORIES SHALL BE INSTALLED AT THE CENTER OF THE TOILET EXCEPT AS NOTED OTHERWISE.
4. TOILET ACCESSORIES SHALL BE INSTALLED AT THE CENTER OF THE TOILET EXCEPT AS NOTED OTHERWISE.
5. TOILET ACCESSORIES SHALL BE INSTALLED AT THE CENTER OF THE TOILET EXCEPT AS NOTED OTHERWISE.
6. TOILET ACCESSORIES SHALL BE INSTALLED AT THE CENTER OF THE TOILET EXCEPT AS NOTED OTHERWISE.
7. TOILET ACCESSORIES SHALL BE INSTALLED AT THE CENTER OF THE TOILET EXCEPT AS NOTED OTHERWISE.
8. TOILET ACCESSORIES SHALL BE INSTALLED AT THE CENTER OF THE TOILET EXCEPT AS NOTED OTHERWISE.
9. TOILET ACCESSORIES SHALL BE INSTALLED AT THE CENTER OF THE TOILET EXCEPT AS NOTED OTHERWISE.
10. TOILET ACCESSORIES SHALL BE INSTALLED AT THE CENTER OF THE TOILET EXCEPT AS NOTED OTHERWISE.

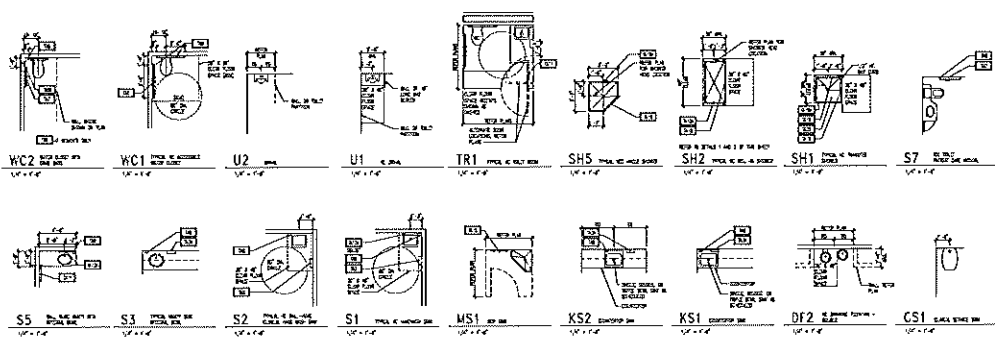

studio M6

1221 Alton Street
Austin, TX 78701
512.477.1111
studioM6.com

LIEDERTAFEL HALL

116 Lux Rd, Seely, TX 77474

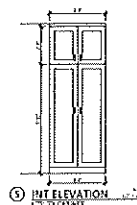
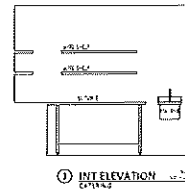
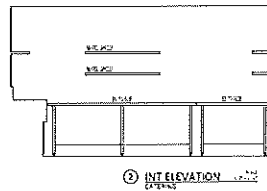
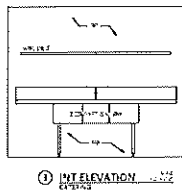
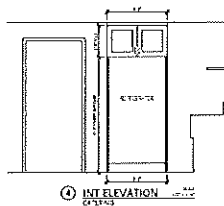

REGISTERED ARCHITECT
STATE OF TEXAS
No. 12345
Exp. 12/31/2025

A-602

Sealy Economic Development Corporation Projects Status and Updates February 13, 2026

Liedertafel Hall Renovation & Historic Coordination

Staff consulted with the Texas Historical Commission (THC) regarding additional historic designation options for Liedertafel Hall. THC advised that due to alterations made over time, pursuing designations beyond its current Recorded Texas Historic Landmark (RTHL) status would require extensive documentation, potential design changes, and significant financial investment to meet higher integrity standards. This process would likely be time-consuming and could delay the project.

Based on this guidance, staff recommends proceeding under the existing RTHL designation, maintaining compliance with the Texas Antiquities Code while preserving fiscal and scheduling flexibility. Staff further recommends moving forward with the preparation and release of a construction bid package, including alternates to determine full build feasibility and potential phasing options.

I. Council Action – Study of THC Building Designation & Initial Recommendation

March 3, 2026 – Requested Action

City Council is requested to:

- Consider staff's recommendation based on research and consultation with THC to proceed under the current designation of Recorded Texas Historic Landmark (RTHL).
- Purpose of This Step:
- Establish regulatory clarity under the Texas Antiquities Code (ACT).
- Confirm compliance requirements prior to procurement.
- Protect the project schedule by clarifying designation status before bid release.

II. Authorization to Bid

March 3, 2026 – Concurrent Action

Council action requested to:

- Authorize staff to proceed to bid the project as presented.
- Direct inclusion of alternative bid options to determine:
- Full build feasibility within current plans
- Whether the project must be phased
- Whether total project cost exceeds available funding

Purpose of Action:

Establish procurement authority while preserving flexibility based on competitive bid results.

III. Bid Release & Cost Determination

March – April 2026

- Finalize construction documents
- Obtain required ACT clearance
- Release project for competitive bidding
- Include additive/deductive alternates to establish:
 - Base project cost
 - Priority scope pricing
 - Phase 2 options if required

Bid Results Will Determine:

- Whether the project can be completed within available funding
 - Whether phased construction is required
 - Whether a budget amendment is recommended
-

IV. Construction & Implementation

- Spring–Summer 2026 (Pending Bid Results)
 - Award contract
 - Implement full scope or Phase 1 construction
 - Identify remaining improvements for future fiscal cycle if applicable
-

V. Fiscal Framework

- Available FY 2025–2026 Funding:
- Sealy EDC Contribution: \$75,000
- Additional Allocation: \$35,475
- Total Available: \$110,475

Bid alternates will provide objective cost data to guide the following approaches:

- Option A – Full Build Within Budget
Proceed with entire project scope.
 - Option B – Phased Implementation
Construct priority improvements now; schedule remaining scope in a future fiscal year.
 - Option C – Budget Amendment
Amend FY 2025–2026 budget to accommodate full build.
-

VI. Strategic Considerations

- Maintains compliance with Texas Antiquities Code.
 - Protects project schedule by clarifying designation status prior to bid.
 - Provides transparent cost determination through competitive procurement.
 - Aligns with Downtown Redevelopment and long-term placemaking objectives.
-

ITEM #5



AGENDA ITEM NO: _____

SUBMITTED BY: Mike Barrow, Assistant City Manager

MEETING DATE: March 3, 2026

STAFF REPORT

DESCRIPTION

Discussion and Possible Action regarding Review and Consideration of Amendments to Ordinance Chapter 42 – Food Trucks.

ANALYSIS

Texas HB 2844 in 2025 creates a single, statewide health permit for mobile food vendors, eliminating the need to obtain separate permits in every city. Effective July 1, 2026, the license is issued by the Texas Department of State Health Services (TDSHS). Essentially local health permits issued will be replaced by the state's permits. Local authorities can still provide annual fire inspections for food trucks.

Texas Municipal League (TML) provided updates, including HB 2844 August 15, 2025 below.

Mobile Food Vendors

H.B. 2844 specifically preempts a local authority, including a city or public health authority, from prohibiting or regulating mobile food vendors in a manner that conflicts with the bill. A local authority may not prohibit the operation in its jurisdiction of a mobile food vendor who holds a mobile food vendor license and complies with all other state and local laws not in conflict with the bill. It applies to an ordinance, rule, regulation, policy, or procedure adopted before, on, or after the bill's effective date, thus preempting any city regulation that conflicts with the bill.

However, H.B. 2844 provides that a mobile food vendor must comply with all state and local laws in the jurisdiction in which the mobile food vendor operates, including all fire codes, **location restrictions**, and zoning codes. This means that a city can still have zoning regulations and/or location restrictions for where a mobile food vendor may operate.

On request by a local authority, DSHS may enter into a collaborative agreement with the local authority for conducting health inspections. DSHS shall reimburse the local authority acting under a collaborative agreement for the cost of conducting a health inspection using money collected for health inspection fees.

The bill also prohibits a person from operating as a mobile food vendor in Texas unless the person holds a mobile food vendor's license issued by DSHS. Each food vending vehicle that a food vendor operates must have a separate license. The executive commissioner of DSHS may adopt rules to implement the bill.

H.B. 2844 requires DSHS to establish and maintain a statewide database that includes: (1) names of mobile food vendors licensed under the bill; (2) results of health inspections of mobile food vendors' food vending vehicles, including inspection reports; (3) public complaints made against mobile food vendors resulting in disciplinary or corrective action; and (4) itineraries of the location of a mobile food vendor's food vending vehicles.

RECOMMENDATION

We need discussion on this new law and changes that will be required of Chapter 42 of our ordinances to make sure that we regulate food trucks to the extent that we can by requiring application for permit approval for location and annual commercial fire safety inspection.

FINANCIAL IMPACTS

Potential loss of health permit revenue, possibly offset by somewhat lower permit fees for regulation of location and annual commercial fire inspection since there will not be health inspections.

City Council's Legal & Project Priorities as of January 7, 2025

ITEM	LERMA	NOACK	MILLER	CURRY	ZAPALAC	BURTSCHHELL	MAYOR
PROJECTS PRIORITIZED BY 6 OUT OF 7:							
Ch. 42: Food Truck *							
Create Ord to Ban Don. Box							
Disannex. Limb Pile Site							
Sick Pay-Out *							
PROJECTS PRIORITIZED BY 5 OUT OF 7:							
Non-Profit Utility Rates							
Ch. 29: Downtown Businesses							
Excess Vacation Pay-Out*							
Tow Permit Ordinance Update							
Merrit Plan Added to Policy							
PROJECTS PRIORITIZED BY 4 OUT OF 7:							
Ord. Req Sub/Apt: Flock Cam**							
Study to Increase Parkland Fees							
Parking: Add Senior Living Reqs							
Election Re: Zoning							
PROJECTS THAT DID NOT RECEIVE MAJORITY APPROVAL as Priority, Hold or Remove from List							
Ch. 70: Conduct in Parks							
Create False Alarm Ord & Fee							
Ch 80: Review Sign Ordinance							
Facility Rental Agreements							
Move Mic System to Council Ch							
Create Scooter Safety Ord							
Create Drone Use Ord							
Ord. Req. HOA Registration w/city							
Plan to address ACESD#2 Sales Tax							
Purchase of Doc Control Software							
Create Man. Home Des. Area							
Man. Home Ord., Option #2							
COUNCIL CONSENSUS: PUT ON HOLD							
Ch. 58: RV Duration of stay							
8-Liner Ordinance							
Create Scooter Rental Ord.							
Allow Septic if City cannot serve							
COUNCIL CONSENSUS: REMOVE FROM LIST							
Agreement with KC Hall as Shelter							
Election to Reduce EDC Tax Rate							
*Goals Vary Between Council							
**As long as there is no financial burden to City							

The following items will be presented for discussion and possible action:

- City Council’s previous requests for Chapter 42 amendments regarding food truck location, use of generators, and authority to ban.
- Review of Chapter 42.
- Amendments to the ordinance that are required to bring it into compliance with State law (HB 2844), which are set to take effect on July 1, 2026.

CITY COUNCIL’S PREVIOUS DISCUSSION/REQUESTS:

CITY COUNCIL'S PROJECT/LEGAL PRIORITIES IDENTIFIED BY INDIVIDUAL VOTE FOLLOWING PRESENTATION/DISCUSSION: JANUARY 7, 2025

ITEM	LERMA	NOACK	MILLER	CURRY	ZAPALAC	BURTTSCHELL	MAYOR
1. Chapter 42: Food Truck Ordinance	Yes. To allow food trucks near schools and include ice cream trucks	Yes. Minor updates to allow selling ice cream, etc.	Yes: Are there any ways to treat them as taxable business to report sales tax?	Put on Hold	Yes. Ban Food Trucks.	Yes. Look into restricting truck and have a dedicated park	Yes

DISCUSSION: Not allowed at schools, parks or vending from streets; add provisions for ice cream vendors; Not allow to plug in to generators – too loud. Issue with using up too much parking that was approved for a (one) business or building; safety concerns with traffic safety concerns and people parking across the street then running across the road to buy food from a truck, kids running across the parking lot and in traffic zones; "Are we for or against food trucks in the community, other than schools that use them at events and fundraisers?" Asked to review 42 c, d and e – So staff can either enforce or amend the ordinance.

Further discussion and possible amendments to Chapter 42 were put on hold pending the State’s legislative updates, specifically regarding **House Bill 2844**.

HOUSE BILL 2844:

The "**Food Truck Freedom Act**" in Texas, also known as House Bill 2844, is a bill that aims to streamline the permitting process for food trucks by creating a single, statewide health permit. This bill eliminates the need for food truck operators to obtain separate permits and undergo multiple inspections in different cities. The bill was recently signed into law and is set to take effect on July 1, 2026, following the creation of the statewide permit by the Texas Department of State Health Services (DSHS).

Here's a more detailed breakdown:

Streamlined Permitting:

HB 2844 establishes a uniform, statewide health permit for food trucks, issued by the DSHS.

Eliminates Redundancy:

This means food truck owners won't have to navigate different health codes and undergo multiple inspections in various cities and counties.

Focus on Statewide Standards:

The bill ensures that mobile food vendors are held to consistent, high health standards while operating across the state.

Local Control Preserved:

While simplifying the permitting process, the bill still allows cities to enforce local regulations regarding where and when food trucks can operate, such as zoning rules and hours of operation.

Economic Impact:

The legislation is designed to reduce costs for food truck owners by eliminating redundant fees and permitting requirements, allowing them to reinvest those savings into their businesses.

Bipartisan Support:

The bill received strong bipartisan support in both the Texas House and Senate.

Effective Date:

The statewide permit and DSHS-run inspection program are set to go live on July 1, 2026.

Chapter 42 HEALTH AND SANITATION¹

- Sections for discussion are in gray boxes:

ARTICLE I. IN GENERAL

Secs. 42-1—42-30. Reserved.

ARTICLE II. FOOD²

DIVISION 1. GENERALLY

¹Charter reference(s)—Health and sanitary regulations, § 2.01.

Cross reference(s)—Animals, ch. 10; rabies vaccination, § 10-34; buildings and building regulations, ch. 14; environment, ch. 30; floods, ch. 38; manufactured homes and trailers, ch. 58; smoking or possession of burning tobacco product, § 66-71 et seq.; solid waste, ch. 82; utilities, ch. 102.

State law reference(s)—Local Public Health Reorganization Act, V.T.C.A., Health and Safety Code § 121.001 et seq.; authority of home rule municipalities to enact health ordinances, V.T.C.A., Health and Safety Code § 341.081; local regulation of sanitation, V.T.C.A., Health and Safety Code ch. 342; food, drugs, alcohol and hazardous substances, V.T.C.A., Health and Safety Code ch. 431 et seq.; Texas Controlled Substances Act, V.T.C.A., Health and Safety Code § 481.001 et seq.; community services for mental health and mental retardation, V.T.C.A., Health and Safety Code § 534.001 et seq.; preservation of health in home rule municipality, V.T.C.A., Local Government Code § 54.004; nuisance in home rule municipality, V.T.C.A., Local Government Code § 217.042.

²Editor's note(s)—Ord. No. 2016-17, § 2, adopted July 12, 2016, amended article II in its entirety to read as herein set out. Former article II, §§ 42-31, 42-32, 42-56—42-72, pertained to similar subject matter, and derived from Ord. No. 69-05, §§ 1—3, 11-5-1969; Ord. No. 83-8, §§ 1—4, 11-2-1983; Ord. No. 93-15, § 15-1, 4-14-1993; Ord. No. 95-02, § 1(a), 2-8-1995; Ord. No. 2005-12, § 2, 9-14-2005; Ord. No. 2011-05, § 1, 9-27-2011.

1. For the purpose of consistency, should food trucks also be prohibited specifically from these locations in Sec. 42-64 (Food Truck Locations)

Sec. 42-31. Consumption of beverages or food in certain public places.

(a) *Prohibited areas of consumption.*

- (1) It shall be unlawful for any person to consume beverages or food on the streets, alleys, sidewalks, and parking areas in the area described in subsection (a)(2).
- (2) The prohibited area is that area the perimeter of which is the northern right-of-way boundary of First Street, the eastern right-of-way boundary of Front Street and the southern right-of-way boundary of Fourth Street, the western right-of-way boundary of Meyer Street, the northern right-of-way boundary of Main Street, the western right-of-way boundary of the alley in block 43, the southern right-of-way boundary of Second Street and the western right-of-way boundary of Meyer Street, as more particularly shown on Exhibit "A" attached to Ordinance No. 83-8 and incorporated in this section.

(b) *Non-prohibited areas of consumption.*

- (1) The provisions of this subsection do not prohibit the consumption of beverages and food inside establishments selling or offering food and beverages to the public.
- (2) The provisions of this section do not prohibit the consumption of beverages and food at events where the sponsors of the event obtain a permit from the city allowing the consumption of beverages and food at the event.

(c) *Punishment.* Any person who shall violate any of the provisions of this section shall be guilty of a misdemeanor and, upon conviction, shall be punished as provided in section 1-7.

(Ord. No. 2016-17, § 2, 7-12-2016)

Sec. 42-32. Milk and milk products.

- (a) *Adoption of state law.* The production, transportation, processing, handling, sampling, examination, grading, labeling and sale of all milk and milk products sold for the ultimate consumption within the city or its police jurisdiction; the inspection of dairy herds, dairy farms, and milk plants; the issuing and revocation of permits to milk producers, haulers and distributors shall be regulated in accordance with the provisions of state law and the Texas Specifications and Requirements, authorized under state law, and the applicable provisions of 1983 Public Health Service Grade A Pasteurized Milk Ordinance, certified copies of which shall be filed in the office of the appropriate official; however, Section 9 of the specifications and requirements shall be replaced by subsection (b).
- (b) *Grade requirements.* Only Grade A milk and milk products shall be sold to the final consumer, or to restaurants, soda fountains, grocery stores, or similar establishments; however, in an emergency the sale of pasteurized milk and milk products which have not been graded, or the grade of which is unknown, may be authorized by the health authority, in which case, such milk and milk products shall be labeled "ungraded."
- (c) *Punishment.* Any person who shall violate any of the provisions of this section shall be guilty of a misdemeanor and, upon conviction, shall be punished as provided in section 1-7.

(Ord. No. 2016-17, § 2, 7-12-2016)

State law reference(s)—Texas Milk Grading and Labeling Law, V.T.C.A., Health and Safety Code ch. 435; municipal regulation of milk, V.T.C.A., Health and Safety Code § 435.013.

Secs 42-33—42-55. Reserved.

DIVISION 2. SANITATION

2. Discussion regarding amendment to follow new State law (July 1, 2026):

Sec. 42-56. Definitions.

The following words, terms and phrases, when used in this division, shall have the meanings ascribed to them in this section, except where the context clearly indicates a different meaning.

City shall mean the City of Sealy, Texas.

Director shall mean the director of planning and community development or his/her designee.

Food shall mean any edible or potable substance prepared in accordance with the requirements of the regulatory authority.

Mobile food service establishment shall mean a food service establishment designed to be readily movable.

Nonprofit organization shall mean an organization that shows to the planning and community development department at the time of application a document issued by the state to indicate that such organization is a nonprofit organization for state sales tax purposes or for federal income tax purposes.

Permit shall mean a permit granted under authority of this division of the Code.

Person shall mean any individual, group of individuals, organization, firm, or corporation.

Regulatory authority shall mean the planning and community development department of the city.

Single service articles shall mean those articles that may not be reused for purpose of serving or eating food or beverages. Examples of single service articles include paper plates, paper cups, and plastic forks. This list is exemplary and shall not be construed to be exclusive of any other single service articles not mentioned herein.

Unit shall mean a mobile food service establishment.

Vendor shall mean a person or entity that has been granted a license under this division of the Code and shall include that person's or entity's officers and employees.

(Ord. No. 2016-17, § 2, 7-12-2016)

Cross reference(s)—Definitions generally, § 1-2.

3. Discussion regarding amendment to follow new State law (July 1, 2026):

Sec. 42-57. Area of jurisdiction.

- (a) *Applicability.* This division of the Code shall apply to all of the area within the corporate limits of the city.
- (b) *Nonprofit organizations.*
 - (1) Nonprofit organizations are not required to pay a permit fee under this division of the Code, but nonprofit organizations are required to obtain a permit and comply with all rules and regulations under this division.
 - (2) Nonprofit organizations are not required to comply with section 42-61, concerning certified personnel.
- (c) *Treatment of for-profit entities as nonprofit organizations.* A for-profit person or organization that is subject to this division of the Code shall be treated as a nonprofit organization under this division while such person or organization is temporarily employed, contracted, or engaged to provide food services to a nonprofit organization.

(Ord. No. 2016-17, § 2, 7-12-2016)

Sec. 42-58. Adoption of rules of state board of health.

The rules of the state board of health regarding food service sanitation, retail food store sanitation, and minimum standards of sanitation and health protection regulations of food establishment, including, specifically, 25 Texas Administrative Code, Chapter 229, Sections 161 through 171 and Sections 173 through 175, are adopted hereby and incorporated into this division by reference.

(Ord. No. 2016-17, § 2, 7-12-2016)

State law reference(s)—Health rules, V.T.C.A., Health and Safety Code §§ 341.002, 438.004; rulemaking authority, V.T.C.A., Health and Safety Code § 437.0056.

4. Discussion regarding amendment to follow new State law (July 1, 2026):

Sec. 42-59. Permits.

(a) *Permit required.*

- (1) It shall be unlawful for any person to operate a mobile food service establishment within the city without a valid permit.
- (2) An application for a permit shall be made in written form to the director.
- (3) Permits for mobile food service establishments shall only be available under the terms of this division.
- (4) An application must include satisfactory proof by the applicant that the applicant has obtained all other necessary licenses or permits required by applicable state and city rules and regulations.
- (5) Any person or entity applying for a permit must submit plans to the city, showing the food preparation, storage, and sales areas. The city shall not approve such plans unless the plans are in compliance with this division.
- (6) Any person or entity applying for a permit must submit written proof of access to and use of an approved water source and approved waste disposal site by means of a commissary letter or letter of permission from an approved servicing area, and a list of foods and beverages to be served on the unit, stating the source of the foods and beverages and when and where the foods and beverages will be prepared.
- (7) All mobile food service establishments and required attendant facilities shall be inspected by the regulatory authority prior to the issuance of a permit.

(b) *Acceptance and acknowledgement.* Acceptance of a permit is an express acknowledgement and consent to the terms and restrictions set by the regulatory authority. The use of a permit is a privilege, not a right, subject to reasonable restrictions as established herein or as may be promulgated by the regulatory authority.

(c) *Transfer of permit prohibited.* It shall be unlawful to attempt to sell, lease, or otherwise transfer a permit from the original permittee to any other person or entity, natural or unnatural. Such action shall result in automatic revocation of the permit, and the parties involved shall be prohibited from operating any such unit within the city limits for one year from the date of revocation. Such revocation shall not preclude any other legal action.

(Ord. No. 2016-17, § 2, 7-12-2016)

5. Discussion regarding amendment to follow new State law (July 1, 2026):

Sec. 42-60. Denial, suspension, or revocation of permits.

- (a) *Authority to deny, suspend, or revoke permit.* The city may deny, suspend, or revoke a permit to operate an establishment under this division if the applicant or holder does not comply with the requirements of this division, or if the operation of the establishment does not comply with the requirements of this division, or if the operation of the establishment constitutes a potential hazard to the public health.
- (b) *Delivery of notice of denial, suspension, or revocation of permit.* A permit shall be denied, suspended, or revoked by delivery of a notice to the applicant or holder of the permit. The notice shall give the applicant or holder of the permit the reasons for denial, suspension, or revocation. A delivery of the notice may be accomplished by personally delivering it the notice to the applicant or permit holder, by mailing a copy of the notice to the applicant or permit holder at the address indicated on the permit application, or by leaving a copy of the notice with an adult working at the establishment.
- (c) *Request for hearing on denial, suspension, or revocation of permit.* The applicant or holder of the permit may request a hearing on the permit denial, suspension, or revocation by filing a request for hearing with the planning and community development department of the city, in writing, within ten days following the receipt of the notice, such period to begin on the day following the receipt of the notice of denial, suspension, or revocation. If no request for hearing is received by the planning and community development department within the allotted time, the denial, suspension, or revocation is sustained.
- (d) *Hearing on denial, suspension, or revocation of permit.* If a timely request for hearing is received by the planning and community development department, a hearing will be conducted by the city, during which the applicant or holder may present evidence to show why the permit should not be denied, suspended, or revoked. Based upon the evidence of such hearing, the city shall make a final decision and shall uphold, suspend, modify or rescind any notice or order considered in the hearing. A written report on the healing decision shall be furnished to the applicant or the holder of the permit by the hearing officer.
- (e) *Lifting of suspension.* In a case where a permit is suspended, the suspension will be lifted only when the permit holder has abated all the defects which originally gave rise to the suspension. Failure to correct the defects within the time period given by the city or to request a hearing in writing to the regulatory authority within ten days of the receipt of suspension notice shall be sufficient cause for the suspension to become a final revocation of the permit.
- (f) *Application for new permit after revocation.* Whenever a denial or revocation of a permit has become final, the applicant or holder of the revoked permit may make written application for a new permit. The applicant or holder of the revoked permit must meet all rules and requirements as stated in this division before a new permit will be issued.

(Ord. No. 2016-17, § 2, 7-12-2016)

Sec. 42-61. Certified personnel.

At all times, in any establishment subject to this division, other than a nonprofit organization, the owner of the establishment shall be a state certified manager or shall employ an employee who is a state certified manager

and has successfully completed a course offered by or approved by the state or the state board of health covering the regulations adopted by this division.

(Ord. No. 2016-17, § 2, 7-12-2016)

6. Discussion regarding amendment to follow new State law (July 1, 2026):

Sec. 42-62. Permit fees.

- (a) *Assessment of fee and length of permit.* After inspection and approval by the director, each unit shall be assessed a permit fee. Permits shall be valid for 12 months from the date of issuance.
- (b) *Issuance of permit.* Permits shall be issued in accordance with the application procedures and upon payment of the permit fees, per unit, in accordance with the fee schedule adopted by city council.
- (c) *Renewal of permit.* Permits shall be renewed upon payment of the permit fee, submission to the planning and community development department of written proof of access to and use of an approved water source, and approved waste disposal site by means of a commissary letter or a permission letter from an approved servicing area, and re-inspection.

(Ord. No. 2016-17, § 2, 7-12-2016)

7. Discussion regarding amendment to follow new State law (July 1, 2026):

Sec. 42-63. Refund of permit fee.

Fees under this division are not refundable under any circumstances.

(Ord. No. 2016-17, § 2, 7-12-2016)

8. Discussion regarding Council's consideration of amending authorized and prohibited locations, with consideration of adding Sec. 42-31 criteria in this section:

Sec. 42-64. Locations.

- (a) *Length of time at a location.* Units may not be permanently parked overnight in one location. A unit may go to each location before the start of each day of business. The unit may be at one location or at multiple locations in one day. A unit may stay at one location on a daily basis as long as the unit is moved by 10:00 p.m. and does not stay overnight.
- (b) *Quantity of stops at one location per day.* A unit shall stop no more than three times every 12 hours at a particular location, except that a unit may stop at an establishment that is open 24 hours a day no more than six times in one day.
- (c) *Prohibited locations.* Units may not be located in whole or in part upon any public sidewalk, public park, public property, or public right-of-way without written permission.
- (d) *Locating on private property.* Units may not be located in whole or in part upon private property without written permission submitted to the director from the owner of the property upon which location the sales are to take place.
- (e) *Sales prohibited in residential areas and near school property.* No sale or offering to sell shall be made from any mobile food service establishment of any edible or potable substance on any property which is used or zoned for residential purposes, or within 500 feet of any public or private school property.

(Ord. No. 2016-17, § 2, 7-12-2016)

Sec. 42-65. Single service articles required.

Mobile food service establishments shall provide only single service articles for use by the consumers.

(Ord. No. 2016-17, § 2, 7-12-2016)

Sec. 42-66. Mobile food service establishment food source and food protection.

- (a) *Source.* Food shall be obtained from an approved commissary or a permanent food service establishment with a valid permit.
- (b) *Labeling.* Foods offered for sale shall comply with labeling laws where applicable.
- (c) *Condition of food.* Food shall be in sound condition, free of spoilage, filth, or any other contamination, and shall be safe for human consumption.
- (d) *Potable water.* Only potable water stored according to law shall be served. Ice shall be made from potable water. Fresh water shall be from a permitted commissary or approved servicing unit.
- (e) *Food storage.*
 - (1) Containers of food shall be stored at least six inches above the floor in a manner that protects food from splash and contamination and permits easy cleaning of the floor.
 - (2) No food, including packaged foods, shall be stored in contact with water or undrained ice.
 - (3) Conveniently located refrigeration facilities or effectively insulated facilities shall be provided to maintain potentially hazardous food at 41 degrees Fahrenheit (five degrees Celsius) or below.

- (4) Each refrigerator shall have an accurate thermometer.
- (5) Stored frozen foods shall be kept at a temperature of zero degrees Fahrenheit (-18 degrees Celsius) or lower.
- (6) Ice used for cooling stored foods, food containers, or food utensils shall not be used for human consumption.
- (7) Conveniently located hot storage facilities shall be provided to assure that potentially hazardous foods that are kept hot are maintained at 140 degrees Fahrenheit (60 degrees Celsius) or higher.
- (8) Each hot storage unit must have an accurate thermometer available.
- (f) *Thermometer for checking internal food temperature.* A product, or stem type thermometer, shall be used to check internal temperatures of potentially hazardous foods.
- (g) *Proximity of live animals.* Live animals, with the exception of service animals, shall be excluded from the surrounding areas of all mobile food establishments.

(Ord. No. 2016-17, § 2, 7-12-2016)

Sec. 42-67. Mobile food service establishment food specifications.

- (a) Each unit shall have a supply of paper towels, soap, and detergent, which shall be conveniently accessible.
- (b) Separate space shall be set aside from areas where food is served or prepared, for nonfood related items.
- (c) . Each unit shall have a stainless steel sink with a minimum of two compartments with adequate amounts of hot and cold water under pressure. Each unit shall also have adequate drain board space.
- (d) Each unit shall have an accessible and convenient hand-washing sink with hot and cold running water under pressure.
- (e) Each unit shall have hot water at a temperature of at least 110 degrees Fahrenheit (44 degrees Celsius) while the unit is in operation.
- (f) Fresh water must be provided in a self-contained system within the unit.
- (g) All water inlets shall be capped when not in use.
- (h) Wastewater must be disposed of at a permitted commissary containing an approved servicing area or a separate, approved servicing area. Wastewater shall be stored in a permanently installed retention tank that is sized at least 15 percent larger in capacity than the water supply tank and is sloped to a drain. The drain pipe shall be at least one inch or greater in inner diameter and equipped with a shut-off valve.
- (i) Toilet facilities, or the ability to secure nearby toilet facilities, are not required by the owner of the food truck.
- (j) Each unit shall provide and have available for the public, a fly-proof, lidded trash container for the disposal of refuse.
- (k) Each unit employing butane or propane tanks shall comply with any and all applicable fire department regulations. Each unit shall be equipped with an approved fire extinguisher with a 2A 10BC rating.
- (l) Each unit shall be maintained in good repair and kept free from material defects that may present a hazard to life or property.
- (m) Floors shall be constructed of smooth, easily cleanable materials such as ceramic tile, linoleum, or laminated wood. Sawdust, wood shavings, and peanut hulls are prohibited. Additionally, mats and duckboards shall be non-absorbent and cleaned daily.
- (n) Walls and ceilings shall be light colored, smooth, non-absorbent, and easily cleanable.

- (o) Construction studs and joist rafters shall not be exposed in food preparation or storage areas.
- (p) Food preparation areas shall have 50-foot candles of light.
- (q) All lights in food preparation areas shall be shielded.
- (r) Each unit shall have a ventilation system in good repair capable of removing steam, smoke, and grease-laden vapors from the unit.
- (s) Each unit shall be clearly marked with the phone number of the owner of the unit and the phone number of the city's planning and community development department. Additionally, each unit shall be readily identifiable by business name, printed in bold black letters not less than three inches in height, not less than one and one half inches in width, permanently affixed, and prominently displayed upon at least two sides of the unit.
- (t) Each unit shall conspicuously display the permit issued under this division at all times. In addition, each unit shall store on the premises at all times satisfactory proof or documentation detailing the origin or source of all foods being held, stored, offered for sale, sold, distributed or given away. Such records shall be available for review upon request.
- (u) Each unit shall maintain and display a current Texas motor vehicle license plate registration sticker.
- (v) The vendor shall not use the unit or permit anyone else to use the unit to sell, distribute, or give away any foods other than those specifically approved by the director, in writing, at the time the permit is issued. The vendor is not authorized to and shall not sell any nonfood items without the written consent of the director.

(Ord. No. 2016-17, § 2, 7-12-2016)

9. Discussion regarding amendment to follow new State law (July 1, 2026):

Sec. 42-68. Mobile food service establishment inspections.

- (a) Mobile food establishments shall be inspected a minimum of two times per year.
- (b) The owner of a mobile food service establishment shall keep the city's planning and community development department informed of the location of that mobile food service establishment.

(Ord. No. 2016-17, § 2, 7-12-2016)

Sec. 42-69. Promulgation.

The city's planning and community development department shall have the power, with the approval of the city council, to prescribe and promulgate such rules and regulations consistent with state law as may be deemed necessary to protect the health and safety of the public and to effectively perform its duties.

(Ord. No. 2016-17, § 2, 7-12-2016)

Sec. 42-70. Liability.

- (a) Except as otherwise provided by law, neither the city nor any officer, employee, agent, attorney, or contractor of the city shall be liable to any person in any capacity for any act, omission, or condition in any way directly or indirectly related to any provision of this division.
- (b) Any suit brought against any officer or employee of the city because of any act, omission, or condition in any way directly or indirectly related to any provision of this division shall be defended by legal counsel of the city to the extent not prohibited by law.

(Ord. No. 2016-17, § 2, 7-12-2016)

10. Discussion regarding amendment to follow new State law (July 1, 2026):

Sec. 42-71. Duties and powers of inspector.

- (a) The planning and community development department of the city shall serve as the health department of the city until such time as a separate health department is established.
- (b) The city shall designate a certified inspector within the health department.
- (c) The health department of the city shall enforce and administer this division and shall have all powers and authority reasonably necessary to discharge such duty, including but not limited to the following duties and concomitant powers:
 - (1) To enforce this division and to make appropriate recommendations to the city council on this division.
 - (2) To make inspections of all food service establishments from time to time as needed to determine compliance with this division. Such inspections are not limited to the inspections in connection with the issuance or renewal of a permit and may occur at other times to determine continued compliance with this division.
 - (3) To collect all fees set by the city council or provided by law.
 - (4) To make annual reports to the city council.
 - (5) To perform all other duties reasonably necessary to meet the requirements of this division.

(Ord. No. 2016-17, § 2, 7-12-2016)

Sec. 42-72. Criminal violations and penalties. (a)

- (a) A person commits a criminal offense if the person violates this division or a regulation adopted under this division.
- (b) It shall be an offense to interfere with any officer, agent, or employee of the city in the enforcement or administration of this division.
- (c) An offense under this division is punishable, upon conviction, as provided in section 1-7.

(d) The persons deemed criminally responsible for a violation shall include the owner of the business establishment, the person in charge of the business establishment, and each employee or worker violating this division.

(Ord. No. 2016-17, § 2, 7-12-2016)

Secs. 42-73—42-90. Reserved.

UPCOMING WEBSITE UPDATE, PENDING FEEDBACK FROM CITY COUNCIL REGARDING ANY AND ALL CHANGES TO CHAPTER 42:Re

Mobile Food Vendors

HB 2844 Implementation Materials

Mobile Food Vendors - Important State Law Changes Effective July 1, 2026

House Bill 2844 (89th Texas Legislature) establishes a statewide, uniform regulatory framework for mobile food vendors in Texas. The legislation creates a new occupational licensing program administered by the Texas Department of State Health Services (DSHS) and is intended to standardize regulation, reduce local inconsistencies, and support small food-based businesses.

The Act generally takes effect July 1, 2026, with limited provisions effective earlier to allow for rulemaking and implementation.

What is Changing?

- Beginning July 1, 2026, mobile food vendors must hold a state-issued license from the Texas Department of State Health Services (DSHS).
- The City of Sealy will no longer issue local permits for mobile food vendors after this date.

What Does NOT Change?

The City of Sealy will continue to regulate:

- Approved operating locations
- Fire and life safety requirements
- Traffic, noise and public safety regulations
- Compliance with local ordinances unrelated to food safety permitting

What Vendors Need to Do

- Monitor DSHS announcements regarding license applications and fees.

- Apply for a state mobile food vendor license prior to July 1, 2026.
- Continue to comply with ALL City of Sealy location and safety regulations.

Key Dates

- **May 1, 2026** - State rules adopted
- **July 1, 2026** - State license required

Frequently Asked Questions - Mobile Food Vendors

Q: What is HB 2844?

A: HB 2844 is a state law that creates a uniform licensing system for mobile food vendors across Texas, replacing local health permits with a state-issued license.

Q: When does the law take effect?

A: The law is fully effective on July 1, 2026.

Q: Will I still need a City of Sealy permit?

A: You will no longer need a City-issued permit, but you must still comply with City regulations related to fire safety and approved operating locations.

Q: Who issues the new license?

A: The Texas Department of State Health Services (DSHS). For more information on this process, you may visit their website: <https://www.dshs.texas.gov/>

Q: Can the City of Sealy still inspect food trucks?

A: Food safety inspections will be handled by the State. The City may still conduct inspections related to fire, safety, and ordinance compliance.

Q: Will this allow me to operate anywhere in Sealy?

A: No. State licensure does not override local parking or location restrictions.

Q: Where can I get more information?

A: Information will be posted as rules are adopted by DSHS.

ITEM #6



AGENDA ITEM NO:

Discussion and Presentation regarding Regulation of Low-Powered Vehicles (E-Bikes, Scooters, Golf Carts, etc.)

SUBMITTED BY: Russell Grimes

MEETING DATE: March 3rd, 2026

STAFF REPORT

DESCRIPTION

Background

In **January 2025**, City Council identified the **creation of a Scooter Safety Ordinance** as a policy priority following discussion regarding:

- Scooters operating in roadways
- Riders running stop signs
- Lack of sidewalks in parts of the city
- Safety concerns related to electric bicycles
- Questions regarding registration and safety requirements

The Creation of an Ordinance did not receive a majority vote of the Council. Instead, Council requested the Police Department to post Public Awareness of Use in compliance with State Traffic Laws. The discussion summary was included in the **March 4, 2025 Council packet**.

On February 18, 2026, a councilmember requested to revisit the topic due to the increased use of electric-powered vehicles since Council's last discussion.

As of the most recent codification update (Ordinance No. 2025-14, adopted May 6, 2025):

- The City of Sealy has **no specific ordinance** regulating:
 - Electric bicycles
 - Motor-assisted scooters
 - Neighborhood electric vehicles (NEVs)
 - Helmet requirements
 - Scooter rentals

Enforcement currently defaults to the **Texas Transportation Code**.

Current Legal Framework (State Law Controls)

Under Texas law:

- **Bicycles and E-Bikes** must obey traffic laws (Ch. 545 & 551).
- **Cities may NOT prohibit e-bikes** from highways primarily used by motor vehicles (Ch. 664).
- **Motor-assisted scooters** may operate on roads \leq 35 mph and may be restricted by cities.
- **Golf carts** may operate on \leq 35 mph roads only if authorized by local ordinance.
- No statewide helmet mandate exists.

NOTE: Texas Transportation Code § 541.302 "Highway or Street": "Highway or street" means the width between the boundary lines of a publicly maintained way, any part of which is open to the public for vehicular travel.

Current City Code

Sec. 98-8 (Bicycles; Skateboards; Skates – prohibiting use or parking of same on sidewalks or esplanades in any business or commercial area which is known as the downtown area) does not address:

- E-bike classifications
- Scooters
- Helmet requirements
- Operational restrictions

This section may be expanded, provided it does not conflict with state preemption.

Sec. 98-10 (Golf carts) regulation.

Policy Considerations

Council may legally:

- ✓ Expand Sec. 98-8 to include low-powered vehicles (ex. expand areas of use or prohibited areas and other regulations within local government authority)
- ✓ Clarify application of state traffic laws
- ✓ Restrict or prohibit scooters on sidewalks
- ✓ Establish helmet requirements for minors
- ✓ Implement public education measures

Council may NOT:

- ✗ Prohibit e-bikes from highways primarily used by motor vehicles
- ✗ Override state classifications
- ✗ Require registration inconsistent with state law

Vehicle Type	Texas State Law	Current Sealy Ordinance	Proposed City Regulation (If Directed)
Bicycle	Must obey traffic laws; lighting & brake required	Addressed generally in Sec. 98-8	Clarify applicability of Ch. 545 & 551
Electric Bicycle (Class 1-3)	Cannot be prohibited from highways primarily used by motor vehicles	Not addressed	Clarify allowed roadway use; regulate sidewalk operation if desired
Motor-Assisted Scooter	Allowed on roads ≤ 35 mph; city may restrict	Not addressed	Prohibit or restrict sidewalk use; adopt operational rules
Scooter Rentals	No direct statewide regulation for local rental programs	Not addressed	Permit/registration requirements for rental companies
Golf Cart	Allowed ≤ 35 mph roads if city authorizes	Addressed in Sec. 98-10	No proposed amendments to the ordinance
NEV	Must be registered, insured, inspected; ≤ 35 mph roads	Not addressed	Clarify allowed roadways consistent with state law
Helmet Requirement	Not required statewide	Not required	Optional helmet requirement for minors
Registration Requirement	No registration for bikes/e-bikes/scooters	None	Cannot conflict with state law

Key Legal Boundary

Texas Transportation Code Chapter 664 prohibits cities from banning e-bikes from motor-vehicle highways.

Local authority is strongest regarding:

- Sidewalk restrictions
- Operational safety measures
- Rental program regulation

RECOMMENDATION

Staff recommends Council provide direction on whether to:

1. Amend Sec. 98-8 to incorporate low-powered vehicles;
2. Adopt operational safety standards consistent with state law; or
3. Maintain enforcement under existing state law without local expansion.

ATTACHMENTS:

1. March 4, 2025 - Council discussion documentation regarding creation of a scooter safety ordinance
2. City of Sealy Code Sec. 98-8
3. City of Sealy Code Sec. 98-10

This is the result of the Council priority discussion in January 2025 regarding creation of a scooter safety ordinance and creation of a scooter rental ordinance. This information was presented in Council's packet on March 4, 2025:

CITY COUNCIL'S PROJECT/LEGAL PRIORITIES IDENTIFIED BY INDIVIDUAL VOTE FOLLOWING PRESENTATION/DISCUSSION: JANUARY 7, 2025

ITEM	LERMA	NOACK	MILLER	CURRY	ZAPALAC	BURTSHELL	MAYOR
14. Creation of Scooter Safety Ordinance	Remove from list	Put on hold	Remove from list, Need to follow roadway laws recommended by PD	Yes	Yes	Remove from list	Yes
<p>DISCUSSION: Curry stated this is a safety issue and we don't have sidewalks but Mike said a lot of cities won't let you ride them on sidewalks. Mike has seen them ride in the middle of the road. Chief said they follow the vehicle traffic regulations, stop at stop signs, etc. Not required to register. Can get a citation for running a stop sign. Burtshell: Do any cities require registration? Safety courses? Zapalac witnessed a dangerous situation in the Whataburger drive thru and expressed safety concerns. Curry concerned regarding electric bicycles. Zapalac reminded skateboards aren't allowed (on sidewalks). City Manager recommended Public Awareness of the laws associated with scooter use. Mike said we will be applying for a grant to install sidewalks and will need to look at sidewalk laws.</p>							
15. Creation of Scooter Rental Ordinance	Remove from list	Put on hold	Put on hold.	Put on hold.	Put on hold	Remove from list	Yes
<p>DISCUSSION: See above.</p>							

Council requested that SPD post public awareness regarding electric scooter traffic laws on their Facebook page.

Sec. 98-8. - Bicycles; skateboards; skates.

- (a) No person shall operate or ride upon any bicycle, skateboard, roller skates or street skates on any sidewalk, or esplanade in any business or commercial area of the city which is known as the downtown area.
- (b) No person shall park any bicycle or skateboard on any sidewalk or esplanade in any business or commercial area of the city which is known as the downtown area unless the area is designated as a bicycle or skateboard parking area.
- (c) Any person violating this section shall be punished as provided in section 1-7.
- (d) In addition to the penal remedy contained in subsection (c) of this section, the city attorney may, in appropriate cases, institute any proper legal action or proceeding, including action for injunction, to prevent, restrain, correct or abate any act, conduct, work, business practice or use which is a violation and, therefore, illegal under this section.

(Ord. No. 94-12, §§ 2, 3, 8-10-1994)

Sec. 98-10. - Golf carts.

- (a) Except as provided herein, a golf cart may be operated on all or part of a highway that is in the corporate boundaries of the city and has a posted speed limit of not more than 35 miles per hour. For safety reasons, a golf cart may not be operated on Highway 36 (Meyer Street), except as allowed in subsection (l) below. For purposes of this section, golf cart means a motor vehicle designed by the manufacturer primarily for use on a golf course. For purposes of this section, highway means the width between the boundary lines of a publicly maintained way any part of which is open to the public for vehicular travel.
- (b) Except for a golf cart operated exclusively in a master planned community, as defined by the Texas Transportation Code, as amended, a golf cart shall have a clearly visible license plate affixed to it.
- (c) A golf cart shall be equipped with the following minimum equipment as mandated by the Texas Transportation Code, as amended. All safety equipment shall be maintained as provided by the Texas Transportation Code:
 - (1) Operational headlamps;
 - (2) Operational tail lamps;
 - (3) Reflectors;
 - (4) Operational parking brake;
 - (5) Mirrors; and
 - (6) A Slow moving vehicle emblem for a golf cart that is operated at a speed of not more than 25 miles per hour when it is operated on a highway which such emblem being a reflective surface designed to be clearly visible in daylight or at night from the light of standard headlamps at a distance of at least 500 feet and shall be mounted base down on the rear of the vehicle at a height that does not impair the visibility of the emblem and shall be maintained in a clean reflective condition.
- (d) A golf cart operator shall be licensed to operate a motor vehicle as provided by the Texas Transportation Code, as amended, and carry a valid driver's license.
- (e) A golf cart operator shall maintain financial responsibility as required for other passenger vehicles in accordance with the Texas Transportation Code, as amended.
- (f) A golf cart operator shall abide by all traffic regulations applicable to vehicular traffic when using the authorized streets and parking areas of the city.
- (g) A golf cart shall not be operated or parked on a sidewalk, sidewalk area, or hike and bike trail except on a permanent or authorized temporary driveway.
- (h) Golf carts are prohibited from pulling trailers, boats, jet skis, other objects or people on public streets and the right-of-way.

- (i) The number of occupants in a golf cart shall be limited to the number of persons for whom seating is installed and provided on the golf cart.
- (j) All golf cart passengers shall be seated at all times while the golf cart is in motion and no part of the body of the operator or occupant shall extend outside the perimeter of the golf cart.
- (k) The operator shall not permit any occupant of the golf cart to ride in the lap of any occupant while the golf cart is in motion.
- (l) A golf cart may cross a highway at an intersection, including an intersection with a highway that has a posted speed limit of more than 35 miles per hour, except a golf cart may only cross Highway 36 (Meyer Street), regardless of the speed limit, at an intersection controlled by a lighted traffic control signal.

(Ord. No. 2023-31, § 2, 11-8-2023)

ITEM #7
REPORTS OR REQUESTS
FROM THE CITY
MANAGER AND
DISCUSSION

**ITEM #8
REPORTS,
ANNOUNCEMENTS, OR
REQUESTS FROM
COUNCILMEMBERS**

J. ADJOURN