



EDGECOMBE COUNTY

PLANNING & INSPECTIONS

Information Needed for Mobile Home Permits

- Preliminary Zoning Certificate:** This document must be completed by the Edgecombe County Planning Department for properties not located in any Town Limits or ETJ, with the exception of Leggett and Speed, prior to receipt of the septic report or improvements permit. If the property is located within a town or in a town's ETJ please obtain the preliminary zoning certificate from that jurisdiction.
- Septic Report or Improvements Permit:** The Environmental Health Department (Room 443) must give approval of all septic systems prior to any permits being issued. A copy of the septic system report is required before a mobile home permit is issued. If public sewer is used, this document will not be needed.
- Moving Permit:** If the home is being moved *within* Edgecombe County, a moving permit must be obtained from the Edgecombe County Tax Collector's office before a mobile home permit is issued. If the home is being moved *from another County* documentation from that County's tax office must be submitted as verification that no taxes are owed.
- Tax Assessor's Certification:** This document must be completed by the Edgecombe County Tax Assessor's (Room 312) and Tax Collector's (Room 154) offices. Tax Departments may request the title of the home.
- Bill of Sale or Title:** This document verifies ownership of the mobile home.
- Set up Contractor Form:** This document *must* be completed and signed by the setup contactor or the dealership.
- Zoning Certificate:** The Edgecombe County Planning Department (Room 205) will provide a zoning certificate for all property not located in any Town Limits or ETJ, with the exception of Leggett and Speed. If you are moving to a town or a town's ETJ, please obtain the zoning certificate from that jurisdiction prior to applying for permits.

Please present all of the applicable documents with your permit application to the Edgecombe County Planning & Inspections Department. Permits are issued between 8:00 a.m. and 4:00 p.m., Monday – Friday in Room 205. Payment is accepted by cash, check, credit card or debit card. No over the phone credit card or debit card payments will be accepted.

EDGECOMBE COUNTY PLANNING & INSPECTIONS

P.O. BOX 10, 201 St. Andrew Street

Tarboro, NC 27886

Phone: 252-641-7802 Email: Inspectionpermits@edgcombeco.com

Manufactured Home Building Permit Application

Application Date: _____ Tax Parcel ID#: _____

Applicant: _____ Phone #: _____

Homeowner (as shown on title/bill of sale): _____ Phone #: _____

Address: _____ City: _____ State: _____ Zip: _____

Person to live in Home: _____ Phone #: _____

Land Owner's Name: _____ Phone #: _____

Value of Home: _____ Size of Home: _____ Year of Home: _____

Power Company: _____ Premise or Account #: _____

Dealer/Sales Co. & License #: _____ Phone #: _____

Address: _____

Set-up Contractor/Mover & License #: _____ Phone #: _____

Address: _____

Electrician & License #: _____ Phone #: _____

Address: _____

A/C Installer & License #: _____ Phone #: _____

Address: _____

Plumber & License #: _____ Phone #: _____

Address: _____

Underpinning? Brick <input type="checkbox"/> Vinyl <input type="checkbox"/>	Permit Fees: Singlewide: \$ 125.00 Doublewide: \$ 165.00 Triplewide: \$ 190.00 Modular: \$ 250.00
Well <input type="checkbox"/> County Water <input type="checkbox"/>	
Has driveway been installed on property? Yes <input type="checkbox"/> No <input type="checkbox"/>	

I hereby certify that all information in this application is correct and will comply with the State Building Code and all other applicable State and local laws, ordinances and regulations. Work may only begin after approval and issuance of the permit. Failure to obtain a manufactured home permit will result in a Stop work Order and a \$200.00 fine will be assessed. Zoning Certificate may need to be purchased from the Town if the home is inside of a Town's Jurisdiction. Re-inspection fees are charged at \$75.00 first time or \$150.00 each additional trip.

Printed Name of Applicant/ Agent

Signature of Applicant/Agent

Date

Information for Set-up Contractor/MOVER or Dealership

Requirement for Edgecombe County Manufactured Home Building Permit Application

Contractor's Name & License #: _____ Phone #: _____

Contractor's Address: _____ City: _____ State: _____ Zip: _____

I propose to set-up a properly labeled manufactured home at the following address:

Address: _____ City: _____ State: _____ Zip: _____

I am a North Carolina licensed manufactured home set-up contractor/mover.

License #: _____ Name of Business: _____

Printed Name of Set-up Contractor/MOVER

Signature of Set-up Contractor /MOVER

Date

I am the owner of the proposed manufactured home. It is my intention to personally set-up the proposed manufactured home, and I understand that problems which may arise due to set-up of the home will be solely my responsibility, and I will be left with no recourse through the State or local jurisdiction and must assume total liability for correction of any problems that occur as a result of the set-up of the manufactured home. I personally have a thorough knowledge of the requirements of the **CURRENT** State of North Carolina Regulations for Manufactured Homes that require me to set-up the home in accordance with the home manufacturer's installation manual for **NEW** manufactured homes and either the home manufacturer's installation instructions or the **CURRENT** State of North Carolina Regulations for Manufactured Homes for **USED** manufactured homes with regard to the set-up of my home.--

Printed Name of Owner

Signature of Owner

Date

NOTE: ONLY the CURRENT manufactured home manufacturer's installation instructions may be used for the installation of a NEW manufactured home. If the homeowner is acting as his or hers own set-up contractor as prescribed in Section 1.2.4 of the CURRENT State of North Carolina Regulations for Manufactured Homes and in all cases the license name and number of the set-up contractor shall appear on the permit.

EDGEcombe COUNTY ASSESSOR'S OFFICE
201 SAINT ANDREW ST., SUITE 312, TARBORO, NC 27886
MANUFACTURED HOME TAX CERTIFICATION APPLICATION

PLANNING RM 205

New owner name: _____
 New owner mailing address: _____
 New location address: _____ Lot Number _____
 Is the home located in a Mobile Home Park? ___Yes ___No If YES, list the name of the mobile home park: _____
 Parcel ID: _____
 Land owner's name if different than homeowner: _____

TAX ASSESSOR'S OFFICE RM 312

Listing for Tax year(s): _____ Purchase date: _____ Cost: _____ Year: _____
 Make: _____ Model: _____ Width: _____ Length: _____ VIN# _____
 Home purchased from a dealer? Yes ___ No _____
 Home purchased from a Financial Institution as: Repossessed ___ Used home ___
 Home purchased from individual? Yes ___ No ___ If YES, give name and address of prior owner: _____
 address: _____
 Home will be: Rental ___ Occupied by Owner ___ Held for Inventory ___
If home purchased from individual or financial institution (excluding homes from dealer lot), please answer the following:
 Address of the home at time of purchase if different from address above. Street _____
 City: _____ State: _____ County: _____
 Was the home moved to the current location before or after purchase? _____ Before ___ After ___
 Was a MOBILE HOME MOVING PERMIT obtained by you to move the home? _____ Yes ___ No ___
 If NO, please list the name of person to whom the MOVING PERMIT was issued: _____
 MOBILE HOME MOVERS Name and Address: _____
 Have ALL taxes for the current year and prior years been paid? Yes ___ No ___
 If NO, all prior years taxes must be paid before certification will be issued.
 Years owed _____ Amount owed _____ Acct # _____
 Has the title been updated with DMV? Yes ___ No ___
 Name shown on title: _____

This form must be completed, signed, dated, and returned to the Edgecombe County Tax Assessor's Office. Information not completed or any discrepancies in the information provided will delay the processing time for completing the Manufactured Home Certification form. If you are relocating the home you must provide the Edgecombe County Planning Office with a Mobile Home Moving permit.
Affirmation of homeowner: GS 105-310.-311. Under penalties prescribed by law, I hereby affirm that to the best of my knowledge and belief this listing, including any accompanying statements, is true and complete. **Social Security Number:** The disclosure of this number is voluntary. This is needed to establish the identification of individuals. The authority to require this number for the Administration of a tax is given by United States Code Title 42, Section 405©(2)©(i).
 Taxpayer Signature _____ Date _____
 Employer: _____ Phone: Work: _____ Home: _____
 Social Security No. _____

FAILURE TO SUBMIT THIS FORM WILL DELAY PERMITS

FORM: EDE.MH-1

EDGECOMBE COUNTY ASSESSOR'S OFFICE
201 SAINT ANDREW ST., SUITE 312, TARBORO, NC 27886
MANUFACTURED HOME TAX CERTIFICATION

TAX ACCESSOR'S OFFICE RM 312

**EDGECOMBE COUNTY ASSESSOR'S OFFICE CERTIFIES THAT THE
MANUFACTURED HOME LISTED ABOVE IS PROPERLY LISTED/REGISTERED WITH
OUR OFFICE.**

Certified by: _____ Date: _____

TAX COLLECTOR'S OFFICE RM 154

**EDGECOMBE COUNTY TAX COLLECTIONS OFFICE CERTIFIES ON THE
MANUFACTURED HOME LISTED ABOVE:**

THERE ARE NO TAXES DUE TO EDGECOMBE COUNTY.

ALL EDGECOMBE COUNTY PROPERTY TAXES HAVE BEEN PAID.

Certified by: _____ Date: _____

STEP SPECS FOR MOBILE HOME

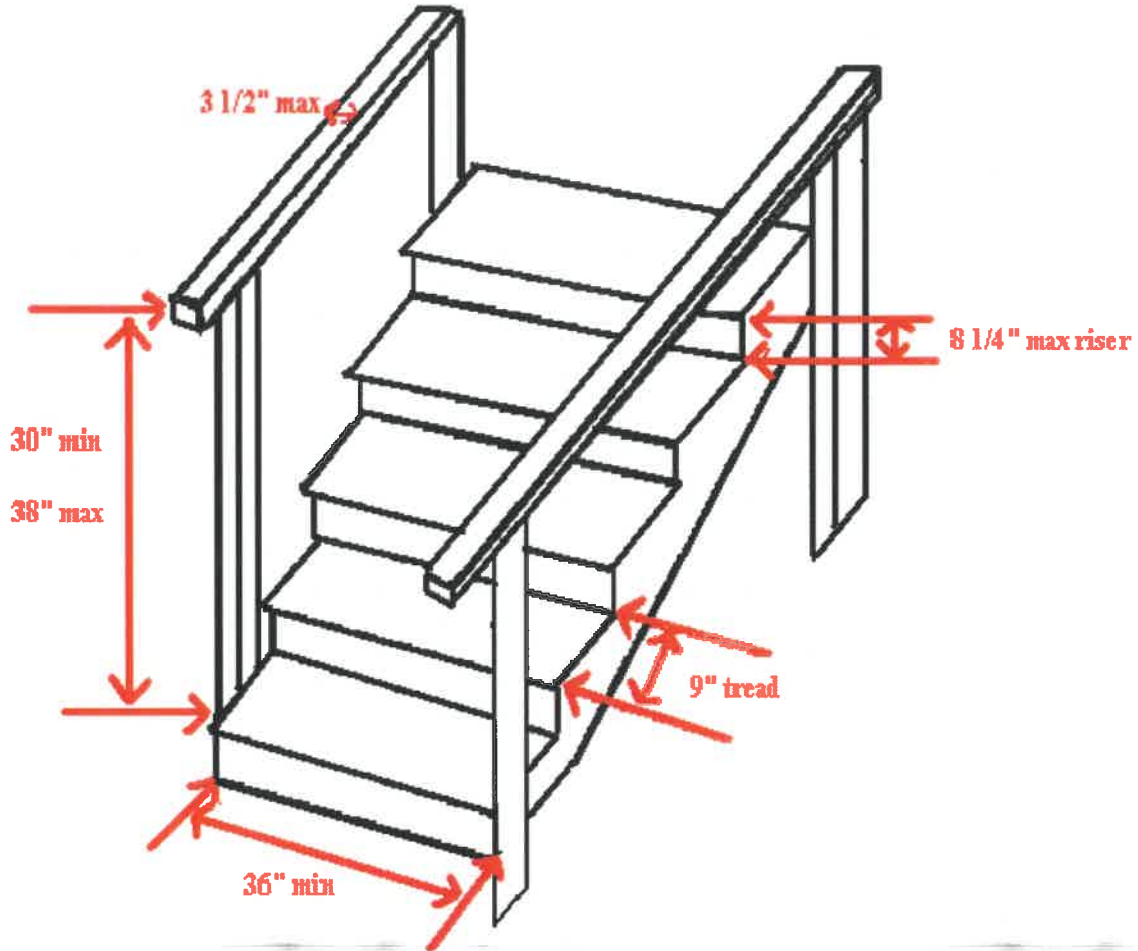

1. TO BE BUILT WITH TREAD LUMBER ONLY
2. OVER THREE (3) STEPS HIGH REQUIRES HAND RAIL ON BOTH SIDES
3. TREADS TO BE 9 INCH MINIMUM
4. RISER TO BE 8 ¼ INCHES MAXIMUM
5. HANDRAIL TO BE 30 – 38 INCHES HIGH
6. THE STEP WIDTH SHOULD BE A MINIMUM OF 36 INCHES WIDE
7. TWO (2) HANDRAILS, 36 INCHES ABOVE TOP OF STEPS