



DuPage County Division of Transportation

421 N. County Farm Road
Wheaton, IL 60187-2553
630/407-6900 (Fax) 630/407-6901

Trench Backfill and Pavement Restoration Specifications/Requirements Within DuPage County Highway Rights-of-Way

NOTE: All construction shall be performed and materials specified/installed according to IDOT'S 'Standard Specifications for Road and Bridge Construction' (latest edition) and the 'Supplemental Specifications and Recurring Special Provisions' (latest edition) and DuPage County's specifications stated herein.

MATERIAL REQUIREMENTS:

TRENCH BACKFILL- Requirements are, as follows:

Below bituminous/concrete materials (pavement, sidewalk, curb/gutter, etc.):

Material options shall be as directed and/or approved by a representative of the DuPage County Division of Transportation, as follows:

1. IDOT modified flowable Controlled Low-Strength Material (CLSM) (per IDOT's Standard Specifications Sec. 1019) for trench backfill method shall be installed full depth over the pipe capping material up to the base of the existing pavement cross-section. Only "Fly Ash" or "Flash Fill" material CLSM shall be utilized (per the attached DPC DOT standard). CLSM for installation below pavement shall be constructed per the following proportioning:

Mix 1	
Portland Cement	50 lb. (30 kg)
Fly Ash (Class C or F)	F= 300 lbs. (178 kg) / C= 125 lbs. (74 kg.)
Fine Aggregate (Saturated Surface Dry)	2900 lbs. (1720 kg)
Water	46-65 gallons (204.6 - 295.5 liters)

All materials shall meet the requirements of Section 1010.03 of IDOT'S Standard Specifications for Materials for: Portland Cement, Fly Ash, Fine Aggregate and Water. The County representative shall observe the flow-ability of the mixture and the water content adjusted within the specified limits to produce the desired results.

2. Full depth FA-6 or FA-7 (sand) shall be installed and compacted from the bedding materials (spring-line of the pipe) up to 6" below the existing pavement base. 6" Type B aggregate (CA-6) shall be installed and compacted up to the existing pavement base.
3. Full depth CA-7 (3/4" limestone chip, no fines) installed and compacted from the bedding materials (spring-line of the pipe) up to the existing pavement base.

Outside of bituminous/concrete materials (parkways, etc.):

CA-6 (limestone) or FA-6 or FA-7 (sand) aggregate shall be installed and compacted from the bedding materials (spring-line of the pipe) up to a 1:1 cross slope from any existing curb/gutter, pavement, sidewalk, etc. (per the attached 'Non-paved Trench Backfill' standard).

TEMPORARY PAVEMENT PATCH SPECIFICATIONS - Between November 15 and April 15 (or until hot bituminous material is available), a temporary patch may be installed, with County approval, as follows:

1. Bituminous pavement
Install the Class PP P.C.C. (7.1 or 7.2 bag mix 'High-early' w/1% calcium chloride additive) base course per the *Standard Pavement Patch* specifications listed herein. Install a layer of 4 mm. plastic film over the base course and install 3" Class PV P.C.C. (7.1 or 7.2 bag mix 'High-early'). The 3" P.C.C. layer shall be removed and the permanent bituminous pavement installed according to the *Standard Pavement Patch* specifications listed herein as soon as conditions permit.



DuPage County Division of Transportation

421 N. County Farm Road
Wheaton, IL 60187-2553
630/407-6900 (Fax) 630/407-6901

Trench Backfill and Pavement Restoration Specifications/Requirements Within DuPage County Highway Right-of-Ways

MATERIAL REQUIREMENTS (cont'd.):

TEMPORARY PAVEMENT PATCH SPECIFICATIONS (cont'd.) –

2. P.C.C. pavement

Install full depth Class PP P.C.C. (7.1 or 7.2 bag mix 'High-early' w/1% calcium chloride additive) to match the existing full depth pavement cross-section. #4 straight rebar shall be installed at 18" o.c. according to IDOT's Highway Standard #606001-02 into the existing pavement adjacent to the cut. Rebar shall not be installed into existing or within replaced curb/gutter

NOTE: The temporary patches above must be installed level with the existing pavement. Any grade elevation of more than 1/8" above the existing pavement may cause possible damage to snow plow equipment and/or the surrounding pavement.

STANDARD PAVEMENT PATCH- a 1' wide x 3" depth shelf shall be cut and pavement removed/replaced over the undisturbed pavement outside the limits of the cut. Install full depth (from base of existing pavement to 3" below finished surface) Class PP P.C.C. [7.1 or 7.2 bag mix 'High-early' (w/1-2% calcium chloride additive between 12/1 and 3/30)]. Saw-cut all edges of pavement and install 18" reflective crack control fabric over all joints prior to bituminous material installation. Install a bituminous emulsion prime coat and 3" HMA surface course over the PCC base course. All saw-cut joints shall be sealed with hot or cold crack filler.

CONSTRUCTION RESTRICTIONS AND REQUIREMENTS:

1. The use of temporary cold patch material (UPM) shall be permitted between November 15 and April 15 ONLY. The temporary cold patch shall be placed for a maximum period of 72 hours prior to the temporary and/or permanent pavement patching according to the specifications listed previously.
2. **THE USE OF STEEL PLATES IN OPEN LANES OF TRAFFIC IS STRICTLY PROHIBITED ON DUPAGE COUNTY DIVISION OF TRANSPORTATION ROADWAY PAVEMENTS NOVEMBER 15 THROUGH MAY 15.** LANE CLOSURES WITH TRAFFIC CONTROL SHALL BE MAINTAINED AT ALL TIMES FOR USE OF STEEL PLATES MAY 15 THROUGH NOVEMBER 15 (INCLUDING, BUT NOT LIMITED TO, 36" X 36" B/Y 'BUMP AHEAD' AND 'BUMP' WARNING SIGNAGE) UNTIL THE PLATE(S) IS/ARE REMOVED AND THE PERMANENT REPAIR IS COMPLETED.
3. Traffic control shall conform to the Manual for Uniform Traffic Control Devices and IDOT'S Highway Standards (including use of advance warning lane closure signage, an arrow board and Type I barricades w/sandbags) at ALL times for any lane closures on County rights-of-way. Flaggers shall be required to use 'Stop'/'Slow' paddles and flags and to wear reflective safety vests, as required. Advance warning "BUMP" signage shall be posted for the temporary patches, as required.
4. Saw-cut edges of pavement prior to final patching. Seal all joints with a cold or hot emulsion crack sealer.
5. The contractor, utility company or agency responsible for the necessary pavement open-cutting shall assume any and all liability and shall indemnify and hold harmless the County of DuPage, its successors and assigns, and its agents harmless for any injury to persons or damage to property due to the work.
6. The contractor, utility company or agency shall reimburse the County for any costs incurred by the County (including, but not limited to, restoration/replacement of pavement, curb/gutter, shoulders, walks, striping, signage, grading and/or installation of topsoil and seed or sod, labor and materials) or losses to equipment due to the work.



DuPage County Division of Transportation

421 N. County Farm Road
Wheaton, IL 60187-2553
630/407-6900 (Fax) 630/407-6901

Trench Backfill and Pavement Restoration Specifications/Requirements

Within DuPage County Highway Right-of-Ways

CONSTRUCTION RESTRICTIONS AND REQUIREMENTS (cont'd.):

7. All existing pavement striping, markings, symbols and reflective pavement markers (RPMs) damaged or removed due to the work shall be replaced in kind. RPMs shall be installed per IDOT's Highway Standards and DuPage County's specifications.
8. All materials and construction shall be installed and conform to IDOT'S "*Standard Specifications for Road and Bridge Construction*" (latest edition) and the "*Supplemental Recurring Special Provisions*" (latest edition), IDOT'S Highway Standards, AASHTO and DuPage County specifications. DuPage County shall have the final determination and give direction accordingly with regards to any conflicting specifications/requirements insofar as their jurisdiction entitles within the County rights-of-way.
9. The contractor, utility company or agency shall notify the Division of Transportation during normal business hours (8:00 a.m. to 4:30 p.m., Mon.-Fri.) of the required emergency repair(s)/pavement open cutting. Outside of these hours, contact the Sheriff's Dept. at 630/407-2400 to notify them of the lane restrictions and construction. Follow-up by notifying the Division of Transportation 630/407-6900 on the next business day of the construction performed.
10. Restoration to any disturbed areas of the right of way shall be dressed with a minimum of 6" topsoil and seeded (with erosion control blanket) or salt tolerant sod (staked in place) as directed by the Division of Transportation.
11. The contractor, utility company or agency shall contact this department a minimum of 48 hours prior to the start of construction to request a traffic signal locate. Traffic signals and related equipment are NOT on the J.U.L.I.E. system. Any costs incurred by the County for repairs due to damage to traffic signals/equipment due to the necessary pavement open cut(s) shall be the sole responsibility of the contractor, utility company or governing municipal agency or its assign.
12. Pavement, curb/gutter and storm structures shall be maintained free of mud/debris at all times during construction and shall be cleaned as directed by the County.
13. Erosion control shall be installed, maintained and construction procedures conform according to the minimum requirements of the DuPage County "*Countywide Stormwater And Floodplain Ordinance*" (latest revision) specifications at all times. Any questions regarding the ordinance should be directed to the DuPage County Stormwater Division in the Department of Economic Development and Planning Office at 630/407-6700 (M-F 8 am to 4:30 pm, excluding holidays).
14. Failure to comply with any of the specifications and/or construction restrictions and requirements listed herein shall cause the permit to become null and void as determined by the County Engineer, or his duly authorized assign.
15. Approval to perform the necessary repair/construction is given only insofar as the DuPage County Division of Transportation has jurisdiction and does not release the utility company or agency, and/or its agent and/or its contractor, from complying with existing local, county, township, state and/or federal statutes.

If you have any questions with regards to the specifications contained herein, please call the Division of Transportation Permitting Division at 63/407-6900 (M-F 8 am to 4:30 pm, excluding holidays).

DUPAGE COUNTY DIVISION OF TRANSPORTATION
TRENCH BACKFILL STANDARD IN NON-PAVED AREAS
(PARKWAYS, ETC.)

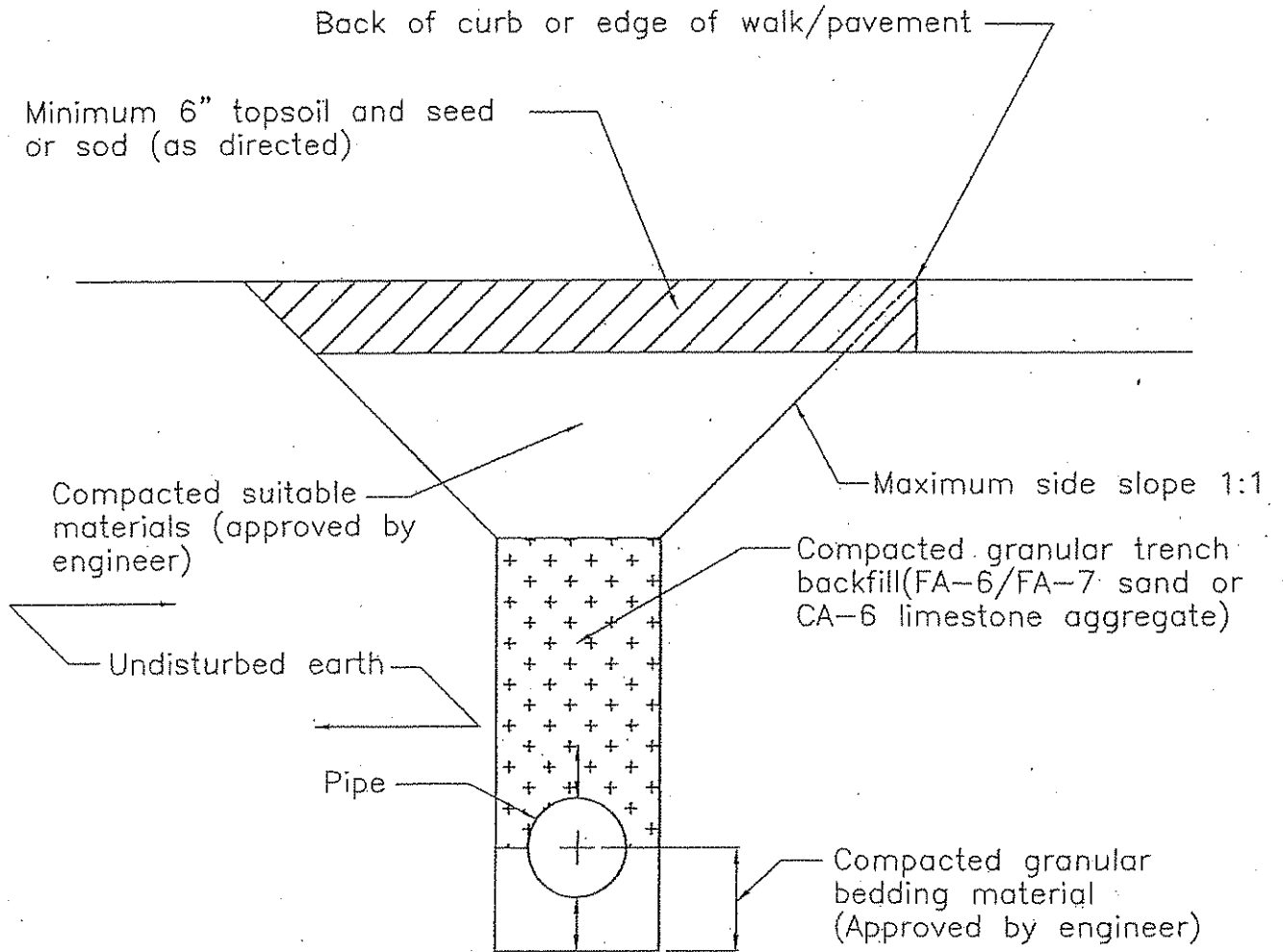

DUPAGE COUNTY DIVISION OF TRANSPORTATION

TRENCH BACKFILL STANDARD IN PAVED AREAS

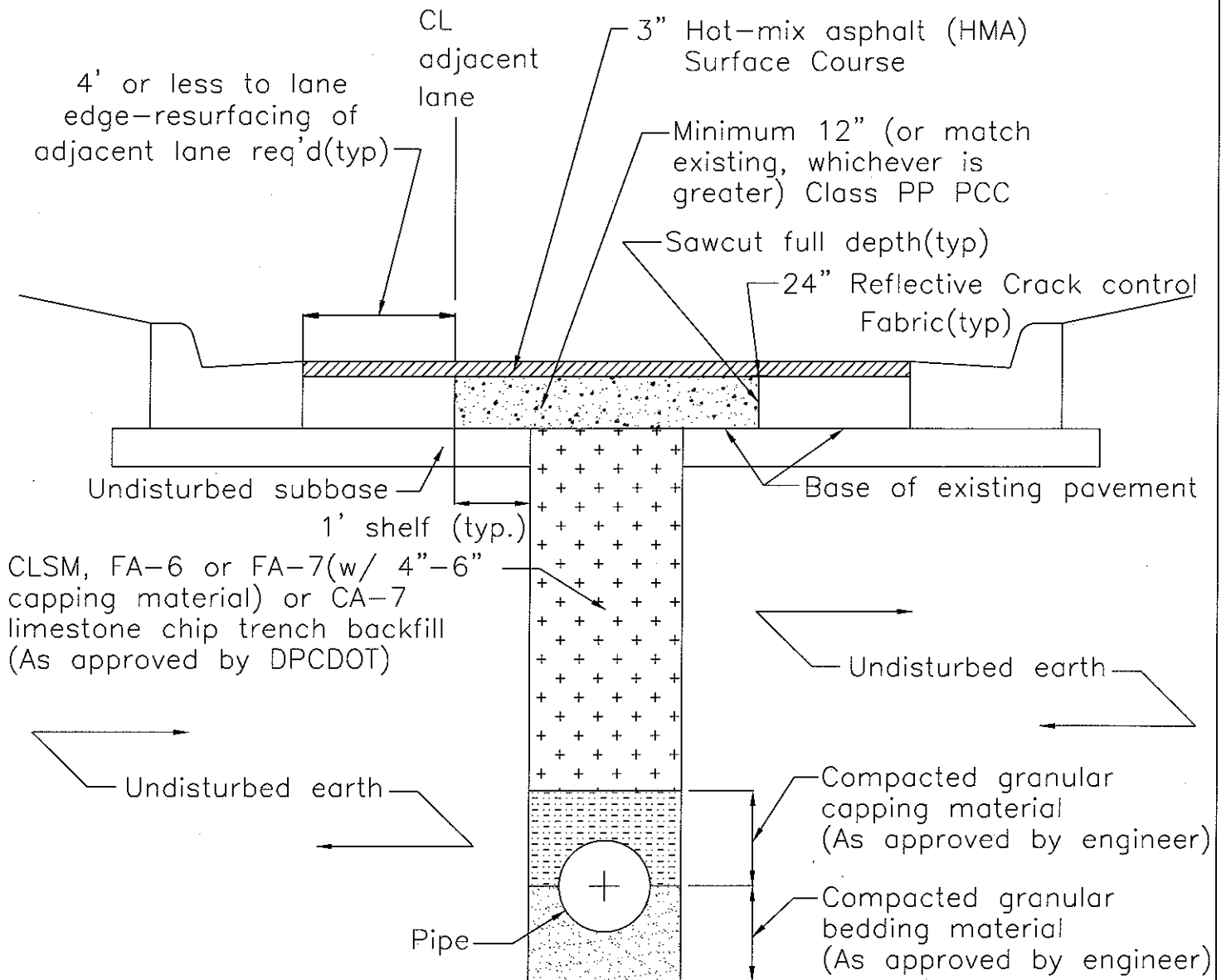

Notes:

1. All materials per IDOT's "Standard Specifications for Road & Bridge Construction" (latest edition) and "Supplemental Recurring Special Provisions" (latest edition).
2. Replace all pavement markings, striping, symbols and pavement markers in kind.