

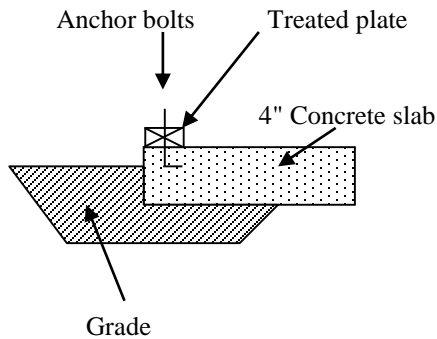

## **SHED INSTALLATION**

Shed/accessory building installations must meet the following requirements and is subject to all other zoning and building code requirements.



1. Before erecting a shed or accessory building, a permit must first be obtained from the Building Department.
2. Upon making application for a permit, a drawing and a plot plan must be provided. Wood or Metal sheds are acceptable.
3. The maximum height shall be eight (8) feet for a flat roof and eleven (11) feet for a gabled, hip, mansard or gambrel roof.
4. The floor area of accessory buildings shall not exceed one hundred twenty (120) square feet (10' X 12').
5. Not more than one accessory building, other than a private garage, shall be permitted on any residential lot.
6. All accessory buildings constructed shall have a four-inch thick concrete pad with wire mesh.
7. Accessory buildings must be secured to the concrete pad with anchor bolts.
8. All lumber within eight (8) inches of grade must be treated for exterior use.
9. The tool shed must meet all zoning regulations regarding location on rear property. Must be a minimum of six (6) feet from all property lines.