**SCHOOL ENVIRONMENTAL HEALTH
INSPECTION**

GUIDANCE DOCUMENT

Indoor Environments Section

Bureau of Environmental Health

Ohio Department of Health

246 N. High Street

Columbus, Ohio 43215

Forward

The Ohio Department of Health (ODH), Bureau of Environmental Health (BEH), Indoor Environments Section (IES) began the process of revising the school inspection manual in 2002 because many sanitarians from local health departments around the state expressed a desire for an updated, more comprehensive inspection manual to use while conducting the annual inspection of the school building and its environment. This manual is the culmination of years of research, meetings, drafts, edits, pilot programs and revisions.

In 2004, a survey was distributed to all local health departments regarding their school inspection program. The survey asked questions about the number of school inspections conducted each year, the length of time involved in school inspections, the importance of inspecting different items in the school environment and the equipment used to conduct the inspection. This survey was returned by 97 percent of all local health departments. Many of the respondents indicated a need for updated school inspection guidance.

The revision process began with staff from the ODH and local health departments meeting to discuss what the new school inspection manual should contain. The IES gathered information, prepared a comprehensive standard and drafted an inspection manual. The Ohio School Inspection Advisory Committee (OSIAC) was formed, comprised of representatives from:

- The Association of Ohio Health Commissioners
- Ohio School Boards Association
- Washington Township Fire Department
- General Health District of Cuyahoga County
- Highland County Health Department
- Marion County Health Department
- Delaware County General Health District
- Worthington City Schools Facilities Department
- The Ohio State University
- The American Lung Association of Ohio
- Ohio Bureau of Workers Compensation
- ODH

Prior to the first meeting of the OSIAC, staff from the ODH pilot tested the revised manual to evaluate it for ease of use, duration of inspections and opportunities for improvements.

The OSIAC began meeting in January 2005. The committee met monthly for a year and members' input was invaluable in the crafting of this manual.

When Jarod's Law was proposed and adopted through the efforts of Rep. Tom Raga, an additional advisory group was initiated to work on rule development. Organizations represented on this advisory committee include:

- The Association of Ohio Health Commissioners
- Auditor of State's Office
- Buckeye Association of School Administrators

- Jarod Bennett's Father
- Ohio Association of Boards of Health
- Ohio Association of Elementary School Administrators/Ohio Middle School Association
- Ohio Association of Independent Schools
- Ohio Association of School Business Officials
- Ohio Association of Secondary School Administrators
- ODH Bureau of Environmental Health
- Ohio Education Association
- Ohio Environmental Health Association
- Ohio Federation of Teachers
- Ohio School Boards Association
- Ohio School Facilities Commission
- Rep. Tom Raga's Office
- Warren County Board of Health

Jarod's Law (Ohio Administrative Code 3701-54-01 through 3701-54-09) became effective Sept. 27, 2007. In July, 2009, the House Bill 1 (Budget) repealed the Ohio Revised Code Sections 3701.93 through 3701.936 and amended ORC 4736.01 removing enforcement of Jarod's Law from the definition of Environmental Health practice and removing the authorization for the administrative rules. The statutory language reverted to the language prior to Jarod's Law which means local health districts are required to conduct sanitary school inspections semi-annually or twice per year.

Although, schools are required to be inspected twice per year, there are no rules or standards to which those inspections should adhere. Historically, ODH Bureau of Environmental Health provided guidance for the conduct of these inspections. ODH will continue to provide this information on its website as a reference to inform sanitary school inspections. Since Jarod's Law is no longer applicable, there is no legal requirement to use this guidance. Rather, the content of each school inspection will be determined by the local health department in whose jurisdiction the school is located.

ODH remains committed to assisting local health departments and schools in maintaining a healthy and safe school environment for all Ohio's children.

Introduction

Approximately 20 percent of the US population spends their day in a school building. In 1994, a Government Accounting Office report to the U.S. Congress indicated that 83 percent of Ohio's schools had at least one unsatisfactory environmental factor. Nearly half (48 percent) of schools reported problems with the HVAC systems in their buildings. The rate of childhood asthma has increased dramatically over the years to one out of 10 children. Poor Indoor Air Quality (IAQ) has a direct impact on persons with asthma resulting in more frequent asthma episodes. According to a 2004 report to the Under Secretary of the U.S. Department of Education, "The overall evidence strongly suggests that poor environments in schools, due primarily to effects of indoor pollutants, adversely influence the health, performance and attendance of students."¹

There has been much legislation passed since 1978 that has had a direct impact on school buildings, for instance, the banning of lead-based paint, prohibition on the use of asbestos containing products, clean water and clean air acts and the Americans with Disabilities Act.

While this manual is more comprehensive than the previous 1977 school inspection manual, it is not all inclusive. This manual is designed to give the local health department and school district officials a "snapshot" of the school environment at the time of the inspection. It is recommended that school systems have annual comprehensive school safety inspections as well. This safety inspection can be performed, upon request, by staff from the Public Employees Risk Reduction Program (PERRP) or by the Bureau of Workers' Compensation or by an independent safety inspector.

"Inadequate indoor environments in schools may decrease performance by causing health effects that either directly impair concentration or memory or indirectly affect learning."² Simply stated, students who are educated in buildings with fewer health and safety concerns perform better than students who are educated in buildings where a lack of maintenance has allowed the school building to deteriorate. School district officials are encouraged to use this manual to prepare for the local health department inspection, but should be aware there is much more than what is contained in this manual that school officials can and should do to maintain and improve their school facilities. The items in this manual constitute what ODH believes to be both important to the proper operation and maintenance of these environments and easily inspected by public health inspectors and school officials. School administrators are also advised the inspection performed by the local health department sanitarian is meant to address hazards in the school building that can be identified at the time of inspection. Remediation of all the problems indicated on an inspection report does not indicate the school is safe and free of all hazards throughout the school year.

ODH makes the following recommendations for sanitarians conducting inspections of school environments:

1. Use this manual in its entirety to conduct a health and safety inspection. The manual provides additional reference material on subjects that you might find helpful or that might be

¹ U.S. Department of Education, Office of the Under Secretary, *A Summary of Scientific Findings on Adverse Effects of Indoor Environments on Students' Health, Academic Performance and Attendance*, Washington, D.C., 2004.

² U.S. Department of Education, Office of the Under Secretary, *A Summary of Scientific Findings on Adverse Effects of Indoor Environments on Students' Health, Academic Performance and Attendance*, Washington, D.C., 2004.

helpful to schools. Inspection items can be broken into two inspections and completed during the two required inspections during a one year period. Inspections should be conducted while school is in session and building occupants are present so use of the building (from the perspective of health and safety) can be evaluated.

School personnel should be encouraged to plan for remediation of these items as they can be fit into the regular budget and maintenance plan for the school building.

2. Prior to conducting the health and safety inspection of the school building, it is recommended the sanitarian contact the school administrator to schedule the inspection. Doing so in advance will enable the school to assign a staff person to accompany the sanitarian and may reduce the amount of time at the end of the inspection in reviewing the identified hazards. It is recommended that when scheduling inspections, a sanitarian ask that a floor plan of the school be provided and that there be a representative, chosen by the school to accompany the sanitarian during the inspection. This representative should be able to provide access to areas of the school that may be restricted for building occupants (i.e., storage areas, roof, custodial closets, mechanical rooms, etc.). There is some concern that scheduling the inspection in advance will not reveal the true condition of the school. This is a valid concern; however, the benefits of working with the school staff in conducting the school health and safety inspection is of paramount importance for a healthy environment throughout the school year.

3. All specialty classrooms should be inspected at every inspection. Also, the sanitarian should inspect any areas of concern identified by the school. Our pilot inspections revealed that many issues found in general classrooms span across these classrooms. Therefore, ODH recommends that after completing an inspection of all specialty areas and classrooms, it is sufficient to inspect only 25 percent of remaining general classrooms.

4. Following inspection, meet with a school administrator or the facilities manager to review findings and answer any questions.

This manual contains sections regarding different areas of the school building and details hazards and recommended methods of correction or prevention for many inspection items. Some inspection items refer to structural components that, once inspected, may not need to be inspected again, unless the building undergoes renovation. During the development of this inspection manual, every effort was made to minimize the duplication of inspection duties between local health departments, code enforcement authorities and other qualified professionals. This was accomplished through the identification and omission of most inspection items currently mandated and regularly performed by other agencies and inspectors, such as local and state fire departments, local building departments, the Ohio Board of Building Standards, engineers and/or safety inspectors. Some items inspected by other agencies or inspectors were kept as part of this document because members of an advisory committee believed they posed a sufficient health hazard to warrant possible duplication of effort.

Please feel free to contact staff of the Indoor Environments Section at the Ohio Department of Health if you have any questions or concerns regarding the guidance for school environmental health and safety inspections.

Acronym List

ACBM – Asbestos-Containing Building Materials

ACMI – Art & Creative Materials Institute

AHERA – Asbestos Hazard Emergency Response Act

AHU – Air Handling Unit

ANSI – American National Standards Institute

ASHRAE – American Society of Heating, Refrigeration & Air-conditioning Engineers

ASTM – American Society for Testing and Materials

BWC – Bureau of Workers' Compensation

CDC – Centers for Disease Control and Prevention

CFR – Code of Federal Regulations

CPR – Cardio Pulmonary Resuscitation

CHP – Chemical Hygiene Plan

CO – Carbon monoxide

CO₂ – Carbon dioxide

CPSC – Consumer Product Safety Commission

CV – Constant Volume

ER – Emergency Room

GAO – Government Accounting Office

GFCI – Ground Fault Circuit Interrupter

HBSS – Hank's Balanced Salt Solution

HC – Hydrocarbon

HEPA – High Efficiency Particulate Air filtration

HVAC – Heating, Ventilation & Air Conditioning

IAQ – Indoor Air Quality

ICC – International Code Council

IICRC – Institute of Inspection, Cleaning and Restoration Certification

IPM – Integrated Pest Management

LCCA – Lead Contamination Control Act

MSDS – Material Safety Data Sheet

MMWR – Morbidity and Mortality Weekly Report

NFPA – National Fire Protection Association

NIOSH – National Institute for Occupational Safety and Health

OAC – Ohio Administrative Code

OBC – Ohio Building Code

ODH – Ohio Department of Health

OMC – Ohio Mechanical Code

ORC – Ohio Revised Code

OSHA – Occupational Safety and Health Administration

OSIAC – Ohio School Inspection Advisory Committee

PERRP – Public Employees Risk Reduction Program

PM – Particulate Matter

PPE – Personal Protective Equipment

PPB – Parts Per Billion

PPM – Parts Per Million

SDWA – Safe Drinking Water Act

ULSD – Ultra Low Sulfur Diesel

US EPA – United States Environmental Protection Agency

US FDA – United States Food and Drug Administration

UV - Ultraviolet

VAV – Variable Air Volume

VCT – Vinyl Composition Tile

VOC – Volatile Organic Compounds

Section 1 - Grounds & Building Exterior

1.1 ALL SCHOOL GROUNDS

1.1.1 *No trip hazards should be present and grounds should be maintained in a clean, orderly and sanitary condition with no litter*

Cracked or uneven sidewalks play areas, and other paved surfaces may pose significant slip, trip, and fall hazards leading to unnecessary accidents and injuries. All sidewalks and hard surface play areas should be level and free of excessive cracking to minimize hazard potential.

Trash and litter on the school grounds may attract unwanted pests. All litter should be picked up daily and placed into waste receptacles with lids to control pest infestations.

1.2 BUS & VEHICLE USE AREAS

INTRODUCTION

Every day millions of school children across America are exposed to variety of health and safety hazards posed by the school buses they rely on for their daily commutes. According to United States Environmental Protection Agency (USEPA), approximately 24 million children in the United States (US) ride in a school bus each day. The average time spent per student on a bus is more than 1.5 hours daily. More than 450,000 school buses are driven, on average, more than 4 billion miles per year.

In addition, children are inherently more vulnerable to many toxic environmental pollutants than adults.⁽²⁾ As such, a more conservative approach to minimizing childhood exposures to pollutants is warranted.

The majority of school buses in the US are powered by diesel engines that emit a variety of potentially hazardous air contaminants. School buses that are permitted to idle while on school property can pollute the air both in and around the bus. Exhaust from idling buses can also enter school buildings through air intakes, doors and open windows.



In addition to the health hazards posed by bus exhaust, school buses pose a variety of safety hazards to both passengers and pedestrians in their vicinity.

Section 1 – Grounds & Building Exterior

1.2.1 *Schools should abide by the engine idling time policies developed in accordance with rule 3301-83-20(O) of the Ohio Administrative Code* [This recommendation is based on accepted Standards but not required by law]

Rule 3301-83-20(O) states:

Districts should adopt engine idling time policies that minimize the amount of time diesel engines should be left idling. Diesel engine idling in excess of five minutes in school loading zones should not be permitted unless the operation of a wheelchair lift is required.

USEPA has determined that diesel exhaust is a likely human carcinogen. The soot and gases emitted by diesel buses are associated with other acute and chronic health effects including eye, throat and bronchial irritation; exacerbation of asthma and allergenic responses; and potential interference with proper lung growth and development in children.⁽¹⁾

Diesel exhaust contains significant levels of small particles, known as fine particulate material (PM). Fine PM is so small, several thousand particles can fit on the period at the end of this sentence.

Fine PM from diesel exhaust poses a significant health risk because it can pass through the nose and throat and become lodged deep in the lungs. This material can cause lung damage and premature death and may aggravate conditions such as asthma and bronchitis.

Additionally, idling buses waste fuel and money. Typical school bus engines burn about a half-gallon of fuel per hour of idling. School districts that eliminate unnecessary idling can save significantly in fuel costs each year.

School bus engines do not need to idle more than a few minutes to warm up. Extended idling actually causes engine damage. Engine manufacturers generally recommend no more than three to five minutes of idling. Caterpillar, Inc. cautions drivers to "... Avoid excess idling. If the vehicle is parked for more than five minutes, stop the engine. Excessive idling can cause carbon buildup and/or excessive idling can cause the engine to slobber. This is harmful to the engine." IC Corporation's engine manual states that "...Excessive idling reduces fuel economy and may decrease oil life." Cummins suggests idling for only three to five minutes before operating with a load.

Technologies to Minimize Idling

School buses can be retrofitted with equipment that reduces idling. While some of this equipment is standard or optional on new buses, older buses most likely will not have it.

After-market auxiliary heaters can be used to warm up engines and passenger compartments in colder climates. This equipment runs off the school bus fuel tank or off electric outlets and includes a timer that can be programmed to automatically start the heating function.

Overhead flashing lights and other safety equipment can be run by re-wiring the circuitry in the bus (some newer buses already have circuitry wired this way). The master switch for the overhead red flashing lights should be wired off the battery-positive side of the body solenoid (not the ignition side) so it will have power at all times, even with the key in the "off" position. The wire terminals from the overhead flashing lights unit should be connected so the complete

Section 1 – Grounds & Building Exterior

system works with the key off and the door open. Check with the manufacturer of the overhead unit for more information on re-wiring the circuitry.

Anti-idling Policies & Procedures

Idling-reduction policies and programs should, at a minimum, require the following:

As a general rule buses should be moving whenever the engine is on. The engine should be turned off as soon as possible after arriving at loading or unloading areas. The school bus should not be restarted until it is ready to depart.

Limit idling time during early morning warm up to comply with manufacturer recommendations (generally no more than five minutes).

During cold weather, provide a space in the school where bus drivers arriving early can wait while being protected from the weather.

Post signs in bus loading/unloading areas designating them as No-idle Zones. See examples below:



1.2.2 *No vehicles or gas-powered equipment should idle near outside air intakes, entrances or exits, or where buses are loading and unloading students*

Idling vehicles contribute to pollution in the outdoor and indoor environments. Emissions from vehicles can enter the school buildings through open windows and doors and through outside air intakes. Pollutants are then dispersed throughout the building and may cause students and teachers to develop headaches, fatigue and nausea. Exhaust from idling vehicles can also accumulate in student loading and unloading areas, posing a health risk to children, drivers and the community at large.

Section 1 – Grounds & Building Exterior**OTHER SMART PRACTICES FOR ENVIRONMENTALLY-FRIENDLY SCHOOL BUS OPERATIONS**

There are a number of important practices beyond idling policy that school administrators and fleet managers can institute to reduce school bus emissions and minimize exposure to diesel exhaust.

Reduce Emissions from Other Vehicles On or Near School Property

- Prohibit delivery trucks from idling on school grounds. Advise delivery services of the no-idling policy and consider posting signs in delivery areas.

Fleet Operation and Planning

- Assign the cleanest buses (fuel-wise) in the fleet to the longest routes.
- Inform drivers that following other diesel vehicles too closely can contribute to higher concentrations of diesel exhaust inside and outside the bus. Encourage bus drivers not to caravan.
- Arrange bus departure times so buses do not queue up for lengthy periods.
- Encourage children to sit in the front of the bus if the bus is not full.
- Examine the layout of the loading areas for each school. Re-configure to reduce queuing and idling.

Maintenance

- It is important that proper maintenance procedures, as suggested by engine and bus manufacturers, be followed for all school bus fleets. The National Association of State Directors of Pupil Transportation Services suggests: "...Like any motor vehicle, if quality and corrective engine and vehicle maintenance programs are conducted, school buses of any age will run cleaner."

Cleaner Fuels

- Use of alternative diesel fuels such as ultra low sulfur diesel (ULSD), biodiesel and emulsified diesel can lead to significant reductions in emissions of PM, CO, nitrogen oxides and sulfur oxides.

Bus Retrofit Technologies

- Diesel oxidation catalysts are devices that use a chemical process to break down pollutants in the exhaust stream into less harmful components.

Diesel Particulate Matter Filters

- Diesel PM filters are ceramic devices that collect PM in the exhaust stream. The combination of PM filters and ULSD fuels can reduce emissions of PM, HC and CO by 60 percent to 90 percent.

Section 1 – Grounds & Building Exterior

ECOLOGICAL IMPACT

- Diesel exhaust also contains pollutants that contribute to ozone formation, smog and acid rain.
- Fine particles from diesel engines contribute to haze which restricts our ability to see long distances.

1.3 SIDEWALKS & WALKWAYS***1.3.1 Vehicle use areas, including bus loading and unloading areas and pedestrian walkways should be clearly marked***

An average of 26 school-age children die in school transportation-related traffic crashes each year. Of those, 19 die as pedestrians.⁽⁴⁾ To ensure pedestrian safety, all walkways should be marked according to guidance provided in the Ohio Traffic Engineering Manual.⁴

Providing clearly marked parking areas will indicate proper locations for drivers to park their cars. No-parking/stopping areas should be designated near building entrances and exits and near outside air intakes, if cars are likely to idle. These areas should be clearly marked with *NO PARKING* signs and no-stopping or parking regulations should be enforced by school personnel.

Every year children are injured, sometimes fatally, when boarding or exiting a school bus. According to the National Highway Traffic Safety Administration, an average of 26 school-age children die in school transportation-related traffic incidents each year. Of these 26 deaths, 19 (roughly 73 percent) are pedestrians either boarding or exiting the vehicle.

Providing marked areas for school buses and other vehicles to load and unload students on school grounds will help to prevent some of these deaths.

In dual-use areas (recreation and loading/unloading areas), the Ohio School Facilities Commission recommends the use of different colored lines for vehicular parking stripes than those used for game striping.

1.4 GROUNDS ADJACENT TO BUILDING***1.4.1 All buildings should be in general good repair***

The proper design, construction, operation and maintenance of each exterior building system is essential to preserving the structural integrity, aesthetics, environmental health and safety of the building. The following sections provide deeper insight into (a) the core elements of an effective exterior building inspection; and (b) the underlying rationale for each.

1.4.2 There should be no evidence of standing water or evidence on the building of water damage or of conditions that may contribute to water intrusion into the building or that may contribute to mosquito breeding; gutters and drainage systems should be in good repair and maintained; windows and walls should show no sign of damage; there should be adequate drainage away from building foundation

Section 1 – Grounds & Building Exterior**Gutters and Downspouts**

Downspouts are designed to direct storm water collected by overhead gutters into storm water drains or directly to grade - provided adequate slope exists to effectively channel water away from the foundation. Unfortunately, all components comprising the storm water collection and drainage system may become clogged with leaves, sticks and other debris. Any obstruction in this system increases the likelihood of water overflow and seepage in the vicinity of the building foundation.

Storm drains, typically located on the ground immediately below each downspout and adjacent to the foundation, receive rain water collected from downspouts and then direct that water into below-grade storm sewers or away from the building. A poor connection between downspout and storm drain or drainage system may cause storm water to miss the drain and, instead, pour directly onto the ground adjacent to the foundation. Obstructions in the sewer system may lead to storm water backups and overflows at the storm drain. Both outcomes often result in foundation water issues.

Splash plates are generally manufactured concrete pads placed beneath downspouts where no storm drain exists. Because the amount of water directed onto these plates during stormy periods is so significant, it is imperative that they be installed with sufficient slope to prevent water accumulation near the foundation.

Improperly sloped or obstructed gutters and downspouts may cause rain water overflow, leading to uncontrolled ponding and seepage on the ground below. Should such spill-over occur in an area lacking adequate slope to effectively drain this water away from the building, seepage may occur at the foundation. Basement walls wetted in this manner become prime candidates for mold growth and structural degradation over time.

Finally, leaves, nests or other debris permitted to accumulate in gutters, downspouts or drains will invariably result in water accumulation and, over time, the decay of such debris. Standing water can also provide a favorable breeding ground for mosquitoes while the decaying plant material will harbor a variety of bacterial and fungal species. These pests and contaminants pose a health hazard to building occupants and maintenance workers.

Windows and Walls

Windows that are not properly maintained allow pests into the school building, make thermal comfort for the occupants more challenging, create safety issues and may expose students to contaminants released from deteriorated paint. Poorly maintained window systems also allow for water intrusion into the school environment. Water intrusion may lead to mold growth if not promptly corrected. Window panes that are cracked from one side of a window frame to the other side may come out of the frame more readily, causing injury to persons nearby.

Windows should be visually inspected on an annual basis to ensure there aren't any cracks in the panes and the joints are properly caulked. Any deteriorated paint on the window components should be repaired in a lead-safe manner to prevent students from becoming exposed to any lead dust or debris.

Windows that are cracked or not properly weatherized may collect condensation on the surfaces and/or allow water to intrude into the school environment. When moisture is allowed to collect

Section 1 – Grounds & Building Exterior

and remain, mold will start to grow. Mold growth is an indication that there is a problem with moisture. For sensitive individuals, mold exposure can result in an allergy or asthma episode.

Visible bowing of exterior walls may be a precursor to more serious structural defects that can eventually lead to wall failure. Because of the potentially life-threatening consequences of such failures, visible bowing of exterior walls should be evaluated by a registered professional engineer experienced in structural evaluation.

Bricks, mortar joints, siding and trim intact

Cracks and other openings in the exterior walls represent sites in the building envelope where moisture and pests may enter the building. Moisture penetrating the building envelope through such openings may soak through construction materials such as wood and drywall leading to mold growth and/or structural damage either within the wall cavity or in the building's interior. Such cracks should always be evaluated and monitored to determine their cause and to define a corrective/preventive course.

Cracks may occur in the mortar joints, bricks or in the other substrates comprising the exterior wall system. They are caused by the movement of wall elements most commonly due to either thermal expansion and contraction or settling. The amount of soot or dirt in a crack may be an effective indicator of the age of the crack. Clean cracks typically indicate recent movement, while cracks with significant soot deposition are likely old and possibly inactive.

Cracks due to contraction and expansion often vary with the season. They should be cleaned and sealed with a flexible sealant, because re-mortaring cyclical cracks will generally cause additional cracking. Cracks arising from foundation settling do not commonly vary with the seasons and may be re-mortared. Persistent masonry problems should be evaluated by a registered professional engineer. Cracks in wood siding may generally be sealed with a flexible caulking material.

Paint or Finish Intact

Peeling or cracking paint on the building exterior may be a sign of a humidity-control problem or improper paint application. Peeling exterior paint is often caused by moisture being absorbed through the back of masonry walls or wood siding which then passes through to the exterior surface under the paint. Paint subjected to these conditions eventually loses its adhesive properties and peels off. The interior of masonry walls should be properly vented to allow any moisture trapped inside the wall to escape. Additionally, building moisture sources and indoor humidity levels can be controlled through proper exhaust ventilation at high moisture sources such as restrooms, locker rooms and kitchens.

Drainage

The ground immediately adjacent to the building exterior should receive all of the water that impacts and cascades down the walls. During periods of heavy rain, this translates into hundreds of gallons of water pouring onto the ground at the wall-ground interface. Where the ground along this interface is insufficiently sloped to enable water to effectively drain away from the building, the potential for water migration through the foundation or basement walls is greatly increased.

Section 1 – Grounds & Building Exterior

Water accumulation or ponding near the building perimeter may be evidence of a drainage problem that could lead to water migration into the building. Because the concrete block composition of foundation walls are largely porous, water streaming below grade and down the exterior wall can actually migrate through the block itself and eventually moisten the interior wall surfaces. Once this occurs, porous materials in contact with the moistened block, such as wood studs, furring strips, paneling, insulation or drywall, become moistened as well, greatly increasing the probability of mold growth and structural degradation of these surfaces.

Although waterproofing materials and vapor barriers applied to both interior and exterior wall surfaces during construction may help to retard moisture migration through the wall cavity, they cannot completely seal these surfaces. This is especially true in cases of surface water intrusion, where the amount of water originating at the foundation due to poor site drainage is often excessive. As such, they should not be relied upon to prevent water migration through wall cavities.

Significant water ponding also constitutes a potential site for mosquito breeding. Mosquitoes go through four distinct stages during their life cycle:

Egg: hatches when exposed to water;

Larva: (plural. - larvae) "wiggler" lives in the water; molts several times; most species surface to breathe air;

Pupa: (plural - pupae) "tumbler" does not feed; stage just prior to emerging as adult;

Adult: flies short time after emerging and after its body parts have hardened

The first three stages occur in water, but the adult is an active flying insect that feeds upon the blood of humans and/or animals. The female mosquito lays the eggs directly on water or on moist substrates that may be flooded with water. The egg later hatches into the larva, the elongated aquatic stage most commonly observed as it swims in the water. The larva transforms into the pupa where internal changes occur and the adult mosquito takes form. After two days to a week in the pupal stage, the adult mosquito emerges onto the water's surface and flies away. By eliminating water ponding sites, we can effectively control mosquito infestations near the school building.

1.4.3 *There should be no accumulation of grass clippings or other organic debris immediately adjacent to the building foundation*

Grass clippings discharged close to and in the direction of the building may result in two primary concerns. First, the buildup of grass clippings on the outside air intake grilles servicing the building's air handling units (AHUs) may restrict or even "choke off" outside air supplied to those units. This could result in under-ventilated interior spaces. Second, the buildup of clippings at the exterior walls may create an ideal home for a variety of pests, especially insects, thereby increasing the likelihood of their entry into the structure.

Section 1 – Grounds & Building Exterior

1.5 OUTSIDE AIR INTAKES**1.5.1 *There should be no contaminant sources near outside air intakes and air intakes should be protected by screens, louvers or other filtering devices***

Air contaminant sources such as dumpsters, animal nests and idling vehicles proximate to outside air intakes may adversely affect IAQ when odors and emissions from those sources become entrained in the air stream entering the building. All such sources should be inspected and assessed to determine the likelihood of contaminant entrainment and to prevent entrainment of contaminants. Consideration should always be given to prevailing wind direction in performing the assessment.

Some diseases that are known to be transmitted from bird feces to humans are Cryptococcosis, Histoplasmosis, Salmonellosis. Birds build their nests in areas where their young will be protected, such as eaves of buildings or in rafters and attic spaces when accessible. Bird droppings are commonly found in large quantities around the nesting area. When bird droppings dry they can become aerosolized and inhaled. Bird droppings in close proximity to the outside air intakes of the school building can become entrained into the school's ventilation system and dispersed throughout the building. The exterior of the school building should be visually inspected on a regular basis and any areas that harbor bird nests should be altered in a manner that will prevent birds from roosting near outside air intakes. In some instances it is safer not to disturb the dried fecal matter so that persons are not exposed to any potential contaminants in the feces.

Trees and shrubbery that are allowed to grow next to the school building provide shelter for animals to build their nests. Examples of diseases that can be transmitted to humans from rodents are Hantavirus, lymphocytic choriomeningitis, and tularemia. These diseases are generally transmitted to humans when the excreta of rodents dries and becomes aerosolized. Because the diseases described are transmitted to humans through inhalation, it is important to routinely inspect the exterior of the school building to identify any animal nests.

Rabies is another disease that is transmitted to humans by animals such as bats, raccoons, skunks, dogs and cats to name a few. Rabies, however, does not live outside the body and is generally transmitted to humans through animal bites. During 2004 in Ohio, 4 percent of all bats tested were found to be positive for rabies. In comparison, none of the dogs tested were identified with rabies. To keep bats out of the school environment, access to the building should be prohibited. Holes larger than a quarter inch by half inch should be caulked or covered.

Avoid bat proofing the school in the summer when young bats can't fly and would be trapped inside the building. The best time of year to perform bat proofing in the school is in the fall and winter when bats leave to hibernate.

Insect nests that pose the greatest potential risk in the school environment are from the bee family. Some individuals are allergic to stings from bees, wasps and hornets. Allergic reactions can be life threatening.

Honey bees can build their nests in wall cavities as well as hollow trees. Removing a nest of bees inside a wall cavity can be more difficult than from a hollow tree. A professional bee-keeper should be employed to remove active bee nests. Wasp and hornet nests when identified should not be disturbed unless the location of the nests poses a hazard, e.g. in a classroom window. Remove the nests in the wintertime when wasp and hornet colonies die off.

Section 1 – Grounds & Building Exterior

1.5.2 *Outside air intake screens should be intact & unobstructed*

Outside air intakes should be protected from animal and insect entry via screens or grates. Screens or grates should be inspected regularly to prevent the accumulation of excessive debris which could severely restrict the flow of outside air to the occupied zones and to assure they remain in good condition.

1.5.3 *There should be no paint, roofing materials, or other sealants or coatings applied during occupied periods without the use of exposure control methods*

Vapors released from solvent-based construction materials may be both objectionable and hazardous to building occupants exposed to such materials. While contaminant pathways for vapors generated from construction materials applied indoors are generally obvious, vapors may also migrate inside from emission sources outside the building. Doors and windows kept open during warmer periods provide a clear pathway for such contaminants to enter the building. However, such problems may even occur during the winter months via the outside air intakes of AHUs proximate to the contaminant source. One common example of this involves the application of roofing tar upwind from rooftop AHUs whose outside air intakes are open.

While it is recommended that such activities not be conducted while the building is occupied, if they are, every precaution should be taken to protect building occupants. Such precautions may include the choice of low-emitting building materials or products and proper ventilation control (sectioning off, not shutting down building ventilation) or local control of contaminant generating activities. The school's Safety Plan should have outlined policies and procedures for any construction, renovation or repairs that occur while the building is occupied.

1.6 EXHAUST STACKS, VENTS & CHIMNEY FLUES

1.6.1 *Identify location of exhaust stacks, vents & chimney flues; exhaust stacks, vents & chimney flues should be unobstructed*

Effluent streams from chemical exhaust stacks, sanitary vents, chimney flues and kitchen exhausts may contain a wide range of potentially hazardous materials that may pose serious safety and health consequences to building occupants. These effluents may be flammable, explosive, toxic or highly irritating. Ideally, we would like to know the direction and concentration of these contaminant streams to determine the areas of highest threat. Unfortunately, the air flow patterns generated as air passes over buildings of even simple geometry are determined by a myriad of variables and, as such, are quite complex and difficult to predict. To prevent the unplanned re-entry of airborne contaminants back into the building - a phenomenon known as “re-entrainment” - exhaust stacks should be located as high and far from potential re-entry points as practical and should be designed such that their exhaust plumes do not discharge into the numerous recirculation zones and turbulent regions that exist adjacent to the building envelope.⁽¹⁾

You will find that there are no set-in-stone distances or heights for these vents. Ohio Building Code (OBC) has specific and detailed distances, but the building code changes, and buildings of various ages will be required to adhere to different standards. However, it is possible to assess if there are potential problems. Particularly if there have been complaints of odors or health symptoms from building occupants, it is important to identify what stacks vent what pollutants (chemical, kitchen, sanitary) and evaluate whether they're in close proximity to operable openings such as outside air intakes, windows or exits/entrances.

The following are general guidelines applicable to the proper assessment of rooftop exhaust stacks put forth by the American Conference of Governmental Industrial Hygienists (1998). These are more conservative than OBC, but should be considered when designing a building, assessing it for health/safety or when dealing with a concern of health complaints or odors. If there are currently no reports of odors or health symptoms, no action may be warranted, but stacks and intakes should still be identified by type in case there should be future problems. If problems are noted related to stacks and re-entrainment at the time of inspection or during a consultation, it is recommended that the school consult a certified industrial hygienist with a specialty in ventilation to accurately assess the issue and offer advice on remediation.

1.7 ROOF

1.7.1 *The roof of a school should be inspected by a qualified individual once a year following severe weather, as determined by the school and when otherwise deemed necessary.*

One aspect of maintenance that should not be neglected is the roof; adopting a proactive roof maintenance plan can save a lot of money and repairs down the road. Even a small leak can severely impact the inside of a building and drain productivity and budgets. Yearly roof cleaning and the application of roofing sealants will help prevent problems. Every roof should be periodically inspected to identify deficiencies. It is preferable to perform these inspections in the spring and fall each year. Individuals capable of determining not only apparent, immediate problems but also those conditions that could become problems, should perform these inspections.

Section 1 – Grounds & Building Exterior

Inspections conducted by school personnel or individuals hired for roof maintenance should include:

- Clearing debris from around drains.
- Making sure the outside perimeter and flashings are in good condition.
- Checking typical locations of stress for any tears or splits.
- Checking for a loosening of roofing material/flashing/caulking where the roof meets vertical surfaces or where mechanical units (HVAC equipment, etc.) are attached to the roof surface.
- Examining membrane seams that could possibly open up over time.
- Making sure there are no signs of deflection, which indicate a problem with the roof structure itself.

Once deficiencies have been identified, a qualified roofing mechanic should perform repairs in a timely manner.

A properly executed roof maintenance program should not only reduce leaks, thereby minimizing mold development, but as a secondary benefit, it should increase roof longevity.

If you suspect mold has infested a building material, a visual inspection is the most important step in identifying a possible mold contamination problem. The extent of water damage and mold growth should be visually assessed; all organic materials should be investigated.

If HVAC units are located on the roof, the assessment of the HVAC unit, as specified in section 6.13, should also be performed when the roof is inspected.

Severe weather means any weather event that could damage the roof or lead to water intrusion including, but not limited to, damaging wind, hail, lightning, ice damming or heavy rain.

REFERENCES

BUS AND VEHICLE USE

1. *Clean School Bus USA (Website)*. U.S. Environmental Protection Agency, <http://www.epa.gov> (9-9-04)
2. *Health Assessment Document for Diesel Engine Exhaust*. U.S. Environmental Protection Agency, Office of Research and Development, National Center for Environmental Assessment, Washington Office, Washington, DC, EPA/600/8-90/057F, 2002, (4-4-05)
3. *Traffic Safety Facts 2001 - School Transportation-Related Crashes*, U.S. Department of Transportation, National Highway Traffic Safety Administration, Document No. DOT HS 809 479. <http://www-nrd.nhtsa.dot.gov> (9-14-04)
4. *Ohio Traffic Engineering Manual*, Ohio Department of Transportation, <http://www.dot.state.oh.us> (4-7-05)
5. *School Bus Safety Rules*, National Safety Council, <http://www.nsc.org> (8-14-07)

Section 1 – Grounds & Building Exterior

EXTERIOR ENVIRONMENTS

6. *Guide to Protecting Children's Health in School (Website)*, U.S. Environmental Protection Agency. <http://www.epa.gov> (9-9-04)
7. *National Institute for Occupational Safety and Health (NIOSH) Safety Program Checklist for Schools*, Centers for Disease Control and Prevention, <http://www.cdc.gov/niosh/> (8-14-07)
8. *Designing and Building Healthy Places*, Centers for Disease Control and Prevention, <http://www.cdc.gov/healthyplaces/> (8-14-07)
9. *Healthy School Environments*, National Clearinghouse for Educational Facilities (NCEF), <http://www.edfacilities.org/index.cfm> (8-14-07)

Section 2 – Playgrounds

INTRODUCTION

Each year, many children receive emergency department care for injuries that occurred on the playground. According to the United States Consumer Product Safety Commission (CPSC), 76 percent of these injuries occur on public playgrounds. Approximately 15 percent of the injuries are severe and can result in hospitalization or death. The most prevalent injuries are fractures, which account for 39 percent of all injuries. According to a fact sheet by the American Academy of Orthopedic Surgeons, the estimated cost of playground equipment-related injuries, for individuals younger than age 20 was 11.1 billion dollars in 2001. The main cause of injury on playgrounds is falls to the surface, constituting 79 percent of all injuries.

From January 1990 through August 2000, 147 children died due to injury sustained on a playground. The main cause of these fatalities (38 percent) is strangulation due to entanglement on a piece of equipment. It is important to look for protrusion hazards on equipment that could entangle a child's clothing. In addition, bike helmets should never be worn while using playground equipment.

Another hazard not specifically listed in this document but the sanitarian should be aware of is tripping hazards. All anchoring devices for playground equipment, such as concrete footings or horizontal bars at the bottom of flexible climbers, should be installed below ground level, beneath the base of the protective surfacing material, to eliminate the hazard of tripping. This will also prevent children who may fall from sustaining additional injuries due to exposed footings. Low retaining walls are commonly used to help contain loose surfacing materials. In order to minimize trip hazards, retaining walls should be highly visible and any change of elevation should be obvious. The use of bright colors can contribute to better visibility.

Playgrounds and playground equipment may be designed for children at different developmental stages. Playgrounds that are designed for children that are preschool age have more restrictive requirements for fall hazard prevention devices such as guardrails, protective barriers and handrails. Playgrounds designed for older children should not be used by preschool children. It is important for the adults supervising the playground to know what the intended age of the user is for the playground being used. Therefore, it is important to have proper signage at the entrance to the playground equipment alerting adults as to which age group for which the playground has been designed.

The CDC states that we should devote resources to developing and using safer playground equipment and surfaces and to educating the public about playground safety issues. School playgrounds should comply with standards established by the CPSC and the American Society for Testing and Materials (ASTM). The inspection items listed in this manual represent the most common causes of injuries on playgrounds. An inspection conducted using this manual is not a comprehensive playground safety inspection. The inspection items were listed to assist the sanitarian in identifying the most serious of hazards found on a playground, based on recommendations found in the CPSC Handbook for Public Playground Safety, published November 1997. Whenever these hazards are identified, the sanitarian should make a recommendation to the school to have a certified playground safety inspector complete a comprehensive audit of the playground.⁶

Section 2 - Playgrounds

2.1 GENERAL SAFETY**2.1.1 *Students should not be allowed to use the playground during school hours without staff supervision***

All playgrounds present some challenges and children can be expected to use equipment in unintended and unanticipated ways; therefore, adult supervision is required at all times the playground is in use for school purposes. Supervisors should understand the basics of playground safety and be aware that playground equipment is designed based on the age-appropriateness of children who may use the playground.

2.1.2 *All playground equipment should be in good repair*

To minimize injuries, equipment should be kept in good repair. Wooden playground structures should have smooth surfaces to reduce splinters. Plastic structures should be smooth and intact and metal structures should not be rusted. It should be noted here, that playground equipment may pose a significant pathway for disease transmission during cold and flu season. It is a good idea to encourage hand washing both before and after use of the playground.

2.1.3 *Equipment components should not have any protruding bolts or separations that could cause the entanglement of a portion or portions of the body, clothing, jewelry, or other items that may result in the strangulation or dismemberment of the user.*

To minimize injuries, playground equipment should be in good repair. The surfaces of equipment can be a major determinant regarding the severity of potential injuries. It is therefore important that all bolts and/or separations should not protrude from the playground equipment in order to minimize injury to the user.

2.1.4 *The school should make available to the sanitarian, at the time of inspection, any and all reports from inspections done of the playground.*

Records of inspections and repairs should be maintained and made available to the sanitarian at time of inspection. Inspection records should include the manufacturer's maintenance instructions and checklists used. The person performing the inspection should sign and date the form used. A record of any accidents or injuries reported on the playground should also be kept and be made available upon request.

A comprehensive maintenance record should be developed prior to use of the playground. All equipment and grounds should be inspected frequently using proper documentation.

Section 2 - Playgrounds

2.2 PROTECTIVE SURFACING

2.2.1 *Surfacing in the use zones of playground equipment should be maintained according to the chart below:*

Table 1.1 **Maximum height (in feet) of equipment or of highest play surface based on minimum amount (in inches) of surfacing material present**

Material	Fall Height	Inches of Compressed Material
Wood Mulch (non-CCA)	7 feet	9 inches
Wood Chips	10 feet	9 inches
Sand	4 feet	9 inches
Pea Gravel	5 feet	9 inches
Shredded Rubber	10 feet	9 inches

When installing loose-fill material over a hard surface, in a manner consistent with protective surfacing material in a playground setting, the following conditions should be met:

- 1) immediately over that hard surface a three to six inch layer of drainage material should be installed,*
- 2) A layer of geotextile cloth should be placed on top of the drainage material,*
- 3) Loose fill material should be installed over the geotextile cloth that meets the requirements outlined in Table 1.1, and*
- 4) An impact attenuation mat should be installed in high traffic areas where loose fill material displacement is likely.*

According to CPSC, emergency room admissions data indicates that the most frequent playground injuries for children are a result of falls from equipment. The surface under and around playground equipment can be a major factor in determining the injury-causing potential of a fall. A fall onto a shock absorbing surface is less likely to cause a serious injury than a fall onto a hard surface. Hard surfacing materials, such as asphalt or concrete, are unsuitable for use under and around playground equipment of any height unless they are required as a base for a shock absorbing unitary material such as a rubber mat. In addition, playgrounds should also meet the accessibility requirements as outlined by the Americans with Disabilities Act. The surfacing material used should be approved and installed according to ASTM Standard F 1292 and F 1951 recommendations that are referenced in the chart below.

2.2.2 Surfacing other than those contained in 2.2.1 should provide a level of protection that is equivalent or superior to those listed in 2.2.1 and the levels of protection should be certified by an independent testing agency that meets the ASTM standards

2.3 SAFE USE ZONES

As stated from the paragraph above, the vast majority of injuries on public playgrounds occur from falls. The items listed below are designed to be easily identified by the registered sanitarian. When problems are noted during the inspection, a referral for a comprehensive playground audit by a certified playground safety inspector should be made to the school personnel. Correction of the following problems will assist in lowering the incidence in playground injuries.

Section 2 - Playgrounds

2.3.1 Use zones around slides, swings and stationary equipment should be free of obstructions and should be of the following dimensions

SLIDES: *At the front of the slide, the use zone for slides less than or equal to six feet should be at least six feet, for slides greater than six feet the use zone should be equal to the height of the slide (not required to exceed eight feet), and a six foot radius from all other parts of the slide.*

The use zone in front of the exit of a slide should extend a minimum distance of $H + 4$ feet where H is the vertical distance from the protective surface at the exit to the highest point of the chute (see Figure 1). However, no matter what the value of H is, the use zone should never be less than six feet, but does not need to be greater than 14 feet. The use zone should be measured from a point on the slide chute where the slope is less than 5° from the horizontal. If it cannot be determined where the slope is less than 5° from the horizontal, the use zone should be measured from the end of the chute. The use zone in front of the exit of a slide should never overlap the use zone of any other equipment.

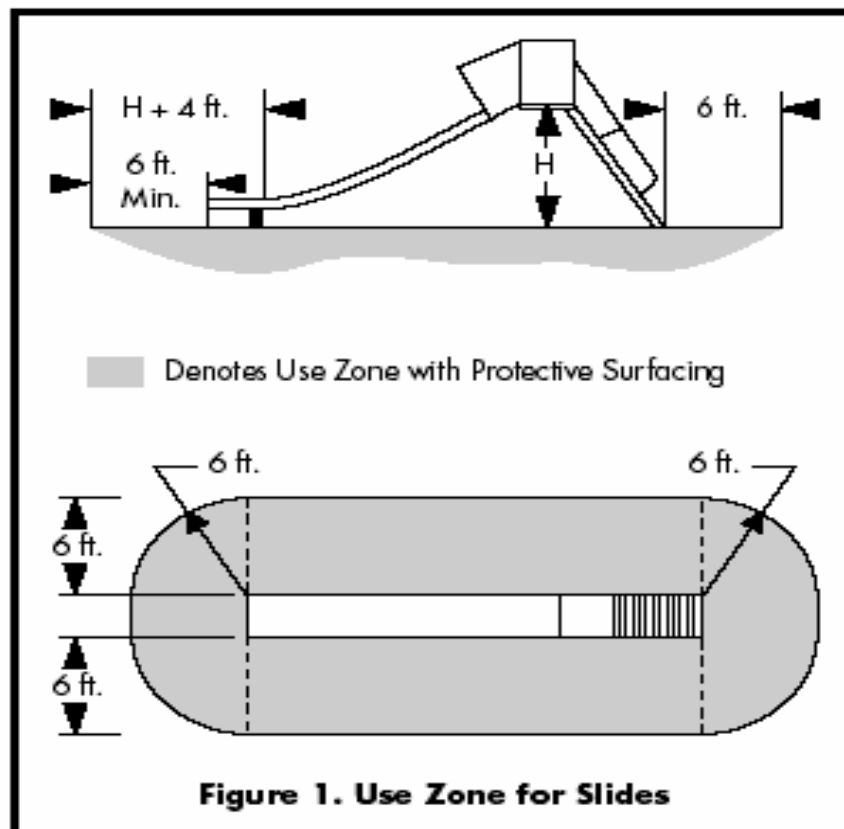

SWINGS: *Twice the height of the swings (from the surfacing material to the pivot point of the swing) in front and back and a six foot radius from the sides of the swing structure*

There are, generally, two types of swings: single-axis of motion and multiple-axis of motion. A single-axis swing is intended to swing back and forth in a single plane. A multiple-axis swing

Section 2 - Playgrounds

consists of a seat (generally a tire) suspended from a single pivot point that permits it to swing in any direction. Swings structures should be located away from other equipment or activities to help prevent children from inadvertently running into the path of a moving swing. Specific safety guidelines for different types of swings can be found in the reference documents cited in the overview of this section.

It is recommended that the use zone extend to the front and rear of a single-axis swing a minimum distance of twice the height of the pivot point above the surfacing material measured from a point directly beneath the pivot on the supporting structure (see figure below). The use zone to the sides of a single-axis swing should follow the general recommendation and extend a minimum of six feet from the perimeter of the swing structure in accordance with the general recommendation for use zones. This six foot zone may overlap that of an adjacent swing structure. The use zone to the front and rear of tot swings should extend a minimum distance of twice the height of the pivot point measured from a point directly beneath the pivot to the lowest point on the occupant seating surface when the swing is occupied. The use zone to the front and rear of single-axis swings should never overlap the use zone of any other equipment.

For a multi-axis swing, the use zone to the sides of a single-axis swing should follow the general recommendation and extend a minimum of six feet from the perimeter. The use zone should extend in any direction from a point directly beneath the pivot point for a minimum distance of six feet + the length of the suspending members (see Figure 3). This use zone should never overlap the use zone of any other equipment. In addition, the use zone should extend a minimum of six feet from the perimeter of the supporting structure.

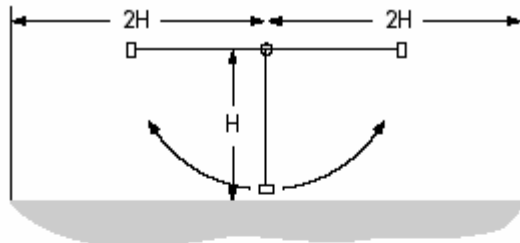

Denotes Use Zone with Protective Surfacing

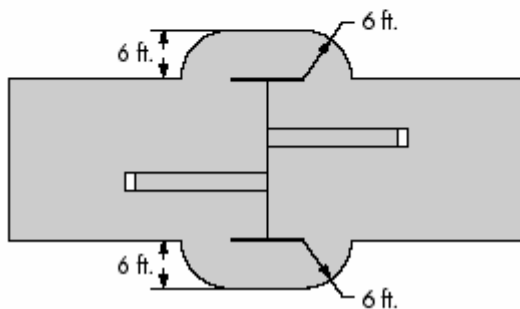

Single – Axis Swing

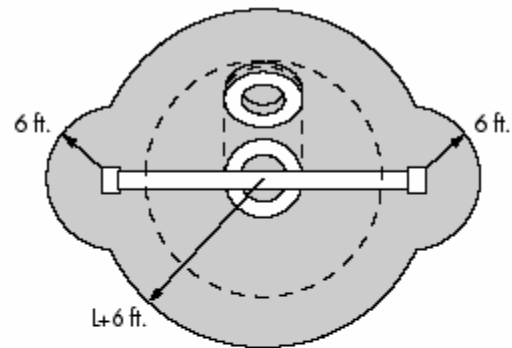

Denotes Use Zone with Protective Surfacing

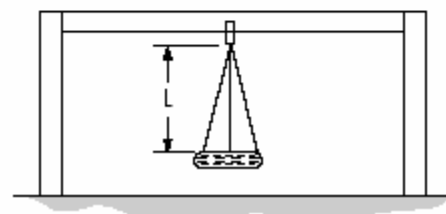

Multi-Axis Swing

STATIONARY EQUIPMENT: Six feet in all directions

Section 2 - Playgrounds

For stationary equipment, the use zone should extend a minimum of six feet in all directions from the perimeter of the equipment. The use zones of two stationary pieces of playground equipment that are positioned adjacent to one another may overlap if the adjacent designated play surfaces of each structure are no more than 30 inches above the protective surface (i.e., they may be located a minimum distance of six feet apart). If adjacent designated play surfaces on either structure exceed a height of 30 inches, the minimum distance between the structures should be nine feet.

2.4 SWING SAFETY

2.4.1 All "S" hooks should be closed

Open S-hooks can catch a child's clothing and present a strangulation hazard. S-hooks are often part of a swing's suspension system, either attaching the suspending elements to the overhead support bar or to the swing seat. S-hooks should be pinched closed. An S-hook is considered closed if there is no gap or space greater than 0.04 inches. It is appropriate to measure this gap with a feeler gauge but, in the absence of such a gauge, the gap should not admit a dime.

2.4.2 Swings not recommended for playground use should not be present on school grounds

The following types of swings are NOT recommended for use in public playgrounds:

Animal Figure Swings – These are not recommended because their rigid metal framework is heavy, presenting a risk of impact injury.

Multiple Occupancy Swings – With the exception of tire swings, swings that are intended for more than one user are not recommended because their greater mass, as compared to single occupancy swings, presents a risk of impact injury.

Rope Swings – Free swinging ropes that may fray or otherwise form a loop are not recommended because they present a potential strangulation hazard.

Swinging Dual Exercise Rings and Trapeze Bars – These are rings and trapeze bars on long chains that are generally considered to be items of athletic equipment and are not recommended for public playgrounds.

2.5 HEAD ENTRAPMENT

2.5.1 Equipment should not have any openings between three and one half inches and nine inches in size

A component or a group of components should not form openings that could trap a child's head. A child's head may become entrapped if the child enters an opening either feet first or head first. Head entrapment by head-first entry generally occurs when children place their heads through an opening in one orientation, turn their heads to a different orientation, then are unable to withdraw from the opening. Head entrapment by feet-first entry involves children who generally sit or lie down and slide their feet into an opening that is large enough to permit passage of their bodies but is not large enough to permit passage of their heads.

Section 2 - Playgrounds

Generally, an opening presents an entrapment hazard if the distance between any interior opposing surfaces is greater than 3.5 inches and less than nine inches. When one dimension of an opening is within this range, all dimensions of the opening should be considered together to evaluate the possibility of entrapment. Further, it applies to all openings regardless of their height above the ground (see figure below). Even openings that are low enough for children's feet to touch the ground can present a risk of strangulation for an entrapped child, because younger children may not have the necessary cognitive ability or motor skills to extricate their heads, especially if scared or panicked. There are guides and measuring devices to evaluate head entrapment.

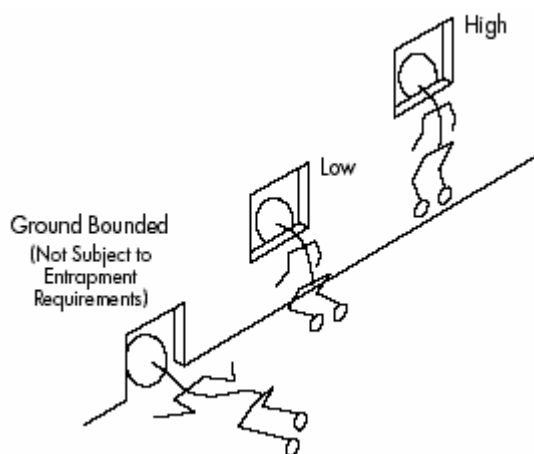

2.6 FALL PROTECTION

2.6.1 *Guardrails or protective barriers should be installed where appropriate*

Either guardrails or protective barriers may be used to prevent inadvertent or unintentional falls off elevated platforms. However, to provide greater protection, protective barriers should be designed to prevent intentional attempts by children seeking to defeat the barrier either by climbing over or through the barrier. For example, guardrails may have a horizontal top rail with infill consisting of vertical bars having openings that are greater than nine inches. Such openings would not present an entrapment hazard but would not prevent a child from climbing through the openings. A protective barrier should prevent passage of a child during deliberate attempts to defeat the barrier. Any openings between uprights or between the platform surface and lower edge of a protective barrier should prevent passage.

Platforms should be within $\pm 2^\circ$ of a horizontal plane and openings should be provided to allow for drainage. Either guardrails or protective barriers may be used to prevent inadvertent or unintentional falls off elevated platforms. However, to provide greater protection, protective head barriers should be designed to prevent intentional attempts by children seeking to defeat the barrier either by climbing over or through the barrier.

Preschool-age Children: Because younger children have poorer coordination and balance and are more vulnerable to injury than school-age children, guardrails or protective barriers are warranted at lower elevations. An elevated surface that is more than 20 inches above the protective surfacing should have a guardrail or protective barrier to prevent falls. Guardrails are

Section 2 - Playgrounds

acceptable for platforms over 20 inches but not over 30 inches high, but a full protective barrier may be preferable for this age group because it affords a greater degree of protection from falls. Protective barriers should always be used for platforms that are over 30 inches above the protective surfacing.

School-age Children: An elevated surface that is more than 30 inches above the protective surfacing should have a guardrail or protective barrier to prevent falls. For platforms over 30 inches but not over 48 inches high, guardrails are acceptable, although a full protective barrier always provides greater protection. Platforms that are over 48 inches above the protective surfacing should always have a protective barrier. An elevated surface is exempt from these recommendations if a guardrail or protective barrier would interfere with the intended use of the equipment; this includes most climbing equipment platforms that are layered so that the fall height does not exceed 20 inches on equipment intended for preschool-age children or 30 inches on equipment intended for school-age children.

The minimum-height should prevent the largest child from inadvertently falling over the guardrail. In addition, the guardrail should extend low enough to prevent the smallest child from inadvertently stepping under it (see Figure 13).

Preschool-age Children: the top surface of guardrails should be at least 29 inches high and the lower edge should be no more than 23 inches above the platform.

School-age Children: the top surface of guardrails should be at least 38 inches high and the lower edge should be no more than 28 inches above the platform. The minimum height should prevent the largest child from inadvertently falling over the protective barrier. In addition, because the protective barrier should not permit children to climb through or under it, openings in the barrier should preclude passage of the small torso.

Preschool-age Children: the top surface of protective barriers should be at least 29 inches high. Vertical infill for protective barriers may be preferable for younger children because the vertical components can be grasped at whatever height a child chooses as a handhold.

School-age Children: the top surface of protective barriers should be at least 38 inches high.

REFERENCES

PLAYGROUND SAFETY

1. *Handbook for Public Playground Safety*. U.S. Consumer Product Safety Commission, Washington D.C. Publication No. 325, <http://www.cpsc.gov> (4-7-05)
2. *Designing and Building Healthy Places*, Centers for Disease Control and Prevention, <http://www.cdc.gov/healthyplaces/> (8-14-07)
3. *Guide to Protecting Children's Health in School (Web site)*, U.S. Environmental Protection Agency. <http://www.epa.gov> (8-14-07)
4. *S.A.F.E. Play Areas*, National Program for Playground Safety, <http://www.playgroundsafety.org/safety/> (8-14-07)

Section 2 - Playgrounds

5. *Healthy School Environments*, National Clearinghouse for Educational Facilities (NCEF), <http://www.edfacilities.org/index.cfm> (8-14-07)
6. *Playground Safety*, The Center for Health and Health Care in Schools (CHHCS), <http://www.healthinschools.org/> (8-14-07)
7. *How Safe is Your Local Playground?*, Consumer Federation of America, <http://www.consumerfed.org/> (8-14-07)

Section 3 – Solid Waste Disposal Areas

INTRODUCTION

Outside trash and recycling Dumpster areas serve as an attractive haven for animals and insects, and also a nuisance for people. Food, food products and food wastes can attract such environmental pests as rodents, roaches and other insects and their larva. On school grounds, the trash and recycling areas should be located away from the school buildings, inaccessible to students and kept clean. The Dumpsters should be large enough to accommodate all trash and recyclables without overflowing. The entire area should be cleaned as often as necessary to prevent the accumulation of waste on the Dumpster pad and walls of the enclosure, if the area is enclosed. Students should not have access to the area at any time. Trash and recyclables can pose a potential health threat due to chemicals and foods in the discarded trash and recycling containers and due to pests that might be attracted to the waste.

3.1 TRASH, RECYCLING AND COMPACTOR CONTAINERS

3.1.1 Trash and recycling containers should be equipped with lids and the lids should cover the containers when not in use

Odors from trash attract unwanted animals such as raccoons, opossums, dogs, cats, rats, mice and insects. These pests can become destructive and many of them carry diseases. These unwanted guests will be attracted to school grounds if waste is accessible. There should be lids for all refuse and recycling containers and lids should be used to cover the container when it is not in the process of being filled. This will help to prevent odors and protect against unwanted insects and animals. Keeping lids on Dumpsters will help to contain trash in the Dumpsters and prevent litter from being blown around school grounds.

3.1.2 Trash, recycling and compactor containers should show no evidence of attracting pests

Trash and litter on the school grounds is more than aesthetically displeasing, it attracts unwanted insects and animals. All litter should be picked up and placed into waste receptacles that have lids.

REFERENCES

SOLID WASTE DISPOSAL AREAS

1. *Waste Management*, Air and Waste Management Association (AWMA), <http://www.awma.org/index.html> (8-14-07)
2. *Waste and Recycling*, U.S. Environmental Protection Agency, <http://www.epa.gov/highschool/waste.htm> (8-14-07)
3. *Wastes*, U.S. Environmental Protection Agency, <http://www.epa.gov/epawaste/index.htm> (10-27-10)

Section 4 – All Indoor Environments

INTRODUCTION

A clean, healthy and productive school environment for all students is the goal of the IES at the ODH. The 1995 GAO report on school facilities revealed that 83 percent of schools in Ohio have at least one unsatisfactory environmental feature. This report also indicated that 30 percent of schools have inadequate life-safety code features, 48 percent of schools have inadequate heating, ventilation and air conditioning features, 46 percent have inadequate electrical power and 39 percent have inadequate features in their plumbing systems.

In addition, 19 percent of the schools had unsatisfactory indoor air factors. Poor IAQ has been linked to headaches, sore throats, sleepiness, lethargy, dizziness and asthma. Incidents of acute asthma episodes among children have doubled in the past 10 years and asthma is currently the No. 1 reason American children are hospitalized. Five million children suffer from asthma and asthma-related deaths among children rose 78 percent between 1980 and 1993, according to the CDC. Good IAQ can increase productivity, morale and a sense of comfort for teachers, administrators and all school occupants.

The guidance provided in this section is intended to be used to improve the indoor school environment resulting in cleaner, healthier places for children to learn and develop.

4.1 GENERAL

4.1.1 *All school indoor environments should be clean, sanitary and free of hazards*

4.1.2 *There should be a five-step or fifteen foot walk off mat at all entry points into the building. If the area cannot accommodate a fifteen foot mat, the mat should be as long as the area will accommodate. Mats should be clean and replaced as necessary*

“On average 80 percent of the dirt on shoe soles is removed after the first five to six steps on a walk-off product.”³ In their Tools for Schools action kit, the U.S. EPA states, “Cleaner schools positively affect students and staff both physically and psychologically. Buildings with high dust levels have been associated with increased complaints, illnesses and discomfort. Specifically, dust mites have been found to trigger asthma attacks. In addition to dust, these techniques reduce other particles (such as pollens), that are known to cause allergic reactions.

Schools may want to place barrier floor mats at all entrances. These mats need to be long enough to allow five full steps for people entering the school. Most dirt will fall off on the mats rather than throughout the entire school, saving cleaning costs. Vacuum each barrier mat daily using a beater brush or beater bar vacuum. Always vacuum in two directions (in-line and side-to-side).”⁴

³ National Education Association, 2004

⁴ U.S. EPA, Tools for Schools kit, Background Information for Building and Grounds Maintenance Checklist

4.1.3 *Doors should be properly installed and maintained to fit tightly in their frame. Exterior doors should have no cracks, gaps or other visible openings that would allow the entry of insects or other pests into the building.*

Properly installed doors are important to the health and safety of occupants in schools. Doors should not admit insects or other pests when shut. Doors should also fit tightly in their frames to maintain proper air flow and ventilation. Doors should open to the outside for ease of egress.

4.2 MOISTURE, WATER DAMAGE AND MOLD

4.2.1 *Indoor environments should be sanitary with no sign of moisture, water damage or suspected mold on any interior surface*

Mold has been identified as an agent that can exacerbate certain health conditions, such as asthma and allergies. Mold spores are everywhere in our environment. However, for mold to develop beyond the spore stage, water is necessary. Any surface where mold is growing has had or is having a problem with moisture. The moisture problem should be corrected to prevent future mold growth. Once the moisture problem has been corrected the surface should be cleaned, if it is a cleanable surface, or removed and discarded when cleaning is not possible. Table 1 outlines proper cleaning methods depending on the surface on which mold is found. This table has been reproduced from the US EPA guidance document, "Mold Remediation in Schools and Commercial Buildings."

Ongoing water intrusion can cause structural damage as well as provide a food source for mold and insects. Some indicators of water intrusion or water damage are peeling paint, deteriorated siding, rotted window sills, mold on walls, peeling wallpaper and discolored ceiling tiles. Any sign of water intrusion should be evaluated and corrected promptly. Wet surfaces should be dried within 24-48 hours to inhibit mold growth. Table 2 outlines recommended clean-up methods, depending on surface area affected, as well as recommended PPE and type of containment necessary.

Table 1: Water Damage - Cleanup and Mold Prevention	
Guidelines for Response to Clean Water Damage within 24-48 Hours to Prevent Mold Growth*	
Water-damaged Material†	Actions
Books and papers	<ul style="list-style-type: none"> • For nonvaluable items, discard books and papers. • Photocopy valuable/important items, discard originals. • Freeze (in frost-free freezer or meat locker) or freeze-dry.
Carpet and backing - dry within 24-48 hours§	<ul style="list-style-type: none"> • Remove water with water-extraction vacuum. • Reduce ambient humidity levels with dehumidifier. • Accelerate drying process with fans.
Ceiling tiles	<ul style="list-style-type: none"> • Discard and replace.

Cellulose insulation	<ul style="list-style-type: none"> • Discard and replace.
Concrete or cinder-block surfaces	<ul style="list-style-type: none"> • Remove water with water-extraction vacuum. • Accelerate drying process with dehumidifiers, fans and/or heaters.
Fiberglas insulation	<ul style="list-style-type: none"> • Discard and replace.
Hard surface, porous floorings (Linoleum, ceramic tile, vinyl)	<ul style="list-style-type: none"> • Vacuum or damp wipe with water and mild detergent and allow to dry; scrub if necessary. • Check to make sure sub-flooring is dry; dry sub-florring if necessary.
Nonporous, hard surfaces (Plastics, metals)	<ul style="list-style-type: none"> • Vacuum or damp wipe with water and mild detergent and allow to dry; scrub if necessary.
Upholstered furniture	<ul style="list-style-type: none"> • Remove water with water-extraction vacuum. • Accelerate drying process with dehumidifiers, fans and/or heaters. • May be difficult to completely dry within 48 hours. If the piece is valuable, you may wish to consult a restoration/water damage professional who specializes in furniture.
Wallboard (Drywall and gypsum board)	<ul style="list-style-type: none"> • May be dried in place if there is no obvious swelling and the seams are intact. If not, remove, discard and replace. • Ventilate the wall cavity, if possible.
Window drapes	<ul style="list-style-type: none"> • Follow laundering or cleaning instructions recommended by the manufacturer.
Wood surfaces	<ul style="list-style-type: none"> • Remove moisture immediately and use dehumidifiers, gentle heat and fans for drying. (Use caution when applying heat to hardwood floors.) • Treated or finished wood surfaces may be cleaned with mild detergent and clean water and allowed to dry. • Wet paneling should be pried away from wall for drying.
<p>* If mold growth has occurred or materials have been wet for more than 48 hours, consult Table 2 guidelines. Even if materials are dried within 48 hours, mold growth may have occurred. Items may be tested by professionals if there is doubt. Note that mold growth will not always occur after 48 hours; this is only a guideline.</p> <p>These guidelines are for damage caused by clean water. If you know or suspect that the water source is contaminated with sewage, or chemical or biological pollutants, then PPE and containment are required by OSHA. An experienced professional should be consulted if you and/or your remediators do not have expertise remediating in contaminated water situations. Do not use fans before determining that the water is clean or sanitary.</p> <p>† If a particular item(s) has high monetary or sentimental value, you may wish to consult a</p>	

restoration/water damage specialist.

§ The subflooring under the carpet or other flooring material must also be cleaned and dried. See the appropriate section of this table for recommended actions depending on the composition of the subflooring.

Table 2: Guidelines for Remediating Building Materials with Mold Growth Caused by Clean Water*			
Material or Furnishing Affected	Cleanup Methods†	Personal Protective Equipment	Containment
SMALL - Total Surface Area Affected Less Than 10 Square Feet (ft²)			
Books and papers	3	Minimum N-95 respirator, gloves and goggles	None required
Carpet and backing	1, 3		
Concrete or cinder block	1, 3		
Hard surface, porous flooring (linoleum, ceramic tile, vinyl)	1, 2, 3		
Non-porous, hard surfaces (plastics, metals)	1, 2, 3		
Upholstered furniture & drapes	1, 3		
Wallboard (drywall and gypsum board)	3		
Wood surfaces	1, 2, 3		
MEDIUM - Total Surface Area Affected Between 10 and 100 (ft²)			
Books and papers	3	Limited or Full	Limited
Carpet and backing	1,3,4	Use professional judgment, consider potential for remediator exposure and size of contaminated area	Use professional judgment, consider potential for remediator/occupant exposure and size of contaminated area
Concrete or cinder block	1,3		
Hard surface, porous flooring (linoleum, ceramic tile, vinyl)	1,2,3		
Non-porous, hard surfaces (plastics, metals)	1,2,3		
Upholstered furniture & drapes	1,3,4		
Wallboard (drywall and gypsum board)	3,4		

Wood surfaces	1,2,3		
LARGE - Total Surface Area Affected Greater Than 100 (ft²) or Potential for Increased Occupant or Remediator Exposure During Remediation Estimated to be Significant			
Books and papers	3	Full Use professional judgment, consider potential for remediator/occupant exposure and size of contaminated area	Full Use professional judgment, consider potential for remediator exposure and size of contaminated area
Carpet and backing	1,3,4		
Concrete or cinder block	1,3		
Hard surface, porous flooring (linoleum, ceramic tile, vinyl)	1,2,3,4		
Non-porous, hard surfaces (plastics, metals)	1,2,3		
Upholstered furniture & drapes	1,2,4		
Wallboard (drywall and gypsum board)	3,4		
Wood surfaces	1,2,3,4		

Table 2 continued

*Use professional judgment to determine prudent levels of PPE and containment for each situation, particularly as the remediation site size increases and the potential for exposure and health effects rises.

Assess the need for increased PPE, if, during the remediation, more extensive contamination is encountered than was expected. Consult Table 1 if materials have been wet for less than 48 hours and mold growth is not apparent. These guidelines are for damage caused by clean water. If you know or suspect that the water source is contaminated with sewage, or chemical or biological pollutants, then the OSHA requires PPE and containment. An experienced professional should be consulted if you and/or your remediators do not have expertise in remediating contaminated water situations.

†Select method most appropriate to situation. Because molds gradually destroy the things they grow on, if mold growth is not addressed promptly, some items may be damaged such that cleaning will not restore their original appearance. If mold growth is heavy and items are valuable or important, you may wish to consult a restoration/water damage/remediation expert. Please note that these are guidelines only; other cleaning methods may be preferred by some professionals.

Cleanup Methods

- **Method 1:** Wet vacuum (in the case of porous materials, some mold spores/fragments will remain in the material but will not grow if the material is completely dried). Steam cleaning may be an alternative for carpets and some upholstered furniture.
- **Method 2:** Damp-wipe surfaces with plain water or with water and detergent solution (except wood —use wood floor cleaner); scrub as needed.
- **Method 3:** High-efficiency particulate air (HEPA) vacuum after the material has been thoroughly dried. Dispose of the contents of the HEPA vacuum in well-sealed plastic bags.
- **Method 4:** Discard- remove water-damaged materials and seal in plastic bags while inside of

containment, if present. Dispose of as normal waste. HEPA vacuum area after it is dried.

Personal Protective Equipment (PPE)

- Minimum: Gloves, N-95 respirator, goggles/eye protection
- Limited: Gloves, N-95 respirator or half-face respirator with HEPA filter, disposable overalls, goggles/eye protection
- Full: Gloves, disposable full body clothing, head gear, foot coverings, full-face respirator with HEPA filter

Containment

- Limited: Use polyethylene sheeting ceiling to floor around affected area with a slit entry and covering flap; maintain area under negative pressure with HEPA filtered fan unit. Block supply and return air vents within containment area.
- Full: Use two layers of fire-retardant polyethylene sheeting with one airlock chamber. Maintain area under negative pressure with HEPA filtered fan exhausted outside of building. Block supply and return air vents within containment area.

Table developed from literature and remediation documents including Bioaerosols: Assessment and Control (American Conference of Governmental Industrial Hygienists, 1999) and IICRC S500, Standard and Reference Guide for Professional Water Damage Restoration, (Institute of Inspection, Cleaning and Restoration Certification, 1999); see Resources List for more information.

4.3 DUST & CLUTTER

4.3.1 *There should be no excessive accumulation of dust or sediment on any surfaces.*

Dust is a known allergy and asthma trigger. High and low surfaces are not cleaned as often as those surfaces at eye level. Dust on higher surfaces can fall onto surfaces and students where it may be inhaled. Dust on lower surfaces can fall to the floor where it could be stirred up into the breathing zones of students as they move through the classroom.

4.3.2 *There should be no long-term storage of items that inhibit or restrict routine maintenance or cleaning.*

Items stored on the floor can inhibit cleaning. Storage containers placed in locations that block air flow, such as on or around unit ventilators, can reduce the quality of the indoor air and the thermal comfort of the occupants. Teaching supplies should be stored in containers that can be easily cleaned and moved. Educational staff should keep only materials that are necessary for instruction and will be used during the school year in the classroom. Clutter will contribute to pest infestations by providing shelter and food. Dust collection on clutter may contribute to asthma and allergy episodes in sensitive individuals.

A lack of storage space will contribute to clutter in the classroom. All storage containers should be kept on shelving or in cabinets so that floors and other horizontal surfaces can be cleaned. Storage containers should not be stored outside of cabinets, when cabinets are available. Keeping storage to a minimum allows for proper cleaning of the classroom and provides less of an attraction for pests. Nothing should be stored long-term that will inhibit proper and thorough cleaning of the floor or other horizontal surfaces.

4.4 PESTS

4.4.1 There should be no evidence of pests or obvious food sources for pests

Rodents and insects carry diseases and are triggers for asthma and allergy episodes in sensitive individuals. Cockroach allergens play a significant role in the development of asthma in early childhood. Certain proteins which act as allergens in the waste products and saliva of cockroaches can cause allergic reactions or trigger asthma symptoms in some individuals. Cockroaches and other pests, such as rats and mice, are often found in the school setting. Allergens from these pests may be significant asthma triggers for students and staff in schools. Pest problems in schools may be caused or worsened by a variety of conditions such as plumbing leaks, moisture problems, food crumbs not cleaned up, improper food handling and storage practices. In order to manage a pest problem, food, water and shelter sources for pests should be controlled in the school environment.

All food items, student lunches, snacks, foods used for crafts and animal foods should be stored in sealed containers. The containers should be free of all food residues.

4.5 CLASSROOM FURNITURE

4.5.1 Furniture and toys should be cleanable, clean and in good repair

Dust mites live on soft toys and upholstered furniture and feed upon dead human skin. Dust mites are a very common trigger for students with asthma or allergies. Because of the difficulty in maintaining upholstered furniture in a clean and mite-free condition, these items should not be allowed in the classroom environment. Toys provided for student use should be washable and laundered weekly or more often as necessary.

Student desks that are dirty, rough and in poor condition are not conducive to the learning environment. Dirty desks can be an attraction for pests and can harbor bacteria and viruses. Desk surfaces should be cleaned often to prevent a buildup of visible dirt. Desks that are cracked, missing portions of the surface, or are wobbly could cause injury to students from sharp or protruding edges. Students should not be given household cleaning chemicals to clean their desks.

4.6 WINDOW TREATMENTS & BANNERS

4.6.1 Drapes, blinds, shades and banners should be clean and in good repair

Dust and dirt that accumulates on drapes, blinds, shades and banners can be a source of triggers in the school environment for individuals with allergies or asthma resulting in allergy or asthma episodes. These items should be laundered as often as is necessary to avoid an accumulation of dust.

Other than stage curtains, the use of curtains and drapes in the school environment is discouraged for fire safety reasons. If these items are used in the school environment, they must be certified and tagged as flame resistant. See section 6.1.1 for OAC requirements for these items to be present in the school building. Stage curtains should be flame resistant according to the OAC, section 1301:7-7-03 (F) (4) which states, "Curtains and draperies: In occupancies in use groups A, E, I-2, I-3 and R-1, all curtains, draperies, hangings and other

decorative materials suspended from walls or ceilings should be noncombustible or maintained flame resistant in accordance with NFPA 701 listed in rule 1301:7-7-44 of the Administrative Code.” When curtains or drapes, including stage curtains, are cleaned, the flame-retardant chemical should be reapplied to the curtains, and the curtains should be tagged as flame resistant before they are put back into the school building.

4.7 WHITEBOARDS & CHALKBOARDS

4.7.1 *There should be no excessive accumulation of chalk or marker dust and markers should be low or no volatile organic compound emitting*

Excessive chalk or marker dust on chalkboard or whiteboard trays can be dispersed into the breathing environments of the occupants of the classrooms. The dust generated by these products can be inhaled and may trigger an allergy or asthma episode in sensitive individuals. Cleaning the trays of the different boards on a daily basis, when the room is not occupied by students, may help prevent or reduce the number of allergy and/or asthma episodes for sensitive individuals.

4.8 PORTABLE TABLES, FURNITURE & SHELVING

4.8.1 *Portable banquet tables, cafeteria tables and other portable furniture items, when not in a position intended for use, should be stored in a manner that is inaccessible to students or should be secured to the wall or floor to prevent injuries from tipping. Heavy furniture items should be moved only by authorized personnel. Televisions and heavy equipment that may pose a hazard by tipping or falling should be securely anchored to a cart, wall or floor and should be moved only by authorized personnel.*

Cafeteria tables that fold up and are mobile should not be stored in an unsecured manner around children. There are documented cases where children have been killed or seriously harmed when these tables have fallen on top of them. A warning label should be affixed to these types of tables to indicate the danger of tip-over when these tables are in the upright position. Mobile tables should be stored secured to the wall in a manner that will prohibit possible tip over or in a storage room that is inaccessible to students. More information on these tables can be requested from the CPSC.

Carts are commonly employed in schools to hold televisions and computer monitors for better classroom viewing by students. Unfortunately, such assemblies are inherently unstable due to their high center of gravity. The use of anchoring bolts or straps will prevent the TV or other equipment from falling off of the cart in the event of tipping – potentially injuring nearby students. Note, however, that the addition of such anchors does nothing to lower the inherent instability in the assembly.

The addition of weight, in the form of sandbags or other dense material, to the base of the cart (near the wheels) is one way to effectively lower the center of gravity for such assemblies. However, this will add significantly to the overall weight of the assembly making the unit more difficult to move.

4.8.2 *Free standing or mobile shelving should not pose a tip-over hazard and should be moved only by authorized personnel.*

The height, depth and weight distribution of a given shelving unit will determine its center of gravity and inherent stability. Because unstable shelving units may fall on nearby students and staff, such units should be physically anchored to prevent tipping.

4.9 CHEMICAL SAFETY

4.9.1 *Chemicals and cleaning products used in the classrooms should be inaccessible to all students with the exception of chemicals used during classroom instruction.*

Many cleaning products come in attractive colors to young children. Some cleaning products resemble juice or Kool-Aid and may be accidentally ingested by young children. Other products may simply be misused or used in unintended ways by students who do not or cannot follow label instructions. In order to protect children from poisoning or injury, all chemicals and cleaning products should be stored in a locked cabinet or kept inaccessible, particularly in the elementary school setting. It is preferred that all chemicals and cleaning products be stored in the custodial closet.

4.9.2 *Material Safety Data Sheets for every hazardous chemical used in the school building or on school grounds for cleaning, maintenance or instruction should be available to staff in areas where chemicals are used and in the school office or other appropriate designated central area of the building.*

All chemical and cleaning product containers should be properly labeled as to their contents. Material safety data sheets should be available to inform the users of those chemicals of the hazards that they pose, prevent misuse and to provide important information for emergency responders in the event of an emergency.

Certain cleaning chemicals emit Volatile Organic Compounds (VOCs) when stored that are readily inhaled by building occupants. Using cleaning chemicals that are water-based or that release low amounts of VOCs during use and not storing the chemicals in the classrooms will minimize risk of exposure from inhalation.

4.10 WALLS

4.10.1 *Walls should have paint and plaster intact with no visible bowing or evidence of cracks or damage.*

Any bowing or cracking of foundation should be inspected by an engineer or building inspector. Bowing or cracking could be an indication of a serious problem caused by a variety of factors.

Lead-based paint was not banned from use in the United States until 1978. Any school built before 1978 with chipping or peeling paint should be evaluated for lead by a licensed lead risk assessor or licensed lead paint inspector. Deteriorated lead-based paint can cause a child to become lead poisoned, if the paint is ingested or the dust is inhaled. All deteriorated surfaces in school buildings built before 1978 should be corrected by either a licensed lead abatement contractor, lead project designer or a lead safe renovator. A list of people who are licensed as

abatement contractors, designers, or renovators can be provided by the ODH, Division of Quality Assurance (DQA).

Window sills, window wells and floors where lead dust may have settled should be vacuumed with a HEPA vacuum. This vacuum will prevent the lead dust from being re-circulated into the air. Surfaces where leaded dust may have accumulated should be cleaned with soap and rinsed with clear water. Children become lead poisoned by touching surfaces with lead dust on them and putting their hands in their mouth. Children can also become lead poisoned by eating leaded paint chips or by breathing in leaded dust. While lead poisoning is of particular concern for children under the age of six due to the negative impact on cognitive development, lead poisoning can cause medical problems in persons of any age.

Water stains on walls can be an indication of water intrusion from the outside or an internal leak from the plumbing system. Water damage or stains can grow mold if the surfaces are not dried within 24 hours. Stains on walls that are caused from food or drink can attract pests. Both pests and mold can exacerbate allergies and trigger an asthma episode in sensitive individuals. Any stains on walls should be investigated as to the source and substance. If there is water damage on walls, the cause should be corrected. If mold is present determine the source of the water, correct the problem and have mold removed by cleaning thoroughly. Refer to table in 6.1.1.

4.11 FLOORS

4.11.1 Floors should be sanitary and dry with no tripping hazards.

Floor coverings should be smooth to prevent tripping hazards and should be long-lasting and constructed of materials able to withstand the wear and tear of a school environment. Floor coverings should also be easily cleanable. All floor coverings should be able to be completely dry within 24 hours of cleaning to inhibit mold growth.

4.11.2 Carpeting and vinyl cushion tufted textile should be sanitary, dry, and secure to the floor and not installed in vestibules and corridors within 15 feet of all building entrances or in areas prone to moisture accumulation or proximate to moisture sources, including, but not limited to, locker rooms, restrooms and spaces adjacent to sinks.

“Carpet can act as a trap for dirt, dust and other particles that fall to the ground.”⁵ Carpets that are not maintained properly through daily vacuuming and regular hot water extraction at least twice per year can become a contaminant source. Dirt, dust and mold can all cause asthma and allergy episodes in sensitive individuals. Odors coming from a carpet should be evaluated as to the source of the odor and the carpet cleaned or removed if necessary. When carpets become moist, a carpet water extractor should be used to remove as much moisture as possible. In addition, the HVAC system should be operated in a manner that facilitates dehumidification. During times of the year when opening windows is not feasible, mechanical ventilation to the area the wet carpet is located should be increased. This will help to expedite the drying process. Wet carpets that are not dried within 24-48 hours can promote mold growth.

Building entrances, hallways, restrooms or rooms with plumbing are where most of the dirt and water enter the building, making cleaning and maintenance of the carpet difficult. These areas receive the most use and will cause the carpet to wear more quickly than other areas.

Carpeting that is not secured or maintained in good condition can be a danger to all occupants in the school environment. Carpeting that has loose edges or is unraveling can serve as a tripping hazard, resulting in injuries. In addition, tears and holes do not allow for proper maintenance of the carpet.

All carpet maintenance should be performed according to guidance published by the Institute of Inspection, Cleaning and Restoration Certification.

4.11.3 *Area rugs should be sanitary and in good repair.*

Area rugs are difficult to maintain in a clean condition and can also be a tripping hazard to all occupants. Area rugs should be flat on the floor and free of tears or fraying of materials. If the area rug is too large to fit into a washing machine, the rug should be laundered professionally. It is recommended that individual mats that are easily cleanable be used to provide a softer surface for children to sit on when not at their desks.

4.12 **CEILINGS**

4.12.1 *Ceilings should be present, intact and sanitary with no water damage, stains, suspected mold or chipping or peeling paint.*

Water stains on a ceiling indicate a leak of some sort (roof, restrooms, other classroom plumbing, etc.). Rust stains may be an indication that condensation is accumulating on pipes above the ceiling. The water source should be identified and corrected in addition to repairing the ceiling. Ceiling tiles that have become wet and/or have mold on them should be thrown away and replaced with new ceiling tiles. Refer to the table in 6.1.1.

Ceilings with chipping or peeling paint should be repaired promptly. Some of the reasons that paint deteriorates are a lack of maintenance, water damage and high humidity levels. Water damage and high humidity levels should be corrected before the ceiling is repaired and repainted. Lead was used in paint until it was banned in 1978. When lead-based paint deteriorates, it becomes hazardous to people, especially children under 6 years of age. Deteriorated painted surfaces in school buildings built before 1978 should be considered lead hazards and should be stabilized in a lead-safe manner. For a complete listing of licensed lead professionals contact the ODH, DQA, Lead Poisoning Prevention Program.

4.13 **WINDOWS**

4.13.1 *Window panes and frames should be clean, intact and properly caulked or sealed and glazed.*

Window panes that are cracked pose a safety hazard to the students and staff in the school environment. The integrity of the window pane is compromised and could break or shatter causing injury to building occupants. Cracked window panes also allow for the air and weather to pass through causing problems with thermal comfort of the occupants.

Sealed windows prevent drafts, pest infestation and water intrusion. Windows should be re-glazed or re-caulked as necessary.

4.14 HVAC SYSTEMS

BACKGROUND

The heating, ventilation and air-conditioning (HVAC) system consists of all heating, cooling and ventilating equipment serving a school. This includes boilers, furnaces, chillers, cooling towers, AHUs, exhaust fans, ductwork and filters.

Not all HVAC systems are designed or configured to perform all possible HVAC system functions. For example, some buildings should rely on natural ventilation, achieved through open windows and doors. Others lack mechanical cooling equipment and few offer humidification capability. It is also important to note that system design is only one element affecting overall HVAC system effectiveness. The installation, operation and maintenance of HVAC systems rank equally with system design in determining how well these systems fulfill their original design intent.

Most AHUs distribute a mixture of outdoor air and re-circulated indoor air to the conditioned spaces. Some HVAC designs may include units that introduce 100 percent outdoor air while others simply recirculate the indoor air within the building. Uncontrolled quantities of outdoor air enter buildings by leakage through windows, doors and gaps in the building exterior. Thermal comfort and ventilation needs are met by supplying "conditioned" air, which is a mixture of outdoor and recirculated air that has been filtered, heated or cooled and sometimes humidified or dehumidified.

HVAC SYSTEM FUNCTIONS

A properly designed and functioning HVAC system performs the following functions:

- TEMPERATURE CONTROL to ensure thermal comfort
- RELATIVE HUMIDITY CONTROL also to provide thermal comfort and minimize mold
- FILTRATION to remove particulate material, odors and other contaminants
- VENTILATION to supply adequate outdoor air to occupied indoor spaces
- EXHAUST to remove airborne contaminants directly from the indoor environment
- DISTRIBUTION to deliver adequate amounts of conditioned air to meet ventilation and thermal comfort needs

COMMON CONFIGURATIONS

The two most common HVAC system configurations found in schools are **central air handling systems** and **unit ventilators**. Both systems can be outfitted to heat, cool, dehumidify, ventilate, filter and distribute the air within the spaces they control. However, central AHU's are designed to service multiple rooms, while unit ventilators are generally designed for individual rooms.

CENTRAL AIR HANDLING SYSTEMS

Central air handling systems supply and return air from multiple spaces back to a common, “central” AHU (Figure 1). Air from each individual room is drawn into the return air duct system and then mixed with air from all of the remaining rooms serviced by the AHU. This return air is then mixed with a fraction of outside air prior to entering the AHU, ensuring a continuous supply of outside air to the conditioned rooms while the fan is running. Once inside the AHU, the air is heated/cooled, humidified/dehumidified and filtered based on the design of the unit. Once conditioned, the air is then supplied back to the occupied spaces.

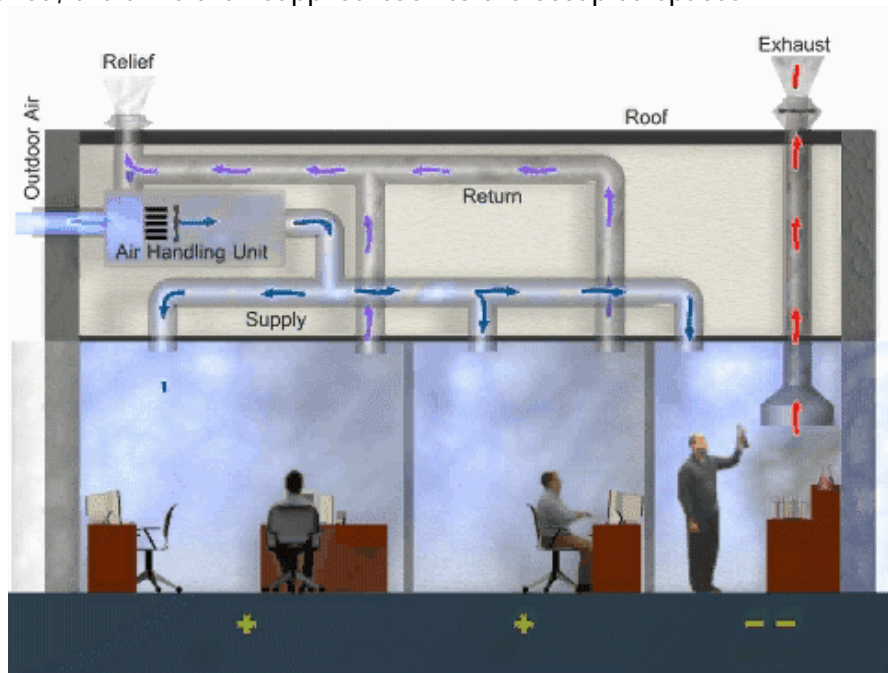

Figure 1 Central air handling system servicing three separate rooms

Central air handling systems installed in schools are configured according to one of the following two operational modes: Constant Volume (CV) or Variable Air Volume (VAV). The distinguishing characteristic of these systems is whether thermal conditions are satisfied by varying the temperature of the air or by varying the volume of air supplied to the controlled zone, as described below. CV systems are generally less energy efficient than VAV systems, but controls for outdoor air delivery are generally simpler to manage.

CONSTANT VOLUME SYSTEMS

In CV systems, variations in the thermal requirements of the controlled spaces are satisfied by varying the temperature of a CV of air continuously delivered to those spaces. The volume of air delivered can be set to satisfy applicable ventilation standards.

To ensure uniform thermal conditions in rooms served by a CV system, the rooms controlled by these systems should have similar thermal and ventilation requirements. This is because CV systems are equipped with a single thermostat, the placement of which is critical to the operational effectiveness of the system. The temperature of the air supplied to every room on the system is determined by the temperature at the thermostat. In essence, the room or hallway housing the thermostat always “wins” because the system will take its operating signals based on thermal conditions at that location only.

Consider the example depicted in Figure 2 where two offices are serviced by a single AHU. The office housing the thermostat also contains two large, south-facing windows, while the other office has no windows. During sunny summer days, extra cooling will be applied to BOTH offices based primarily on the solar heat gain in the office housing the thermostat. Unfortunately, with no windows in the other office and no corresponding solar heat gain, the excess cool air supplied to that space will produce temperatures well below the acceptable range for occupant thermal comfort.



Figure 2 Central air handling system serving two rooms illustrating dissimilar heating/cooling requirements due to solar heat gain through windows.

Similarly, consider the case of a sporadically occupied conference room and three regularly occupied offices, all controlled by the same CV system with the thermostat located in the conference room. Whenever the conference room is occupied, the AHU will supply extra cool air to that space based on the signal sent from the thermostat indicating additional cooling is required to overcome the heat gain caused by the additional occupants. Unfortunately, this extra cool air will also be supplied to each of the remaining three offices, much to the dismay of their occupants, who will likely be frozen out in the process. On cold winter days, the opposite effect will take place. With the conference room occupied, the air temperature will be maintained via body heat emanating from the occupants themselves, relieving the AHU of its usual job of providing warm air to the entire zone. Unfortunately, occupants of the remaining offices will again be frozen out, this time because their offices will not receive the necessary warm air to overcome the usual winter heat loss through the perimeter walls, windows, etc.

VARIABLE AIR VOLUME SYSTEMS

In VAV ventilation systems, variations in the thermal requirements of a space are satisfied by varying the volume of air that is delivered to the space at a constant temperature. VAV systems reduce HVAC energy cost by 10-20 percent over CV systems but complicate the delivery of

outdoor air. If the fraction of outdoor air is constant, the total volume of outdoor air will be reduced as the supply air volume is reduced. An inadequate outdoor air fraction, combined with an inadequate VAV box minimum setting, may result in inadequate outdoor air flow to occupied spaces. This would occur during part-load conditions. VAV systems also complicate pressure relationships in the building and make testing, adjusting and balancing more difficult.

UNIT VENTILATORS

Another common system for conditioning air in schools involves the use of self-contained AHUs known as unit ventilators or univents. These systems are commonly located in classrooms along an exterior wall, often beneath one or more windows (Figure 3). In newer systems, univents may be installed in the plenum space above the acoustical tile (or “dropped”) ceiling.

The primary benefit of using unit ventilators lies in the high degree of control they provide over centralized, CV systems. Because they control thermal conditions in only one primary space, they may be freely adjusted without affecting thermal conditions in other adjoining rooms. The disadvantages of these systems are that they are often not particularly effective at dehumidification, are more difficult to maintain and noisier than central AHUs.

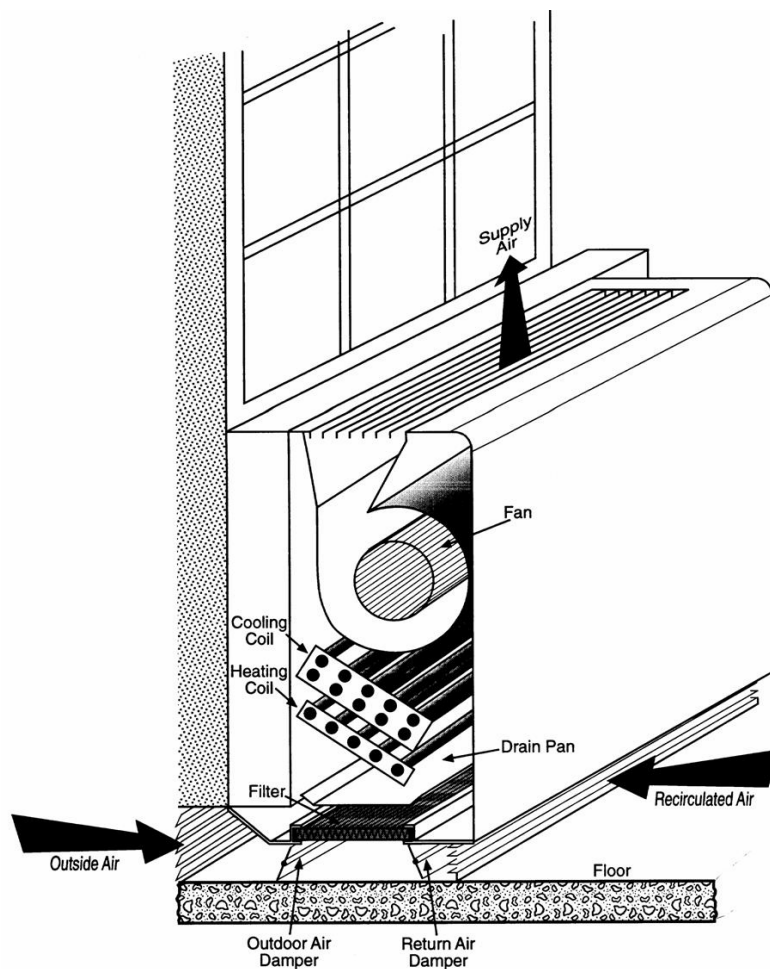

Figure 3 Wall-mounted unit ventilator

THERMOSTATS & CONTROLS

4.14.1 *HVAC systems should have the thermostatic controls set to operate the fan continuously during occupied periods*

Most HVAC systems in schools are equipped with thermostatic controls that have two switches. The first switch labeled "Setting" or "Mode" generally has three settings: "Heat" – "Off" – "Cool". This switch determines the mode of operation, i.e., heating, cooling or none.

The other switch labeled "Fan" has two settings "ON" – "AUTO." In the ON position, the fan itself will run continuously - irrespective of the mode of operation chosen - ensuring air is continuously circulated throughout the conditioned space. Assuming the outdoor air dampers are open and unobstructed, this setting simultaneously ensures that a fraction of outdoor air is drawn in and mixed with the air being recirculated, effectively ventilating the space. In the AUTO position, the fan will cycle on and off based on the heating/cooling demand within the space. However, during those periods when the fan is not actually running, no outside air is being supplied to the space and, consequently, no ventilation occurring. Therefore, to ensure proper ventilation, be certain the fan is on during all occupied periods.

ODORS, NOISE & VIBRATION

4.14.2 *HVAC systems should not have any excessive noise, vibration or odor from any system component.*

Excessive noise and vibration are disruptive to both students and staff. Noise and vibration detract from the teacher's ability to teach and the student's ability to learn and should be corrected whenever they occur. Excessive background noise is particularly disruptive to hearing-impaired individuals.

Odors emanating from the HVAC system within a given space may indicate one or more of the following conditions:

- 1) the HVAC system itself is acting as a contaminant reservoir;
- 2) contaminants are being drawn into the system from other areas within the building; or
- 3) contaminants originating outside the building are being drawn into the system (often through outside air intakes).

In all such scenarios, the source of the odor should be identified and corrected. One effective and systematic approach to identifying and correcting IAQ problems is outlined in the Coordinator's Guide to the U.S. EPA's IAQ Tools for Schools Kit.⁽¹⁾

MOLD & DEBRIS

4.14.3 *HVAC systems should not have any suspected mold or other debris on any system component*

Mold or debris on HVAC system components is problematic because of the likelihood of the airborne dispersal of those contaminants and possible inhalation by occupants. Excessive debris on HVAC system components is an indication of inadequate or deferred system maintenance and should be removed by thorough cleaning. The presence of visible mold is also an indicator of a possible moisture problem requiring further investigation.

A small amount of dust on duct surfaces is normal. Parts of the duct susceptible to contamination include areas with restricted airflow, duct lining or areas of moisture or condensation. Problems with biological pollutants can be prevented by:

- Minimizing dust and dirt buildup (especially during construction or renovation)
- Promptly repairing leaks and water damage
- Keeping system components dry that should be dry
- Cleaning components such as coils and drip pans
- Regular filter maintenance
- Proper housekeeping in occupied spaces.

AIR FILTRATION

4.14.4 HVAC systems should have air filtration media in central air handling units and unit ventilators

Proper air filtration is critical to controlling airborne particulate concentrations in the occupied space. Air filters are particularly effective for removing particulate material from the air stream.

Airborne particulate material is a complex mixture that may contain a variety of constituents ranging in size from hair strands to viruses. When considering the effectiveness of various air filtration media, we should be particularly concerned with its ability to remove respirable particulate material. These include particles 10 microns in diameter and smaller. Woven mesh filters are not effective at removing respirable particulate material from the air stream. As such, higher efficiency filters are often recommended as a cost-effective means of improving IAQ. Ensure all filtration media selected are consistent with the manufacturer's performance specifications for each AHU serviced.

Air filters having a minimum efficiency reporting value (MERV) of 7 (=25-30 percent dust spot efficiency) will provide a minimum acceptable level of filtration against respirable airborne particulate material without imposing an excessive power burden upon the lower capacity air handling units still in service in older schools across Ohio.

NOTE: Air filters should be visually inspected on at least TWO of each type of HVAC system present within a given school building. An authorized representative of the school maintenance staff should be present to actually open HVAC units and remove filters for inspection.

To ensure maximum effectiveness, all air filters should fit properly onto the filter support racks within the AHU with no gaps or openings between the rack and the filters or between the unit housing and the filters. In addition, filters should fit snugly against one another with spacers provided to hold them tightly in place.

The mere presence of visible particulate deposition or dirt on an air filter is not an effective indicator of filter change frequency. Filters are designed to capture and hold particulate material from the air stream. Depending on the nature and color of the contaminant stream, soiling may appear within only a few days following replacement. Conversely, a predominantly white contaminant stream on a white filter may not appear to be a problem, even though the filter in question is fully loaded.

Excessively loaded filters pose the risk of equipment failure by choking air flow sufficiently to freeze cooling coils during the cooling season.

All air filters should be replaced on a regular basis, based on pressure drop across the filter (where such instrumentation exists) or on a scheduled basis. Generally, a two- to three-month change interval is warranted for general classroom spaces.

Low-efficiency filters [American Society of Heating, Refrigerating and Air-Conditioning Engineers (ASHRAE) Dust Spot rating of 10 percent-20 percent], if loaded to excess, will become deformed and even blow out leading to clogged coils, dirty ducts, reduced IAQ, and greater energy use.

AIR SUPPLY DIFFUSERS & RETURN GRILLES

4.14.5 *HVAC systems should have unobstructed air supply grilles or outlets and air return grills or inlets with no rigged baffles, deflectors or barriers affixed.*

Obstructions on air supply diffusers and return grilles typically occurring in the form of debris or man-made barriers can severely restrict the flow of air through those components and compromise system performance, adversely impacting IAQ within those spaces. All such obstructions should be removed via cleaning or other means.

Man-made baffles or barriers affixed to air supply diffusers are often an expression of occupant dissatisfaction toward some aspect of HVAC system operation. Before such fixtures are removed, occupants should be interviewed by a representative of the maintenance staff to determine the exact concern giving rise to their installation.

Unit ventilators are often used as auxiliary shelving units by teachers and students in need of additional storage space for books, projects, or equipment. Unfortunately, such use invariably restricts air flow into and out of these units, compromising thermal conditions and IAQ within the controlled zone. Unit ventilator supply and return openings should always remain unobstructed.

4.15 INDOOR AIR QUALITY (IAQ)

BACKGROUND

In recent years, the U.S. EPA and the National Science Advisory Board have rated indoor air pollution as one of the top five environmental threats to human health. Studies from these agencies have shown that indoor pollutant levels can be two to 100 times higher than outdoor pollution levels. This is of particular concern because people spend up to 90 percent of their time indoors. Twenty percent of the U.S. population, nearly 55 million people, spend their days

in our elementary and secondary schools. A GAO report to congress in June 1994 said of the 3,600 school buildings in Ohio, 83 percent had at least one unsatisfactory environmental factor. About half of the buildings (48 percent) reported problems with heating, ventilation or air conditioning. HVAC problems, according to the National Institute of Occupational Safety and Health (NIOSH), are responsible for more than 50 percent of environmental health problems related to IAQ.

Failure to respond promptly and effectively to IAQ problems can have the following health, cost and educational process consequences:

- Increasing long- and short-term health problems such as cough, eye irritation, headache, asthma episodes and allergic reactions, and in rarer cases, life threatening conditions such as severe asthma episodes, Legionnaire's disease or CO poisoning.
- Promoting the spread of airborne infectious diseases.
- Aggravating asthma and other respiratory illnesses. Nearly one school-aged child in 13 has asthma, the leading cause of school absenteeism due to chronic disease. There is substantial evidence that indoor environmental exposure to allergens such as dust mites, other pests and molds play a role in triggering asthma symptoms. These allergens are found in the school indoor environment.
- Producing an unfavorable learning environment for children.
- Reducing productivity of teachers and staff due to discomfort, sickness, or absenteeism.
- Accelerating the deterioration and thus reducing the efficiency of the school's physical plant and equipment.
- Increasing the risk that school rooms or buildings will have to be closed and occupants temporarily relocated.
- Straining relationships among the school administration and parents and staff.
- Generating negative publicity that could damage a school's or administration's image and effectiveness.
- Creating potential liability problems.

Indoor air problems can be subtle and do not always produce easily recognized impacts on health, well-being or the physical plant. In some cases, only one or a few individuals may be strongly affected by what appears on the surface to be psychosomatic in nature because the majority of the school population does not appear to have any symptoms.

Children may be especially susceptible to air pollution. The same concentration of pollutants can result in higher body burden in children than adults because children breathe a greater volume of air relative to their body weight. For this and the reasons noted above, air quality in schools is of particular concern. Proper maintenance of indoor air is more than a quality issue; it encompasses safety and stewardship of our investment in the students, staff and facilities.

Good IAQ management can prevent many problems and includes the control of sources of airborne pollutants, the introduction and distribution of adequate outdoor air and the maintenance of acceptable temperature and relative humidity. Temperature and humidity cannot be overlooked because thermal comfort concerns underlie many complaints about poor air quality. Furthermore, temperature and humidity are among the many factors that affect indoor contaminant levels.

For further information on IAQ in schools, please see the U.S. EPA's *Tools for Schools* Action Kit at <http://www.epa.gov/iaq>. The goal of this kit is to provide clear and easily applied guidance that will help prevent IAQ problems and resolve such problems promptly if they do arise. It recommends practical actions that can be carried out by the school staff without the need for training and is flexible enough to conform to the specific needs of your school. It is free to any school. The ODH supports the use of *Tools for Schools* as part of a comprehensive indoor environmental management program.

ODORS

Indoor air pollutants, which are the cause of many odors, can originate within the building or be drawn in from outdoors. If pollutant sources are not controlled, IAQ problems can arise, even if the HVAC system is properly designed, operated, and maintained. Air contaminants consist of particles, dust, fibers, bio-aerosols, and gases or vapors. It may be helpful to think of air pollutant sources as fitting into one of the categories in the table below, *Typical Sources of Indoor Air Pollutants*. The examples given for each category are not intended to be a complete list.

In addition to the number of potential pollutants, another complicating factor is that indoor air pollutant concentration levels can vary by time and location within the school building, or even a single classroom. Pollutants can be emitted from point sources such as from science storerooms, or from area sources such as newly painted surfaces. Also, pollutants can vary with time, such as only when floor stripping is done, or continuously such as mold growing in the HVAC system.

Indoor air often contains a variety of contaminants at concentrations that are well below any standards or guidelines for occupational exposure. Given our present knowledge, it is often difficult to relate complaints of specific health effects to exposures to specific pollutant concentrations, especially because the significant exposures may be to low levels of pollutant mixtures.

Removal of the source is always the first choice for mitigation. If removal is not feasible, the pollutant source may be controlled through substitution of a less objectionable substance (i.e., red spirit thermometers vs. mercury thermometers). If the source is activity or use of a product, perhaps it could be timed to occur during unoccupied periods (i.e., cleaning chemicals used in evenings only so that VOCs can off gas before occupants return). Local exhaust at the point of the pollutant is another option (i.e., exhaust fan operational in all restrooms). Building ventilation and exhaust can be helpful in diluting and helping to exhaust indoor contaminants, but should not be the primary method of remediation. However, if building ventilation is not working appropriately, lack of ventilation will most certainly make any indoor environmental problem worse.

Typical Sources of Indoor Air Pollutants			
Outside Sources	Building Equipment	Component/Furnishings	Other Indoor Sources
Polluted	HVAC	Components	Science

<p>Outdoor Air</p> <p>Pollen, dust, fungal spores; industrial emissions; and vehicle emissions</p> <p>Nearby Sources</p> <p>Loading docks; odors from Dumpsters; and Unsanitary debris or building exhausts near outdoor air intakes</p> <p>Underground Sources</p> <p>Radon; pesticides; and leakage from underground storage tanks</p>	<p>Equipment</p> <p>Microbiological growth in drip pans, ductwork, coils and humidifiers; improper venting of combustion products; and dust or debris in ductwork</p> <p>Non-HVAC Equipment</p> <p>Emissions from office equipment (volatile organic compounds and ozone); emissions from shops, labs, cleaning processes; Air fresheners; Ozone-generating air purifiers</p>	<p>Microbiological growth on soiled or water-damaged materials; dry traps that allow the passage of sewer gas; materials containing volatile organic compounds, inorganic compounds, or damaged asbestos; and materials that produce particles (dust)</p> <p>Furnishings</p> <p>Emissions from new furnishings and floorings; and microbiological growth on or in soiled or water-damaged furnishings</p>	<p>laboratories; vocational arts areas; copy/print areas; food prep areas; cleaning materials; emissions from trash; pesticides; odors and volatile organic compounds from paint, chalk, adhesives; occupants with communicable diseases; dry-erase markers and similar pens; insects and other pests; and personal care products. Air fresheners.</p>
---	---	--	--

VENTILATION

4.15.1 *HVAC systems should provide adequate ventilation to prevent reasonable health complaints and to remove or dilute contaminants within the capacity of the system.*

Adequacy of ventilation can be difficult to evaluate. The Ohio Mechanical Code (OMC) recommends air flow standards, but these standards may be different based on the age of the building you are inspecting. The following ASHRAE guideline has been adopted into OMC and ODH recommends it be used as a standard for gauging adequacy of ventilation. Should ventilation not conform to these guidelines, further investigation may be necessary. Start with asking school facilities staff to provide documentation that the current system was installed correctly and is being operated and maintained according to manufacturer's/designer's specifications. If documentation cannot be provided and conditions cannot be resolved to meet

guidelines, it should be recommended the school contact a qualified HVAC professional to more thoroughly assess the situation and to develop remediation recommendations.

4.15.2 *Indoor CO₂ concentrations should not exceed 700 ppm above the outdoor ambient level.* [This recommendation is based on accepted Standards but not required by law]

Carbon dioxide (CO₂) is present in outdoor air. It is also a by-product of human breathing. Carbon dioxide by itself is not considered a health issue by any of the regulatory agencies until those levels reach as much as 5,000 ppm. The real issue focuses on the contaminants commonly found in indoor environments. Contaminants such as particles from construction activities or dust, gases (from personal care items or cleaning chemicals) and biologicals caused by molds or bacteria, can all be present in the occupied environment. As CO₂ levels produced by the occupants of a building space, rise in response to low outside air supplies, so might levels of other contaminants rise, leading to IAQ complaints. Bringing in outside air to dilute CO₂ levels will also help to dilute the other health-affecting contaminants in the space. CO₂ does not cause human health symptoms at levels commonly found in even poorly ventilated school buildings. However, poor ventilation may be frequently associated with headache and fatigue.

The amount of outdoor air considered adequate for proper ventilation has varied substantially over time. Because updating building codes often takes several years, the building code, if any, that was in force when your school HVAC system was designed, may well have required a lower amount of ventilation than what is currently considered adequate. In keeping with ANSI/ASHRAE Standard 62.1-2004: *Ventilation for Acceptable Indoor Air Quality*, ODH recommends that indoor CO₂ concentrations not exceed outdoor levels by more than 700 ppm.

THERMAL COMFORT

4.15.3 *School environmental health and safety inspections may include assessment of temperature and relative humidity which should be kept - within the capacity of the heating, ventilating and air conditioning system installed in the building - in accordance with table/chart below.* [This recommendation is based on accepted Standards but not required by law]

Temperature and humidity cannot be overlooked in the school environment because thermal comfort concerns underlie many complaints about poor air quality. Furthermore, temperature and humidity are among the many factors that affect indoor contaminant levels. A number of variables interact to determine whether people are comfortable with the temperature and relative humidity of the indoor air. The amount of clothing, activity level, age and physiology of people in schools vary widely, so the thermal comfort requirements vary for each individual. The ASHRAE Standard 55-1992 describes the temperature and humidity ranges that are comfortable for 90 percent of people engaged in largely sedentary activities. A summary of the standard is charted below. The ASHRAE standard assumes "normal" indoor clothing. Added layers of clothing reduce the rate of heat loss.

Uniformity of temperature is important to comfort. Comfort is important for students and staff to be able to concentrate on their jobs and perform at their best. Rooms that share a common heating and cooling system controlled by a single thermostat may be at different temperatures. Temperature stratification is a common problem caused by convection, the tendency of light, warm air to rise and heavier, cooler air to sink. If air is not properly mixed by the ventilation

system, the temperature near the ceiling can be several degrees warmer or cooler than near the floor, where young children spend much of their time. Even if air is properly mixed, uninsulated floors over unheated spaces can create discomfort in some climate zones. Large fluctuations of indoor temperature can also occur when thermostats have a wide "dead band" (a temperature range in which neither heating nor cooling takes place).

Radiant heat transfer may cause people located near very hot or very cold surfaces to be uncomfortable even though the thermostat setting and the measured air temperature are within the comfort range. Schools with large window areas sometimes have acute problems of discomfort due to radiant heat gains and losses, with the locations of complaints shifting during the day as the sun angle changes. Poorly insulated walls can also produce a flow of naturally convecting air, leading to complaints of draftiness. Closing curtains reduces heating from direct sunlight and reduces occupant exposure to hot or cold window surfaces.

Large schools may have interior ("core") spaces in which year-round cooling is required to compensate for heat generated by occupants, office equipment and lighting, while perimeter rooms may require heating or cooling depending on outdoor conditions.

Humidity is a factor in thermal comfort. Raising relative humidity reduces a person's ability to lose heat through perspiration and evaporation, so that the effect is similar to raising the temperature. Humidity extremes can also create other IAQ problems. Excessively high or low relative humidity can produce discomfort, high relative humidity can promote the growth of mold and mildew and low relative humidity can accelerate the release of spores into the air.

Recommended Ranges of Temperature and Relative Humidity		
Relative Humidity	Winter Temperature	Summer Temperature
37%	68.5°F-75.5°F	74.0°F-80.0°F
40%	68.0°F-75.0°F	73.5°F-80.0°F
50%	68.5°F-74.5°F	73.0°F-79.0°F
60%	67.5°F-74.0°F	73.0°F-78.5°F

Recommendations apply for persons clothed in typical summer and winter clothing, at light, mainly sedentary, activity.
Source: Adopted from ASHRAE Standard 55-1992, Thermal Environmental Conditions for Human Occupancy.

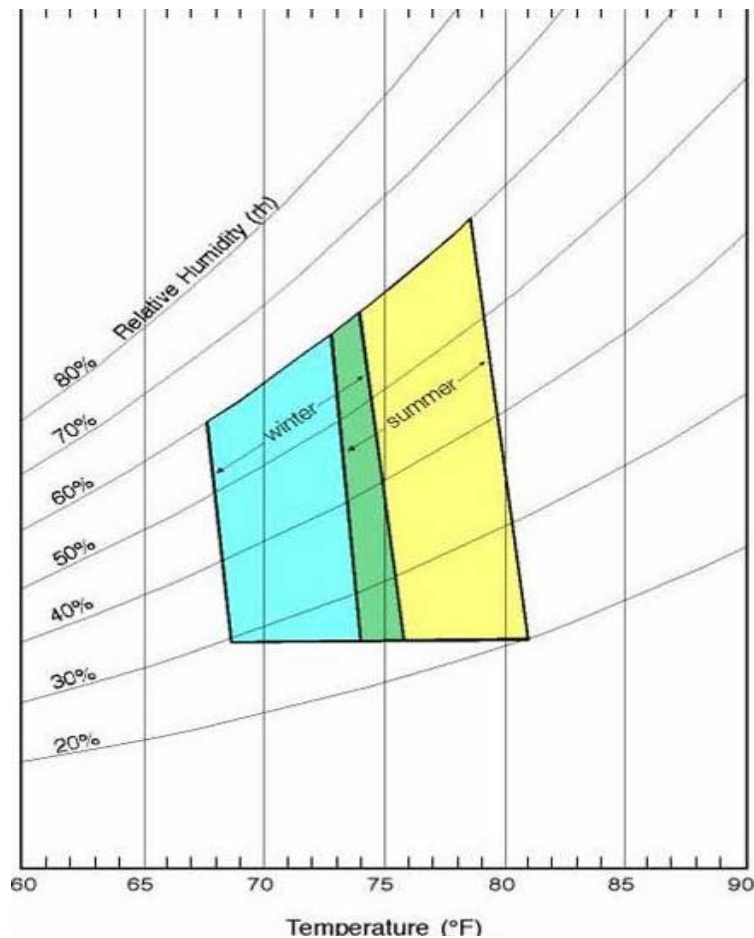

In those buildings lacking mechanical cooling equipment, occupants should rely entirely on natural ventilation and fans to provide sufficient air movement to effect cooling during hot periods. In such cases, the thermal comfort parameters specified above will invariably be exceeded with little recourse available.

4.16 ANIMAL MANAGEMENT

4.16.1 *There should be no excessive accumulation of animal waste in animal containers or cages.*

Animals that live in an unclean environment can become ill and the animal or the animal's environment may produce undesirable odors. Animal waste should be removed on a daily basis to protect the health of the students and staff and the health of the animal.

4.16.2 *Animal containers or cages should be equipped with properly fitting lids.*

To prevent animals from escaping from their cages/containers and roaming the school building freely, all cages/containers should be equipped with tight fitting lids.

4.16.3 *Hand washing facilities should be available and immediately used when animals are handled in the classroom.*

Certain animals can transmit bacteria to humans through handling. Proper hand washing facilities include warm running water, soap and disposable towels. The CDC has the following recommendations when handling reptiles and amphibians.

**Recommendations for preventing transmission of
Salmonella from reptiles and amphibians to humans**

- Pet-store owners, health-care providers and veterinarians should provide information to owners and potential purchasers of reptiles and amphibians about the risks for and prevention of salmonellosis from these pets.
- Persons at increased risk for infection or serious complications from salmonellosis (e.g. children aged less than 5 years and immunocompromised persons) should avoid contact with reptiles and amphibians and any items that have been in contact with reptiles and amphibians.
- Reptiles and amphibians should be kept out of households that include children aged less than 5 years or immunocompromised persons. A family expecting a child should remove any pet reptile or amphibian from the home before the infant arrives.
- Reptiles and amphibians should not be allowed in child-care centers.
- Persons should always wash their hands thoroughly with soap and water after handling reptiles and amphibians or their cages.
- Reptiles and amphibians should not be allowed to roam freely throughout a home or living area.
- Pet reptiles and amphibians should be kept out of kitchens and other food-preparation areas. Kitchen sinks should not be used to bathe reptiles and amphibians or to wash their dishes, cages or aquariums. If bathtubs are used for these purposes, they should be cleaned thoroughly and disinfected with bleach.
- Reptiles and amphibians in public settings (e.g. zoos and exhibits) should be kept from direct or indirect contact with patrons except in designated animal-contact areas equipped with adequate hand-washing facilities. Food and drink should not be allowed in animal-contact areas.

4.16.4 *Animals should not be permitted to roam in the school building, except for therapy animals or animals that are used for assistance.*

Animals can pass diseases to humans by way of bite, scratch and/or fecal contamination. Examples of diseases that can be transmitted by animals include rabies, ringworm, roundworm, tapeworm and histoplasmosis, among many others (for a complete list, visit http://www.cdc.gov/healthypets/browse_by_diseases.htm). Furthermore, individuals with suppressed immune systems may be more susceptible to contracting a disease from an animal.

Biologics associated with animals such as hair and fecal matter can also cause respiratory inflammations and asthma complications in children. Some children are allergic to pet dander (skin flakes of animals), as well as their saliva and urine and these substances can cause sneezing, wheezing and running eyes and nose in those affected.

4.16.5 *Animals should not be permitted on surfaces where food or drink is prepared or consumed.*

Food and drink should not come in contact with any pet materials or secretions, to avoid cross-contamination and human infection. The materials animals secrete, including urine, saliva and feces, can contaminate food and cause the transfer of disease from animal to human. Such diseases include *E. coli* and salmonellosis, among many others (for a complete list, visit http://www.cdc.gov/healthypets/browse_by_diseases.htm). It is therefore important that pets and pet secretions do not come in contact with areas used to prepare food or drink, to ensure the health and safety of those in the school environment.

4.16.6 *The following types of animals should not be permitted on school grounds.*

- (i) Nonhuman primates;*
- (ii) Rabies vector species, including raccoons, bats, skunks, coyotes or fox;*
- (iii) Wolves or wolf-dog hybrids;*
- (iv) Aggressive or unpredictable animals;*
- (v) Stray animals with unknown health and vaccination history;*
- (vi) Venomous or toxin-producing spiders, insects, reptiles and amphibians;*
- (vii) Dogs, cats, and ferrets under sixteen weeks of age; and*
- (viii) Dogs, cats, and ferrets that are not current on rabies vaccinations.*

4.16.7 *In addition to the animals listed above, the following animals are not permitted in classrooms with children under five years of age.*

- (i) Ferrets*
- (ii) Reptiles and amphibians; and*
- (iii) Chicks, ducklings, and hatching eggs*

4.16.8 *All animal feed should be in tightly sealed and labeled containers and separate from human food.*

4.17 PLUMBING FIXTURES

4.17.1 *All plumbing fixtures should be in good repair.*

Water leaks from plumbing can be costly because of increased water charge and because of increased potential for mold growth and pest infestation. All leaking plumbing fixtures should be repaired immediately and the area affected dried and cleaned. All plumbing should be maintained in good repair.

4.17.2 *Drinking fountain streams should crest a minimum of one inch above the mouth guard of the fountain but should not be so high as to promote water spillage onto the floor.*

The human mouth contains a multitude of microorganisms that can be transmitted to others via the mouth guard on the drinking fountains. The water stream should be from a free jet projected at an angle from the vertical. To prevent students from touching the mouth guard while taking a drink, the water should stream at least one inch above the mouth guard but not so high that the floor beneath the fountain becomes wet.

4.17.3 *All sinks should be maintained in accordance with Section 10.1 of this manual.*

4.18 DIAPERING FACILITIES

4.18.1 *Hand washing facilities should be available in rooms where restroom assistance is provided.*

There are students in the school environment who have special needs and require assistance when using the restroom. Specially designated areas where this assistance occurs should be equipped with hand washing facilities to prevent the spread of disease and to promote good hygiene. Hand washing facilities should be equipped with warm running water, soap and disposable hand towels.

4.18.2 *Diapering facilities should be sanitary and in good condition. Elevated diapering facilities should be properly guarded to prevent falls.*

There are a multitude of different bacteria that are shed in fecal material that can be transmitted to people and cause illness. All diapering surfaces should be disinfected after each use to prevent and control the spread of disease.

Any time personal hygiene assistance for an occupant in the school environment occurs on an elevated surface, proper guarding to prevent falls should be in place.

4.19 LIGHTING

4.19.1 *Lighting should be provided within 10% of the proper level of foot-candles, as found in Appendix B of this manual, in all areas of the school building; guarding or shields should be present on fixtures designed to be equipped with guards or shields or provided in areas where potential impact hazards exist.*

Adequate lighting levels are essential for a quality educational environment. Every school should have enough light for students to learn and see all areas of the classroom, for teachers to use different media for instruction and for custodial staff to properly clean. The lighting used in a school building should be a combination of natural (indirect) and artificial (direct).

“T” type light bulbs have a self-extinguishing feature that shuts off the light within 15 minutes after the outer bulb is broken. “T” type light bulbs may be used in either open fixtures or enclosed fixtures. FDA requires packaging for “T” type light bulbs to include the following statement:

“This lamp should self-extinguish within 15 minutes after the outer envelope is broken or punctured. If such damage occurs, TURN OFF AND REMOVE LAMP to avoid possible injury from hazardous shortwave ultraviolet radiation.”

“R” type light bulbs are not self-extinguishing. “R” type light bulbs should be installed only in light fixtures that are fully enclosed by a lens or glass or plastic to shield people from the UV radiation, or in areas where people will not be exposed to UV radiation if the outer bulb breaks. FDA requires packaging for “R” type light bulbs to include the following statement:

“WARNING: This lamp can cause serious skin burns and eye inflammation from shortwave ultraviolet radiation if outer envelope of the lamp is broken or punctured. Do not use where people will remain more than a few minutes unless adequate shielding or other safety precautions are used. Lamps that will automatically extinguish when the outer envelope is broken are commercially available.”

Lighting fixtures may need some type of guarding over the bulb to prevent cuts from broken bulbs and ultra-violet (UV) radiation from mercury vapor light bulbs. Mercury vapor lights are commonly used in gymnasiums. The U.S. Food and Drug Administration issued a warning regarding ultraviolet radiation burns from high intensity metal halide and mercury vapor lights in December 2005. Injury from exposure generally occurs to the eyes and skin of exposed individuals. As a result of those injuries, the FDA recommends that schools use “T” type mercury vapor light bulbs or fully enclose the fixtures that contain the “R” type light bulbs that have been found to cause the injuries.

4.20 NOISE

4.20.1 *There should be no excessive noise in the school building so as to create hearing hazards or disrupt classroom instruction.*

Recent studies have shown that student performance on standardized tests is inversely correlated with noise levels. As noise increases, performance decreases. We also know that 13 in 100 students demonstrate some level of hearing loss that impacts their ability to hear instruction in the presence of background noise. The most frequent culprits for noise in the

school environment are outside noise (traffic or industry) and noise from within the school (instrumental music rooms, industrial arts rooms, or gymnasium).

The Occupational Safety and Health Administration (OSHA) requires worksites that register above 85 decibels institute a hearing loss reduction program. A standard threshold for residential noise and what is usually recommended in the school environment is 70 decibels. However, noise levels above 58 decibels can interfere with voice communications and for some people can affect thought processes.

A number of techniques are used to reduce noise levels in schools and emanating from schools, including:

- Building finishes and construction details designed to minimize noise impacts in sensitive areas such as instrumental music rooms, technology workshops and gymnasiums.
- Timing and arrangement of concurrent classes next to noise producing rooms to minimize noise.
- A noise program within the school to train building occupants about the hazards of noise and how to reduce it.
- A range of solutions to deal with road traffic noise, including acoustically sealing walls closest to the noise source, mechanically ventilating rooms and construction of barriers between the noise source and the affected site.
- Measures to deal with air traffic noise, including orientation of rooms to reduce noise exposure; use of noise-attenuating materials and construction techniques; larger than normal roof overhangs and heavily insulated roofs with acoustically absorbent eaves linings; and soft finishes to the ground immediately adjacent to windows to reduce sound reflection into openings.
- Careful siting of rooms housing noise-producing activities (e.g. instrumental music rooms and workshops) to minimize impacts on other classrooms within the building and on neighbors beyond the school boundaries. This may also include careful location of windows.

4.21 GENERAL SAFETY

FAN SAFETY

4.21.1 *Box and stand fans should be properly guarded, clean and equipped with electrical cords that are maintained in good repair. Ceiling fans should be clean and in good repair.*

Poorly maintained portable box fans can become hazardous when electrical cords shed and wires become exposed. These exposed wires can prove to be an electrical hazard and can cause electrical fires and shortages. It is also important that fans plugged in to any outlet are placed out of walkways, to prevent tripping and falling over electrical cords. Ensuring that all fan blades are also properly guarded helps prevent injury by exposed fan blades.

Proper installation of ceiling fans is crucial to prevent injury by way of a fan falling from its supports. Local professionals should be contacted to undertake this task. These fans, once properly installed, should be maintained and cleaned regularly to prevent malfunction.

4.22 ELECTRICAL SAFETY

4.22.1 *All electrical cords, including extension cords, should be in good condition with no damage or fraying.*

Power cords for machinery and hand tools should be in good condition. Machinery or tools with damaged or frayed cords should be removed from use until they are repaired or replaced. In addition, electrical cords should not traverse aisles or walkways in such a manner as to pose a tripping hazard.

4.22.2 *There should be no use of ungrounded extension cords or use of extension cords for permanent equipment.*

Industrial arts instructors should provide and allow use of only heavy duty, grounded extension cords for temporary use and portable insulated strips with overload protection for more permanent situations. If a cord is damaged it should immediately be removed from use and repaired or replaced. Extension cords should not be used in lieu of permanent wiring.

4.22.3 *Electrical switches and electrical outlets should be in good repair.*

Switches and outlets should be covered, functional and allow for grounded cords.

REFERENCES

INTERIOR ENVIRONMENTS

1. *Indoor Air Quality Tools for Schools Kit*, U.S. EPA Indoor Environments Division (6609J) Document No. EPA 402-K-95-001, 2nd Edition. <http://www.epa.gov/iaq>.
2. *Indoor Air Quality*, U.S. EPA Indoor Environments Division, <http://www.epa.gov/iaq/> (8/14/07)
3. *S100 Standard Reference Guide for Professional On-Location Cleaning of Installed Textile Floor Covering Materials*, Institute for Inspection, Cleaning and Restoration Certification (IICRC), (2002)
4. *Air Pollution and Respiratory Health*, Centers for Disease Control and Prevention, <http://www.cdc.gov/nceh/airpollution/default.htm> (8-14-07)
5. *Indoor Air Quality*, American Society of Heating, Refrigerating and Air Conditioning Engineers (ASHRAE), <http://www.ashrae.org/> (8-14-07)
6. *Prevention of Allergies and Asthma in Children*, American Academy of Allergy, Asthma and Immunology (AAAAI), <http://www.aaaai.org/> (8-14-07)
7. *Indoor Environmental Quality*, American Industrial Hygiene Association (AIHA), <http://www.aiha.org/> (8-14-07)

8. *Indoor Air*, Air and Waste Management Association (AWMA),
<http://www.awma.org/index.html> (8-14-07)
9. *Indoor Air Quality*, National Clearinghouse for Educational Facilities (NCEF),
<http://www.edfacilities.org/index.cfm> (8-14-07)
10. Healthy Pets, Centers for Disease Control and Prevention,
<http://www.cdc.gov/healthypets/> (8-14-07)

Section 5 – Hallways & Stairwells

5.1 STORAGE

5.1.1 *There should be no storage of furniture or other items in the hallway or stairwells that may impede egress from the building.*

Students should be able to move through the hallways during school hours in a manner that does not impede the flow of traffic. Furniture or other items placed in the hallway may impede the egress of the building by its occupants and/or cause a tripping hazard. In either case, it is a hazard to store items in the hallway. Locker space should be sufficient for student storage of personal belongings.

5.2 STAIR TREADS & RAILS

5.2.1 *Stair treads and handrails should be secure and in good repair.*

Stair treads should allow the user to step securely. Stair treads that are not properly maintained can lead to falling and/or tripping hazards. Improperly maintained stair treads also make thorough cleaning difficult. As a result, dirt and dust can accumulate. Hand rails are used as a safety measure in the event a person begins to fall, they can grab the hand rail and prevent the fall. Hand rails are also used to steady a person while climbing or descending staircases. When hand rails are not secured and in good condition, falls may result.

Section 6 – Specialty Classrooms

THE BODY OF RECOMMENDATIONS INCLUDED IN THIS SECTION HAS BEEN DEVELOPED BY ODH TO ASSIST PUBLIC HEALTH AND SCHOOL OFFICIALS IN THEIR EFFORTS TO ENSURE A SAFE AND HEALTHY LEARNING ENVIRONMENT IN ALL VISUAL ARTS, INDUSTRIAL ARTS AND CAREER TECHNICAL EDUCATION ENVIRONMENTS. THE ITEMS INCLUDED HEREIN ARE THOSE ITEMS THAT ODH BELIEVES TO BE: 1) IMPORTANT TO THE PROPER OPERATION AND MAINTENANCE OF THESE ENVIRONMENTS AND; 2) READILY INSPECTABLE BY PUBLIC HEALTH INSPECTORS AND SCHOOL OFFICIALS.

HOWEVER, THIS SECTION IS IN NO WAY INCLUSIVE OF THE TOTAL BODY OF HEALTH AND SAFETY REGULATIONS REQUIRED OF SCHOOLS BY SUCH STATUTORY AUTHORITIES SUCH AS OSHA; THE OAC; AND THE OHIO PERRP. SCHOOL DISTRICTS ARE REQUIRED BY LAW TO COMPLY WITH ALL RELEVANT HEALTH AND SAFETY CODES AND STANDARDS PROMULGATED BY THESE AGENCIES INCLUDING, BUT NOT LIMITED TO, THE CODE OF FEDERAL REGULATIONS 29CFR1910 AND CHAPTER 4123 OF THE OAC. HENCE, COMPLIANCE WITH THE INSPECTION ITEMS PRESCRIBED HEREIN DOES NOT CONSTITUTE COMPLIANCE WITH ALL RELEVANT SAFETY AND HEALTH STANDARDS, NOR DOES IT ENSURE OR IMPLY THAT THE ENVIRONMENTS BEING INSPECTED ARE OTHERWISE "SAFE."

THE INSPECTIONS PERFORMED BY PUBLIC HEALTH INSPECTORS USING THIS STANDARD WILL PROMOTE A HIGHER DEGREE OF ENVIRONMENTAL HEALTH AND SAFETY IN OHIO SCHOOLS. HOWEVER, THE SAFETY COMPONENT OF THESE INSPECTIONS INVOLVES ONLY A CURSORY VISUAL INSPECTION OF THE MOST OBVIOUS SAFETY HAZARDS COMMONLY FOUND IN THE VISUAL ARTS, INDUSTRIAL ARTS AND CAREER TECH SETTINGS. TO EFFECTIVELY ENSURE THE SAFETY OF THESE ENVIRONMENTS, A COMPREHENSIVE SAFETY INSPECTION SHOULD BE CONDUCTED BY A QUALIFIED ENGINEER OR SAFETY PROFESSIONAL. SUCH INSPECTIONS ARE TYPICALLY QUITE EXTENSIVE AND TIME-CONSUMING AND DEMAND THAT THE INSPECTOR POSSESS A THOROUGH KNOWLEDGE AND EXPERIENCE BASE IN INDUSTRIAL SAFETY HAZARD RECOGNITION AND CONTROL. WHILE SUCH INSPECTIONS ARE BEYOND THE SCOPE OF THIS INSPECTION PROTOCOL, THE HAZARDS POSED BY THE VISUAL ARTS, INDUSTRIAL ARTS AND CAREER TECH SETTINGS WARRANT THEIR DELIBERATE AND IN-DEPTH INSPECTION. SCHOOL DISTRICTS MAY CONTACT THE OHIO BUREAU OF WORKERS' COMPENSATION (1-800-OHIO-BWC) TO SCHEDULE A COMPREHENSIVE SAFETY INSPECTION OF THEIR FACILITIES BY A TRAINED SAFETY PROFESSIONAL.

Section 6 – Specialty Classrooms

Specialty classrooms are any rooms or instruction areas where special supplies, chemicals or equipment are used that might pose safety or health hazards – i.e., science or chemistry rooms or laboratories, art classrooms, industrial arts classrooms.

Injuries in the school environment are a serious public health problem. Injuries occurring within the school shop class are a part of this problem that has received little attention. Studies done in other states indicate as many as 10 percent of injuries at school occur in the shop area. Shop injuries were defined as injuries that occurred in industrial art classes (woodshop, etc.) vocational educational classes or automotive classes. According to a study done in Utah, the majority (88.4 percent) of shop injuries involved equipment use. Equipment was misused in 37.9 percent and malfunctioned in 3.5 percent of the incidents. The leading injuries reported for shop equipment were cuts (70.9 percent), burns (6.0 percent) and scrapes (4.6 percent). Table saws, band saws and other saws were involved in nearly one half of the equipment injuries. Equipment was misused in 44.7 percent and malfunctioned in 10.5 percent of the incidents resulting in an ER visit. The majority (64.4 percent) of students sustained an open wound injury. The leaders for non-equipment injuries were cuts (45.4 percent) and fractures (9.2 percent).

Elementary School: Elementary students should not use any materials that present a hazard by skin contact, ingestion or inhalation. This would include materials that could become hazardous by misuse. Types of materials not recommended include organic solvents, shellac, alcohol, rubber cement, aerosol sprays, oil paints, permanent magic markers, clay dusts and glazes, etching acids, nonwater-based silk screen and India inks, any dyes and materials containing phenol or phenolic preservatives.

6.1 GENERAL SAFETY & SECURITY

6.1.1 All doors to specialty classrooms should be locked when the classroom is not occupied.

Equipment and chemicals commonly found in the specialty classroom pose numerous safety hazards to students. Chemicals may also represent an attractive nuisance to students inclined toward their misuse. Student access to any classroom containing specialty equipment or chemicals should be restricted to class periods only; doors should be locked during nonclass periods when teachers are not present.

Such controls will significantly reduce the likelihood of chemical exposures or injury from intentional misuse or by accident.

This section does not supersede the OBC, section 1008.1.8 which requires all egress doors to be readily opened from the egress side without the use of a key or special knowledge or effort.

6.1.2 Staff should be present while the room is occupied.

The teacher is responsible for ensuring that students are properly supervised in the specialty classroom. Students should not be left unattended, except in an emergency where the potential harm is greater than the perceived risk to students. Even then, risk should be minimized or responsibility transferred to another authorized person if the situation allows.

6.1.3 If gas is used, the master gas shutoff valve should be clearly labeled, easily accessible in the classroom and immediately operable by staff.

Section 6 – Specialty Classrooms

The master gas shutoff valve controls the flow of natural gas to all classroom fixtures. Clearly labeled signs pointing out the valve location and ensuring easy access to this valve will significantly reduce the time it takes students or teachers to access the valve in the event of a fire or other emergency.

6.1.4 *Food and drinks should not be consumed by students or during classroom instruction or in storage rooms or other areas where chemicals are used or stored.*

The science classroom commonly contains chemicals that are poisonous if they are ingested. These chemicals may be deposited on virtually any surface in the lab including, but not limited to chemical containers, desks, lab benches, equipment and books. Through hand contact with these surfaces, chemicals on the hands are transferred directly onto the foods and drinks as they are consumed. Food or drinks brought into the lab will significantly increase the likelihood of accidental ingestion and therefore should never be permitted in the science classroom.

6.1.5 *Aisles should be unobstructed.*

Trips and falls in this classroom area can result in serious injury. Also, classroom conditions may require rapid evacuation of the room. Therefore, aisles should be maintained free of clutter or debris.

6.2 **MERCURY**

6.2.1 *There should be no elemental mercury or thermometers, barometers or other portable devices containing elemental mercury in the classroom or storage room.*

Mercury is a naturally occurring element found in the air, water and soil. It exists in several forms: elemental or “metallic mercury,” inorganic mercury compounds and organic mercury compounds. Elemental or metallic mercury is a shiny, silver-white metal and is liquid at room temperature. It is used in thermometers, fluorescent light bulbs and some electrical switches.

Short-term or long-term exposures to elemental mercury can lead to serious health problems. Human exposure to elemental mercury occurs primarily from breathing contaminated air. Young children, who often play on the floor where elemental mercury may have been spilled, are particularly at risk. Mercury vapors are readily absorbed into the bloodstream from the lungs, and may damage the central nervous system. This is a major concern for small children as the central nervous system is still developing during the first few years of life. Elemental mercury can also affect a developing fetus. Other health effects related to elemental mercury poisoning include tremors, changes in vision or hearing, insomnia, weakness, difficulty with memory, headache, irritability, shyness and nervousness. Once released into the environment, mercury is very difficult and expensive, to clean up.



When dropped, elemental mercury breaks into smaller droplets that can slip through small cracks or become strongly attached to certain materials. At room temperature, exposed elemental mercury can evaporate to become an invisible, odorless, and highly toxic vapor. People can be exposed to elemental mercury vapor when products that contain mercury break and release mercury to the air, particularly in poorly-ventilated spaces.

Mercury is a serious concern in schools due to its toxic properties and the difficulty involved in detecting it in the environment. To minimize the amount of mercury at school, you must first identify where it is. Mercury can be found in a number of common science classroom equipment including thermometers and barometers. It may also be found on the chemical storage shelf in its elemental liquid form. School districts may contact the Department of Environmental Health & Safety at the Bowling Green State University to arrange for the disposal of metallic mercury or mercury-containing devices from school property.⁽⁴⁾

THE HEALTH HAZARD POSED BY ELEMENTAL MERCURY, COMBINED WITH THE READY AVAILABILITY OF SAFER ALTERNATIVES, MAKE THE USE OR STORAGE OF MERCURY ON SCHOOL PROPERTY BOTH UNNECESSARY AND UNDESIRABLE.

6.3 DUST & CLUTTER

6.3.1 *There should be no excessive accumulation of dust or sediment on any surfaces.*

Refer to Section 4.3 – “Dust & Clutter” – Dust and clutter can pose increased risk in specialty classrooms where dust or debris may contain more hazardous contaminants than in general classrooms.

6.4 PERSONAL PROTECTIVE EQUIPMENT

6.4.1 *Personal protective equipment should be in good repair and available for use when appropriate according to the safety plan.*

ANSI coded Z87- or Z87.1-approved safety goggles should be provided for each student when there is danger of chemical or projectile hazard. Specially marked, non-vented goggles should be available for contact lens wearers.

Sanitizing and/or sterilizing equipment or materials, e.g., ultraviolet cabinets or alcohol swabs should be available and used between classes to clean safety cover goggles.

Section 6 – Specialty Classrooms

Nonabsorbent, chemical-resistant aprons should be provided for each student during laboratory activities where there is a danger of spillage or spattering of chemicals or hot liquids.

Personal protective equipment (PPE) should be used only when other means of control are exhausted, such as substitution of less toxic materials or less hazardous techniques, ventilation or appropriate housekeeping. If PPE is needed it should meet standards set by OSHA. Types of PPE and some general information are provided below.

Head Protection

There is always a danger of hair becoming entangled in moving parts. Students with long hair should have their hair tied back, secured or tucked underneath their clothing.

Eye and Face Protection

Students' eyes can be exposed to a variety of hazards (i.e., flying objects, splashes of corrosive liquids or molten metal, dust, laser lights or infrared light). Eye protection should be designed to meet the standards for each activity.

Hearing Protection

When source control is not effective at lowering noise levels, or when a person in the facility cannot avoid direct exposure to noisy equipment or tools, hearing protection should be used. Many types of personal hearing protection devices are available, ranging from ear plugs to cup-type hearing protectors.

Respiratory Protection

The human respiratory system presents the quickest and most direct avenue of entry of hazardous materials, because it is connected with the circulatory system and the need to oxygenate tissue cells. Air may be contaminated with dusts, fumes and sprays. The most important objective is to prevent atmospheric contamination. This should be accomplished by engineering control measures (e.g., enclosure or confinement of operation, general and local ventilation and substitution of less toxic air). When effective engineering controls are not feasible, appropriate masks or respirators should be used.

Hand Protection

Statistics indicate injuries to the arms, hands and fingers account for more than a quarter of all disabling mishaps. Many industrial incidents are the result of operating machinery, using tools or handling materials. Gloves supplement good work practices to prevent hand injuries during handling of tools and materials. There are many types of gloves that are suitable for scrapes, cuts, oils, chemical, radiation, heat and flame.

Body, Foot and Leg Protection

Students require protection from the hazards of molten metal, sparks, splashing liquids, heat, cutting and impact. Welders need aprons made of fire-resistant fabric or leather. Personal protective footwear can protect feet against injuries, such as those from falling objects, accidental contact with sheet metal and sparks from welding and cutting operations. Although

Section 6 – Specialty Classrooms

safety shoes may present the ideal protection for feet, this may be impractical in certain situations. Some alternatives that may better fit particular situations could be foot guards, which protect the toes and instep against falling objects or a combination foot and skin guard, which protects both against flying particles and sparks from cutting/welding.

6.5 FUME HOODS

6.5.1 *Fume hoods should be in use when hazardous airborne contaminants are generated as part of classroom activities. Fume hoods should be properly maintained in accordance with manufacturer's instructions and inspected annually. Documentation of all maintenance and inspections should be readily available upon inspection.*

Operational chemical fume hood, vented through the roof to at least eight feet above the roof line should be employed where chemical experiments are conducted involving the generation of hazardous gas-phase contaminants. The hood(s) should not be within 10 feet of an exit or adjacent to a main aisle.

Proper functioning of the system may be qualitatively evaluated using a standard air current test. Using this method, a visible plume of smoke is released parallel to the face opening of the exhaust device at multiple locations across the face. Visible and even movement of the smoke into the exhaust device across the entire face opening may be interpreted as confirmation of sufficient air flow into the device.

6.6 SINKS

6.6.1 *Hand washing facilities should be available in the classroom and should be supplied as outlined in Section 10.1 of this manual. Laboratory sinks may fulfill this requirement, if properly supplied.*

6.7 HAZARD COMMUNICATION

6.7.1 *All containers of chemicals used in the classroom should be properly labeled, with the exception of containers used during an immediate classroom period.*

The following information should appear on all chemical container labels:

1. Chemical name and/or trade name of the product.
2. Chemical manufacturer or supplier-including address and telephone number.
3. Date received or date placed in the container.
4. Strength/concentration of the chemical.
5. Precautions to be observed and warning properties to note during handling or mixing.
6. Appropriate hazard symbol NFPA rating (see below).
7. Disposal method.

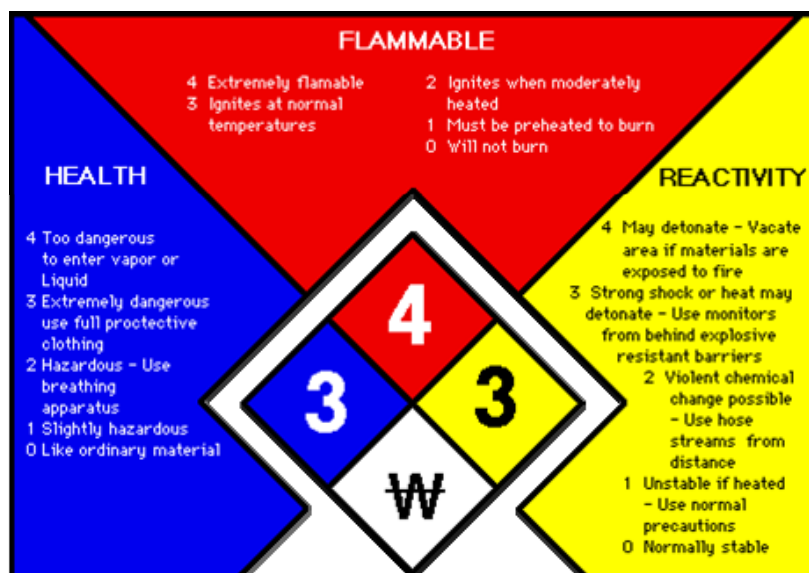

NOTE: Portable containers into which hazardous chemicals are transferred from labeled containers and which are intended only for use by the individual performing the transfer, within a single class period or work day, need NOT be labeled.

6.7.2 *Material safety data sheets (MSDS) should be accessible to staff for all classroom chemicals.*

An MSDS should be kept on file and readily accessible to building occupants for all hazardous chemicals used or stored in the lab. MSDS should be referenced for proper storage and for appropriate PPE. In addition, quick access to MSDS during an emergency will give first responders a clearer understanding of the hazards they may face and improve the quality and effectiveness of their response. Paper copies of MSDS should be kept in the chemical storage room and in the principal's office.

The following information should appear on all MSDS:

Chemical name and composition

Manufacturer and distributor name and address

Chemical and physical properties

Health/flammability/chemical reactivity hazard ratings

First-aid measures

Fire fighting measures

Accidental release/spill measures

Proper handling and storage procedures

Section 6 – Specialty Classrooms

Exposure limits

Toxicological information

PPE

Disposal considerations

6.8 CHEMICAL STORAGE

INTRODUCTION

The use of chemicals is an essential part of science education. Many of the chemicals commonly used in the laboratory are not especially hazardous, but clearly there are exceptions. In the laboratory, hazardous chemicals can be divided into the following four general categories:

- 1) corrosive 2) flammable 3) reactive 4) toxic

An effective way to prevent accidents involving chemicals is to isolate your chemical hazards. Chemical compatibility and security are essential components in this process. The two types of chemical hazards with which schools should be particularly concerned are corrosives (acids and bases) and flammable liquids. No other group of chemicals found on the entire school premises poses a greater threat to life and/or property. The improper storage of corrosives and flammable liquids constitutes an "event" waiting to happen.

The most effective way to isolate your flammable and corrosive hazards is to store them properly in approved chemical storage cabinets. Such cabinets isolate corrosives and flammable liquids from other incompatible chemicals, provide a higher level of security against theft and vandalism and will contain and control the hazards should an event occur.⁽⁵⁾

6.8.1 Chemical storage rooms and chemical storage cabinets should be inaccessible to students or locked while not in use.

The multiple hazards posed by laboratory chemicals warrant their strict control and limited student access. Such controls will significantly reduce the likelihood of accidental exposures or intentional misuse by students.

This section does not supersede the OBC, section 1008.1.8 which requires all egress doors to be readily opened from the egress side without the use of a key or special knowledge or effort.

6.8.2 A comprehensive chemical inventory list and disposal log should be present and immediately accessible to staff.

The chemical inventory list should include the chemical name, quantity and date received of every chemical on site. The chemical inventory should be maintained by either the science teacher or the head of the science department. The disposal log should contain the chemical name, date of disposal, method of disposal, responsible district employee, and receiver for each chemical disposed of.

6.8.3 Chemicals should be stored according to chemically compatible families and should be properly labeled.

Section 6 – Specialty Classrooms

Perhaps the single most important rule of chemical storage is to segregate incompatible chemicals which, if accidentally mixed, could cause fire, explosion or the generation of toxic gases. Hazardous chemical reactions can occur from improper storage when incompatible materials mix due to:

- Accidental breakage
- Container failure
- Fires, earthquakes and other natural disasters
- Mixing of gases or vapors from poorly closed containers
- Mistakenly storing incompatibles together because of improperly labeled containers

Store each of the following groups of chemicals separately from one another - either in separate locations or in appropriate tubs or secondary containers. Clearly and legibly label each container and storage location to indicate its compatibility group.

Recommended Chemical Storage Pattern: ⁽⁷⁾

INORGANIC	ORGANIC
Sulfur, Phosphorus, Arsenic, Phosphorus Pentoxide	Alcohols, Glycols, etc. (store flammables in dedicated cabinets)
Halides, Sulfates, Sulfites, Thiosulfates, Phosphates, etc.	Hydrocarbons, Esters, etc. (store flammables in dedicated cabinet)
Amides, Nitrates (not ammonium nitrate), Nitrites, etc.	Ethers, Ketones, etc. (store flammables in dedicated cabinet)
Metals, Hydrides (store away from water)	Epoxy compounds, Isocyanates
Hydroxides, Oxides, Silicates, etc.	Sulfides, Polysulfides, etc.
Arsenates, Cyanides (store above acids)	Phenols, Cresols
Sulfides, Selenides, Phosphides, Carbides, Nitrides	Peroxides, Azides, etc.
Manganates, Chromates, Permanganates, Borates	Acids, Anhydrides, Peracids, etc.
Chlorates, Chlorites, Perchlorates, Peroxides, Perchloric acid	Miscellaneous
Acids, except nitric. (store acids in dedicated cabinets)	Miscellaneous (Nitric Acid)

6.8.4 *Acids and bases should be stored in separate, dedicated cabinets.*

It is not uncommon to find acids and bases stored in the same cabinet, especially when the storage system employed is mistakenly based on alphabetical categorization. Acids and bases

react violently when brought together and should never be stored together. Instead, acids and bases should always be kept in separate, clearly labeled corrosives storage cabinets.

6.8.5 Nitric acid should be stored separately from all other acids.

Nitric acid, when mixed with acetic acid, can react and may sometimes produce a fire. It is therefore recommended that nitric acid be stored in a secondary container/compartiment within the acid storage cabinet. Some chemical cabinet manufacturers actually sell acid cabinets with just such a secondary containment device.

6.8.6 All flammable or combustible and corrosive liquids should be stored separately, in approved cabinets and properly labeled.

Flammable and combustible liquids should be stored only in certain types of approved containers. Approval for containers is based on specifications developed by organizations such as OSHA, NFPA or ANSI. Containers used by the manufacturers of flammable and combustible liquids generally meet these specifications.

Many types of containers are required depending on the quantities and classes of flammable or combustible liquids in use. A **safety can** is an approved container of not more than five gallons capacity that has a spring closing lid and spout cover. Safety cans are designed to safely relieve internal pressure when exposed to fire conditions. A **closed container** is one sealed by a lid or other device so that liquid and vapor cannot escape at ordinary temperatures.

A flammable liquid storage cabinet is an approved cabinet that has been designed and constructed to protect the contents from external fires. Storage cabinets are usually equipped with vents, which are plugged by the cabinet manufacturer. Although venting is generally not required by local codes, the absence of a vent may prevent the cabinet from protecting its contents. Storage cabinets should also be conspicuously labeled

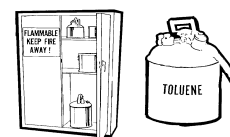

"FLAMMABLE – KEEP FIRE AWAY"

Requirements governing the storage of flammable and combustible liquids may be found in the Code of Federal Regulations Standard 29CFR 1910.106

6.8.7 Shelves or shelving units for chemical storage should be in good repair, adequately supported, have anti-roll lips and should be secured to the wall or floor.

The tipping of storage units containing chemicals may result in container breakage and the inadvertent mixing of incompatible chemicals. Such inadvertent mixing may result in fires, explosions or the generation of corrosive and toxic compounds in the indoor environment.

Storage shelving should be capable of supporting the weight of the shelf contents without bowing. The shelving should be attached to the cabinet or anchoring point securely (i.e., no missing clips). In addition, shelving units should be securely attached to the wall or floor to help prevent accidentally tipping the entire shelving unit. The tipping of a shelving unit or the

Section 6 – Specialty Classrooms

collapse of a shelf of chemicals could result in unintended combinations of volatile chemicals and could cause serious environmental and health problems.

Anti-roll lips will help to prevent chemical containers from sliding over the front edge of storage shelves during use.

6.8.8 *Chemical storage rooms may be vented with a mechanical exhaust system. If an exhaust system is present, it should operate continuously.*

All chemical storage rooms should be equipped with a functioning exhaust fan. This exhaust fan should remain on continuously. It should also be vented directly to the outside at least eight feet above the building roof line and located at least 50 feet away from any outside air intakes. In situations where these guidelines are not met, the school district should be encouraged to contact an industrial hygienist for further evaluation and recommendations.

6.8.9 *Chemicals should not be stored in fume hoods, on floors or above user's line of sight.*

Chemical fume hoods are not designed to prevent contact between incompatible chemicals. As such, the potential for fire, explosion or the generation of toxic compounds is adequate justification for prohibiting chemical storage within hoods. Chemicals stored on the floor, may be easily knocked over due to foot traffic. Leaks or spills will be uncontained and flow directly onto the floor posing an unnecessary slipping hazard in addition to the hazards defined above. Chemicals should be stored so the user can see the container to ensure safe container removal from the storage unit without inadvertently knocking other containers over in the process.

6.8.10 *Food and drinks should not be stored in refrigerators storing chemicals or specimens.*

Refer to 6.1.4 as the same potential cross contamination applies.

6.9 EMERGENCY EQUIPMENT

6.9.1 *Emergency showers and eyewash stations should be operational, unobstructed and located within ten seconds of all workstations. Eyewash stations should have at least fifteen minutes of continuous water flow with adequate pressure and should be capable of flushing both eyes simultaneously. Documentation that emergency showers and eyewash stations have been tested monthly should be available upon inspection.*

Hand pull, forearm or foot-operated face/body sprayers with adequate water pressure, should be strategically placed within approximately 10 seconds of any location in the room.

To test whether the safety shower is properly functioning, a bucket should be placed directly beneath the shower head then activated to ensure adequate flow. Note, that if showers have been tested and tagged indicating they have been tested monthly, the inspector need not test the shower.

Multiple faucet-type portable eyewash stations should be strategically placed within approximately 10 seconds of any location in the room. Eyewash stations should be forearm or foot-operated for hand-free operation.

Section 6 – Specialty Classrooms

Proper functioning should be tested by activating the unit to verify adequate flow. School staff should be encouraged to test these devices weekly to ensure proper functioning and to flush the devices with sufficient water to ensure that only clean water is available for eye washing during emergencies. Some portable eyewash stations come “preloaded” with the appropriate amount water in the cartridge or a storage reservoir so no plumbing is needed. In this case, the manufacturers recommended water replacement procedures should be followed as well. Eyewash stations should be able to provide at least 15 minutes of uninterrupted water flow. This precludes the use of squeeze bottle eyewash devices.

6.9.2 Squeeze bottle eyewash devices should not be used.

Such devices are ineffective and may actually be dangerous. Squeeze bottle devices only wash one eye at a time and are unable to provide the volume of water necessary to effectively wash the eyes of chemical contaminants. They are also prone to biological contamination should wash solutions become unsterile. Finally, they may also become contaminated from the introduction of other chemicals or body fluids due to horseplay or vandalism.

6.9.3 First aid and chemical spill kits should be appropriately supplied and immediately accessible to staff.

First aid kits should always be available and accessible to staff in the event of an emergency. Recommended supplies in the first aid kit are assorted bandages, cotton balls, splints, cold pack, tongue blades, face mask or shield, disposable gloves and isopropyl alcohol. This list is not all inclusive.

ACID/BASE SPILLS:

Containers of diatomaceous earth should be available in the classroom for general chemical spills. Spilled acids are best neutralized with powdered sodium hydrogen carbonate (sodium bicarbonate/baking soda) and bases with vinegar (5 percent acetic acid solution). Diatomaceous earth may be spread to absorb neutralized chemicals, swept and then disposed of properly.

6.10 HAZARDOUS MATERIALS

6.10.1 There should be no use or storage of dry or powdered pigments or dry or powdered clays.

6.10.2 There should be no use or storage of highly toxic pigments or paints.

6.10.3 There should be no use or storage of materials containing heavy metals. The following table lists the most toxic paint colors. MSDS should be obtained on all pigments because the name that appears on the tube of color may or may not truly represent the pigments present. The MSDS will identify the toxicity of the material. Manufacturers may keep the name of a color while reformulating the ingredients. If paint is described as “hue” (not pigment) on the label, there will be little to no toxic metal contained in the paint.

- ◆ If dry pigments must be used, they should be mixed within a glove box or inside a laboratory-type fume hood.

Section 6 – Specialty Classrooms

- ◆ The main hazard in standard painting is accidental ingestion of pigments due to eating or drinking with inadvertent hand-to-mouth contact. If methods such as spraying, heating, or sanding are employed, then there is opportunity for inhalation of toxic pigments.
- ◆ The classic example of a toxic inorganic pigment in painting is white lead, or flake white. Lead pigments can cause anemia, gastrointestinal problems, peripheral nerve damage, kidney damage and brain damage in children. Health effects associated with other inorganic pigments include skin ulceration, skin cancer or lung cancer.

Known or Possible Carcinogens/Highly Toxic Pigments	Moderately/Slightly Toxic Pigments
<ul style="list-style-type: none"> ◆ Antimony white (antimony trioxide) ◆ Barium yellow (barium chromate) ◆ Burnt umber or raw umber (iron oxides, manganese silicates or dioxide) ◆ Cadmium red or orange (cadmium sulfide) ◆ Cadmium yellow (cadmium sulfide) ◆ Cadmium barium colors (cadmium colors and barium sulfate) ◆ Cadmium barium yellow (cadmium sulfide, cadmium selenide, barium sulfate, zinc sulfide) ◆ Chrome green (Prussian blue, lead chromate) ◆ Chrome orange (basic lead carbonate) ◆ Chrome yellow (lead chromate) ◆ Cobalt violet (cobalt arsenate or cobalt phosphate) ◆ Cobalt yellow (potassium cobaltinitrate) ◆ Cobalt violet (cobalt arsenate or cobalt phosphate) ◆ Cobalt yellow (potassium cobaltinitrate) ◆ Lead or flake white (basic lead carbonate) ◆ Lithol red (sodium, barium and calcium salts of soluble azo pigment) ◆ Manganese violet (manganese ammonium pyrophosphate) ◆ Molybdate orange (lead chromate, lead molybdate, lead sulfate) ◆ Naples yellow (lead antimonate) ◆ Strontium yellow (strontium chromate) ◆ Vermilion (mercuric sulfide) ◆ Zinc sulfide (Zinc) ◆ Zinc yellow (zinc chromate) 	<ul style="list-style-type: none"> ◆ Alizarin crimson (lakes of 1,2-dihydroxyanthraquinone or insoluble anthroquinone pigment) ◆ Carbon black (carbon) ◆ Cerulean blue (cobalt stannate) ◆ Cobalt blue (cobalt stannate) ◆ Cobalt green (calcined cobalt, zinc and aluminum oxides) ◆ Chromium oxide green (chromic oxide) ◆ Manganese blue (barium manganate, barium sulfate) ◆ Prussian blue (ferric ferrocyanide) ◆ Toluidine red (insoluble azo pigment) ◆ Toluidine yellow (insoluble azo pigment) ◆ Viridian (hydrated chromic oxide) ◆ Zinc white (zinc oxide)

In addition, the mixing of powdered clay in the classroom, particularly without adequate ventilation, may expose staff and students to large amounts of dust, which may contain silica or

Section 6 – Specialty Classrooms

other contaminants. Exposure can result in respiratory irritation or more serious health concerns with chronic exposure.

6.10.4 *There should be no use or storage of highly toxic solvents.*

Inhalation of almost any solvent can cause some degree of eye, nose and throat irritation as well as central nervous system depression. Intense exposure can result in serious health consequences including cancer and death. MSDSs will identify whether a solvent is highly toxic. Highly toxic solvents include most of the aromatic and chlorinated HCs (toluene, benzene, xylene, styrene, carbon tetrachloride, methylene chloride, ethylene dichloride, perchloroethylene) as well as solvents such as methyl butyl ketone, hexane, methyl cellosolve, phenol and nitrobenzene. There should be adequate supervision when any solvents are being used.

6.10.5 *There should be no use or storage of solvent-based inks or markers that are not Art and Creative Materials Institute (ACMI) approved.*

Use only markers with seal of the Art and Craft Materials Institute:



6.10.6 *Solvents should not be used in elementary classrooms unless an AP label from ACMI is present. Solvents used in secondary education classrooms should be covered or capped during instructional or activity periods and when not in use and should be properly labeled.*

All organic solvents release vapors into the ambient air in a process known as evaporation. Some solvents inherently produce significantly more vapor than others. Keeping containers covered or capped is an effective means of minimizing the amount of solvent vapor that evaporates into the indoor environment. This, in turn, will minimize the inhalation hazard posed by these substances.

When solvents come in contact with the skin, they can dissolve the protective barrier of oils causing burning, irritation and possibly dermatitis. Many solvents form vapors at room temperature and cause irritation of the eyes and respiratory tract. Organic solvents can also be fire and explosion hazards, so should be stored and isolated from sources of heat, sparks, flame and static electricity. It is therefore important that water-based solvents be used in all possible instances, or least-toxic solvents when necessary.

6.11 AEROSOL SPRAYS

6.11.1 *Aerosol sprays should be used under local exhaust systems, while using the appropriate personal protective equipment and under staff supervision.*

The use of aerosol sprays results in the production of mist droplets fine enough to enter the lungs through inhalation. This is more hazardous than simply inhaling solvent vapors, since the spray mists are liquid droplets that contain more solvent. These extremely fine particles can remain in the air where they can be inhaled for up to two hours, even though an odor may no longer be detectable. It is best to avoid spraying whenever possible by using other techniques

Section 6 – Specialty Classrooms

such as dipping or brushing. If spraying is required, it should be done with adequate local exhaust to remove contaminants from the classroom and students should wear a NIOSH-approved respirator with organic vapor cartridges and dust and mist filters. Avoid sprays that use organic solvents whenever possible.

NOTE: Spraying outdoors is not an acceptable alternative as wind speed may not be sufficient, or in the sufficient direction, to carry contaminants away from the student's face. If done near the building, contaminants may be re-entrained into the building through open windows or outside air intakes.

6.12 LOCAL EXHAUST VENTILATION

6.12.1 *Local exhaust systems should be in use when hazardous airborne contaminants are generated as part of classroom activities. Local exhaust systems should be properly maintained in accordance with manufacturer's instructions and inspected annually. Documentation of all maintenance and inspections should be readily available upon inspection.*

An operational chemical fume hood, vented to the outside to at least eight feet above the roof line should be employed where projects are conducted involving the generation of airborne contaminants. The hood(s) should not be within 10 feet of an exit or adjacent to a main aisle. Flow of air should be sufficient to capture contaminants and should flow away from the breathing zone of the student or teacher. If this is not the case, the district should consult a certified industrial hygienist for recommendations

A qualitative assessment of the system may be performed using an air current test plume. Using this method, a visible plume of smoke is released parallel to the face opening of the exhaust device at multiple locations across the face. Slow or uneven movement of the test smoke into the exhaust device across the entire face opening may be interpreted as a preliminary indication of a system deficiency. Such results signal the need for more thorough evaluation.

When metals or their alloys are heated above their melting point, some of the molten metal begins to vaporize. Metal vapors and fumes produced in activities such as soldering, welding, metal casting, jewelry making, kiln firings, and glass blowing, can cause serious acute and chronic health conditions. Students involved in such activities should be closely supervised and local exhaust should be maintained continuously.

6.12.2 *Kilns should have local exhaust systems and should be used under staff supervision.*

Gases produced from kiln firing including chlorine, fluorine, sulfur dioxide, nitrogen dioxide, ozone, carbon dioxide and metal fumes. These gases can cause severe acute or chronic lung problems or more serious health hazards. All kilns, both electric and fuel fired, should be vented directly to the outside by a local exhaust system. General ventilation is usually not sufficient. An overhead canopy is the best choice. Local exhaust fans should be vented directly to the outside at least eight feet ABOVE the building roof line and located at least 50 feet away from any outside air intakes. If this is not the case, the district should consult a certified industrial hygienist for recommendations.

Section 6 – Specialty Classrooms

NOTE: Due to the high temperatures and exposure hazards, kilns should be kept in a separate room to prevent accidental burn injuries.

6.13 EQUIPMENT

6.13.1 Equipment should be in general good repair.

Damaged or defective tools should be repaired or replaced. Tools should be used only in accordance with the intended purpose.

6.13.2 Welding shields or screens should be present, in good repair, and available for use during welding.

Screens or shields should be used to protect students from exposure to sparks and the possibility of flash injury to the eyes.

6.13.3 Guards on blades, belts, or other devices should be operational, secure, and in place when equipment is in use.

Cuts and abrasions are among the most common injuries sustained in shop classes. Belts, shafts, coupling, fan blades and the like should be guarded to prevent entanglement or injury.

6.13.4 Control switches, including emergency shut off switches, should be accessible to any person in the classroom.

Students should be able to reach the power switch for a machine they are using. Should an emergency situation arise or should the student suddenly need to leave the station, they should be able to power off tools or machinery.

6.13.5 Equipment that poses a tipping hazard should be securely anchored.

Portable machinery, mounted on bases, should be locked or blocked to prevent movement or shift while machinery is in operation. Stationary machinery should be secured to prevent walking, moving, or tripping during operation.

6.13.6 Students using machinery or power tools should remove all rings, watches and jewelry while working.

Rings, watches, and jewelry can pose entanglement hazards that could catch and pull a student's body part into a power machine or tool. All accessories that could pose entanglement hazards should be removed and secured during work class periods.

6.14 ELECTRICAL SAFETY

6.14.1 All electrical cords, including extension cords, should be in good condition with no damage or fraying.

Power cords for machinery and hand tools should be in good condition. Machinery or tools with damaged or frayed cords should be removed from use until they are repaired or replaced. In

Section 6 – Specialty Classrooms

addition, electrical cords should not traverse aisles or walkways in such a manner as to pose a tripping hazard.

6.14.2 *There should be no use of ungrounded extension cords or use of extension cords for permanent equipment.*

Industrial arts instructors should provide and allow use of only heavy duty, grounded extension cords for temporary use and portable insulated strips with overload protection for extended situations. If a cord is damaged, it should immediately be removed from use and repaired or replaced. Extension cords should not be used in lieu of permanent wiring.

6.14.3 *Electrical switches and electrical outlets should be in good repair.*

Switches and outlets should be covered, functional, and allow for grounded cords.

REFERENCES

GENERAL SAFETY

1. *Science and Safety-Making the Connection*, Education Resources Information Center (ERIC), <http://www.eric.ed.gov/home.html> (9-9-04)
2. *Building Successful Programs to Address Chemical Risks in Schools: Recommendations from an Evaluation of Selected Schools Chemical Management Programs*, U.S. Environmental Protection Agency, <http://www.epa.gov/epaoswer/osw/consERVE/clusters/schools/pdfs/recommend.pdf> (8-14-07)

MERCURY

3. *National Alert – A Warning About Continuing Patterns of Metallic Mercury Exposure*. Agency for Toxic Substances and Disease Registry (ATSDR), <http://www.atsdr.cdc.gov> (9-9-04)
4. Mercury (Web site), U.S. Environmental Protection Agency, <http://www.epa.gov/mercury/index.htm>. (5-5-05)

CHEMICAL SAFETY

5. *Hazardous Chemical Storage* (Web site), Flinn Scientific, Inc. <http://www.flinnsci.com/Sections/Safety/chemicalSafety/hazardousStorage.asp> (5-5-05)
6. *Chemical Hygiene Plan (OP-G-1.5.1)* (Web site), Florida State University <http://www.safety.fsu.edu/chp.html#appendix5> (6-15-05)
7. *Storage and Use of Flammable and Combustible Liquids* (Web site), University of North Carolina, Department of Environmental Health & Safety <http://ehs.unc.edu> (6-15-05)

Section 6 – Specialty Classrooms

8. *Hazardous Waste*, U.S. Department of Labor Occupational Safety and Health Administration, <http://www.osha.gov> (8-14-07)
9. *Hazardous Waste*, Air and Waste Management Association (AWMA), <http://www.awma.org/index.html> (8-14-07)
10. *Hazardous Materials*, National Clearinghouse for Educational Facilities (NCEF), <http://www.edfacilities.org/index.cfm> (8-14-07)
11. *School Chemistry Laboratory Safety Guide*, Centers for Disease Control and Prevention, <http://www.cdc.gov> (8-14-07)
12. *Biological and Chemical Safety in Schools*, The Center for Health and Health Care in Schools, <http://www.healthinschools.org/> (8-14-07)
13. *Waste and Recycling*, U.S. Environmental Protection Agency, <http://www.epa.gov/highschool/waste.htm> (8-14-07)
14. *Toxic Substances and Your Environment*, Centers for Disease Control and Prevention, <http://www.cdc.gov/Environmental/> (8-14-07)

ADDITIONAL RESOURCES

The following Internet sites and software are excellent sources for information on science safety:

Gerlovich, Jack A., et al. Total Science Safety System Software. JaKel, Inc., 1998. JaKel, Inc. Online Information Site:

<http://www.netins.net/showcase/jakel>

Kaufman, Jim. The Laboratory Safety Institute. Online Information Site:

<http://www.labsafety.org>

Section 7 – Auditoriums & Student Dining Areas

7.1 GENERAL SAFETY & HOUSEKEEPING

7.1.1 *Portable banquet tables, cafeteria tables and other portable furniture items, when not in a position intended for use, should be stored in a manner that is inaccessible to students or should be secured to the wall or floor to prevent injuries from tipping. Heavy furniture items should be moved only by authorized personnel.*

Cafeteria tables that fold up and are mobile should not be stored unsecured around children. There are documented cases where children have been killed or seriously harmed when these tables have fallen on them. A warning label should be affixed to these types of tables to indicate the danger of tip-over when these tables are in the upright position. Mobile tables should be stored secured to the wall in a manner that will prohibit possible tip over or in a storage room that is inaccessible to students. More information on these tables can be requested from the U.S. CPSC.

7.1.2 *The cafeteria tables should be cleaned and sanitized between each use.*

Cleaning tables between use is an integral part of effective environmental hygiene in the school environment. Studies have shown that cold and flu germs are able to survive on, and be transferred from, many commonly touched surfaces for up to 48 hours. Effective cleaning of any food residue will also contribute to integrated pest management.

7.1.3 *Floors should be cleaned after spills and after periods when food is served.*

Cafeteria tables should be cleaned after lunch periods to discourage pests and promote a sanitary environment. The cleaning solution used to clean the tables should be approved and provided by the school district. The floors in the cafeteria should also be cleaned after lunch periods and other events when food is served. When spills occur, they should be promptly cleaned to prevent slipping and to discourage pests.

REFERENCES

AUDITORIUMS AND STUDENT DINING AREAS

1. *Food Service Facilities*, National Clearinghouse for Educational Facilities (NCEF), <http://www.edfacilities.org/index.cfm> (8-14-07)

Section 8 - Library/Media Center

8.1 HOUSEKEEPING

8.1.1 *There should be no accumulation of dust, suspected mold, or other material on books or shelves.*

Dust is a known allergy and asthma trigger and readily accumulates in nooks and crannies. Therefore, it is important book shelves in a library are dusted regularly to prevent the buildup of dust on books and shelves. Mold will grow readily on paper. The humidity levels in the library should be kept within the range indicated in the table in section 5.8.2. Routine visual inspection of these surfaces and prompt attention to a problem when discovered should help in preventing issues with mold and dust from occurring. For more information on mold and mold cleanup, please refer to section 5.1.1.

8.2 GENERAL SAFETY

8.2.1 *Televisions and heavy equipment that may pose a hazard by tipping or falling should be securely anchored to a cart, wall, or floor and should be moved only by authorized personnel.*

Carts are commonly employed in schools to hold televisions and computer monitors for better classroom viewing by students. Unfortunately, such assemblies are inherently unstable due to their high centers of gravity. The use of anchoring bolts or straps will prevent the TV or other equipment from falling off of the cart in the event of tipping – potentially injuring nearby students. Note, however, that the addition of such anchors does nothing to lower the inherent instability in the assembly.

The addition of weight, in the form of sandbags or other dense material, to the base of the cart (near the wheels) is one way to effectively lower the centers of gravity for such assemblies. However, this will add significantly to the overall weight of the assembly making the unit more difficult to move.

8.2.2 *Shelving should be secured so that free standing or mobile shelving should not pose a tip-over hazard and should be moved only by authorized personnel.*

The height, depth, and weight distribution of a given bookcase will determine its center of gravity and inherent stability. Because unstable bookcases may fall on nearby students and staff, such units should be physically anchored to prevent tipping.

REFERENCES

LIBRARY/MEDIA CENTER

1. *Library and Media Center Facilities Design*, National Clearinghouse for Educational Facilities (NCEF), <http://www.edfacilities.org/index.cfm> (8-14-07)

Section 9 – Indoor Athletic Facilities

INTRODUCTION

Physical education is required to be taught in all public schools in Ohio. Schools throughout Ohio offer opportunities for students to participate in sporting activities. High school students are required to take physical education in order to graduate. Because of the requirement for physical education and the potential for students to become injured, the inspection of the school gymnasium should not be overlooked when doing school inspections. The December 2001 *MMWR* report published by the CDC states, "In the United States, approximately 8 million high school students participate in school- or community-sponsored sports annually. Approximately 1 million serious sports-related injuries (i.e., injuries resulting in hospitalization, surgical treatment, missed school, or one-half day or more in bed) occur annually to adolescents aged 10-17 years, accounting for one-third of all serious injuries in this age group. From 1996 to 1998 in Washington, D.C., approximately 5 percent of the adolescent population visited a hospital emergency department because of sports-related injuries. Sports cause approximately 55 percent of nonfatal injuries at school. Each year, approximately 300,000 mild to moderate traumatic brain injuries are classified as sports-related."

9.1 ATHLETIC EQUIPMENT

9.1.1 All gym equipment and associated loose furnishings should be safe, sanitary, and in good repair.

Protrusions or projections on physical education and/or sports training equipment should not be capable of entangling a student's clothing or cutting or puncturing a student's skin. Clothing entanglements can cause death by strangulation. Jewelry (necklaces), jackets and sweatshirts with hoods and/or drawstrings have been involved in such entanglement/strangulation incidents. All physical education and sports training equipment should be in proper working order to prevent injuries to those using the equipment.

Exercise mats are designed to give participants a softer surface to perform their sport or exercise and to provide protection from injury when coming into contact with a harder surface (floor, wall). It is imperative that these exercise mats maintain the proper padding and shock absorbency to prevent injury upon impact. Mats that are torn or have holes should be replaced because the exposed padding in the mat can harbor bacteria, viruses and fungi from the body and potentially pose a threat to other users. If the mats can be repaired without the integrity and purpose of the mat being compromised, that is acceptable.

9.1.2 Cleaning supplies should be readily available for use under staff supervision.

Exercise mats and equipment in gymnasiums and training rooms may come into contact with sweat and at times blood. When exercise equipment or mats come in contact with blood, use of the equipment or mat should cease and the equipment or mat disinfected immediately in accordance with the blood-borne pathogen policy found in section 18.3.3.3. To help prevent the transmission of bacteria, viruses, and fungi [including methicillin-resistant *Staphylococcus aureus* (MRSA)] from one user to the next, these pieces of equipment should be cleaned and disinfected between users and/or after events.

Please see the appendix for specific information on MRSA for coaches and athletes.

Section 9 – Indoor Athletic Facilities

9.1.3 *Appropriate floor matting should be provided.*

Protective padding in a gymnasium is generally thought to protect basketball players from injury, but protective padding is also useful for other activities, such as rope/wall climbing, gymnastics, wrestling and physical education activities. ASTM specification F 2440-04, section 7.1 states, "Wall padding is normally produced in sections that are assembled prior to use. The padding should be installed such that these sections are fastened securely together to prevent them from becoming separated during use. (Warning-Areas of padding missing coating or covering are considered health hazards)."

Section 8 of the same specification states, "Padding should be used on walls and other facility features in or around the playing area that an athlete might contact during play. The length and width dimensions of the mats should be appropriate to provide protection for that area. Padding is typically installed no more than 4 inches from the floor up to 6 ft."

The preceding ASTM sections were extracted, with permission, from F2440-04 Standard Specification for Indoor Wall/Feature Padding, copyright ASTM International, 100 Barr Harbor Drive, West Conshohocken, PA 19428. A copy of the complete standard may be obtained from ASTM (<http://www.astm.org>).

9.2 BLEACHERS & TELESCOPIC SEATING

9.2.1 *The school should have all bleachers, folding and telescopic seating, and grandstands inspected at least once annually by a qualified person. Qualified person as used in this paragraph means an individual familiar with the design, installation, operation, and maintenance of folding and telescopic bleachers and grandstands. Documentation of annual inspections should be available to the sanitarian at the time of the school inspection.*

Under Section 1024.1.1 of the OBC (OAC 4101:1), school districts are required to comply with the ICC Standard on Bleachers, Folding and Telescopic Seating and Grandstands (ICC-300) for new and existing temporary and permanent bench bleachers, folding and telescopic seating and grandstands. Note that the inspection items included herein constitute only a portion of the requirements included in ICC-300. Therefore, compliance with this section does not ensure compliance with the entirety of ICC-300. An initial inspection should be conducted to evaluate compliance with the manufacturer's installation and operational instructions including an inspection during the opening and closing of such seating and should be conducted annually, thereafter.

9.3 INDOOR AQUATIC FACILITIES

9.3.1 *Indoor aquatic facilities should be in compliance with the requirements in Chapter 3701-31 of the Administrative Code.*

Chapter 3701-31 contains the administrative rules governing the operation of public swimming pools and spas.

Section 9 – Indoor Athletic Facilities

9.4 LOCKER ROOMS**9.4.1 *Hot and cold running water should be supplied to all faucets and showers that are operational.***

There are many types of diseases transmitted through lack of good hygiene. Good hygiene is promoted through supplying hot and cold water to showers and faucets. All showers used by the students and/or staff should be maintained with hot and cold running water. Section 607.1 of the OBC requires, "In occupied structures, hot water should be supplied to all plumbing fixtures and equipment utilized for bathing, washing, culinary purposes, cleansing, laundry, or building maintenance. Tempered water should be delivered from public hand-washing facilities." Hot water is defined as "Water at a temperature greater than or equal to 110° F." Tempered water is defined as "Water having a temperature range between 85° F to 110° F."

9.4.2 *Restroom facilities should comply with the requirements outlined in Section 10.1 of this manual.***9.4.3 *There should be no evidence of sustained water condensation, water intrusion, water damage or suspected mold on any surface.***

Mold and mildew grow on wet surfaces. Mold may exacerbate allergy or asthma symptoms in sensitive individuals. Whenever mold or mildew is visible on surfaces in locker rooms, the underlying moisture source supporting it should be identified and mitigated and the mold should be removed. An example of mitigating a moisture source is installation and maintenance of exhaust fans to remove water vapor at its source.

When paint is properly applied to a surface, it should not peel. High humidity in locker rooms, mostly due to the steam from the showers, may lead to paint failure more rapidly than areas of lower humidity. All peeling paint should be stabilized to prevent further peeling and flaking. For school buildings built before 1978, refer to section 5.3.1 for more information on paint stabilization.

9.4.4 *Operational showers should not be used for storage.*

Showers and shower areas are generally large open spaces. In schools where the showers are provided, but are not used, shower areas are often used for storage. If the showerheads in these areas are supplied with water, there is a potential for storage items to get wet. If the items become wet, mold can quickly grow and become a problem. It is important that shower areas not be used for storage unless the water has been turned off to the showerheads. In this case, floor drains should also be capped off to prevent sewer gas intrusion. When a decision has been made to change the use of the shower area from showering to storage, a change-of-use request should be processed by the local building department and approved prior to the implementation of the change.

9.4.5 *Operational showers used by students should have non-slip mats or non-slip surfacing in the vicinity of showers where wet floors may pose a slip hazard.*

No-slip surfaces help prevent slip hazards in wet conditions.

9.4.6 *Non-operational showers used for storage should be clean, sanitary and supplied with a non-operable water source and drains that prevent infiltration of sewer gas.*

Section 9 – Indoor Athletic Facilities

9.4.7 *Drain traps servicing floors, sinks, and toilets should contain sufficient water to prevent the migration of sewer gas into the indoor environment.*

When drains become dry, sewer gases can escape and release odors into the environment. When drains are functioning properly, water acts as a seal in the trap to prevent sewer gas from entering the enclosed space. Drain traps in floors, sinks, and toilets should be checked for the presence of water routinely. If there is a time of year when these areas are not used frequently, water should be poured down the drains seal the traps.

9.5 TRAINING & WEIGHT ROOMS**9.5.1** *Weightlifting equipment and benches should be sanitary and in good repair.*

Weight lifting equipment that is poorly maintained could cause injury to the user. Equipment should be evaluated monthly to determine proper working order and any repairs to equipment should be made promptly. Weight benches should be disinfected between uses. Bench covers that become worn or torn should be repaired to prevent contamination of the padding. Bodily fluids will readily absorb into the unprotected padding and possibly transmit microorganisms to other users.

9.5.2 *Therapeutic whirlpools should be sanitary, in good repair, and the area should be equipped with an operable exhaust fan.*

Whirlpools that are used for therapeutic purposes under the supervision of a person certified by the State Medical Board are not required to be licensed by the State of Ohio. Generally the person in the school setting certified by the State Medical Board is the athletic trainer. Therapeutic whirlpools are single-use pools used for limited amounts of time, generally no more than 20 minutes. After each use, the whirlpools should be rinsed, cleaned and disinfected. The disinfectant used could be a bleach solution or any other disinfectant approved by the State Medical Board and supplied by the local school district. The water temperature for the whirlpool should not exceed 104⁰F. The whirlpools should be plugged into a ground fault circuit interrupter (GFCI) outlet.

The room in which the whirlpool is being utilized will often be steamy and have a higher humidity level than the other athletic rooms. It is recommended that these areas be equipped with their own operable exhaust fan to remove steam and moisture. Removing steam and moisture in an efficient manner will help prevent mold from growing in these areas.

9.5.3 *Cleaning supplies should be readily available for use under staff supervision and used to clean and sanitize equipment after use by each individual.*

Weight benches should be disinfected between uses in order to prevent transmission of bacteria, fungi, and viruses among athletes including MRSA. Disinfectant solutions should be used between uses and under supervision, if used by students.

Section 10 - Restrooms

10.1 SINKS & PLUMBING FIXTURES

10.1.1 *All plumbing fixtures should be sanitary, operable, properly supplied, and in good repair.*

To ensure proper sanitation and good hygiene, plumbing fixtures in restrooms need to be working properly. Leaky plumbing can allow mold to grow and attract pests. Fixtures that become broken or inoperable should be fixed immediately to prevent mold growth and pest infestations and to allow for proper hygiene.

All drains should be able to receive all water and waste into the sanitary sewer system. When drains become clogged, they can overflow onto the floor creating an unsanitary environment. When using chemical drain cleaners, follow manufacturer's instructions and prevent student exposure.

10.1.2 *Sinks supplied by automatic or low-flow fixtures should provide a continuous flow of water for at least ten seconds.*

Hand washing is the single most important behavior in preventing the spread of infectious disease. Proper hand washing requires continuous flow of water for lathering for approximately 20 seconds, or longer if necessary. Proper hand washing is essential in preventing the transmission of germs and illness from person to person. Automatic sinks reduce the amount of contact necessary with the sink surface, which also promotes proper hand cleaning.

10.1.3 *Hand washing sinks should be provided with hand cleaning liquid, powder, or bar soap and individual, disposable towels, continuous towel system that supplies the user with a clean towel, or a heated-air hand drying device.*

Sinks collect dirt and bacteria from our bodies. Sinks should be kept clean to limit bacterial growth on the surfaces. An all-purpose bathroom cleaner, approved and provided by the school district, should be sufficient to clean all surfaces of the sink including the underside.

10.1.4 *Tempered water should be available at all sinks.*

There are many diseases that are transmitted through lack of good hygiene. In order to encourage people to wash their hands, the temperature of the water should be comfortable. Section 607.1 of the OBC requires, "In occupied structures, hot water should be supplied to all plumbing fixtures and equipment utilized for bathing, washing, culinary purposes, cleansing, laundry or building maintenance. Tempered water should be delivered from public hand-washing facilities." Tempered water is defined as "Water having a temperature range between 85° F to 110° F."

10.1.5 *Hand-washing posters should be visible from all sinks.*

Improper hand washing is a major contributor to the spread of infectious diseases. To remind students and staff to wash their hands and wash them correctly, a hand washing poster should be visible from all sinks designated for hand washing. Two examples of hand washing posters are shown below. Hand washing posters are available for download from the Internet,

Section 10 - Restrooms

including the CDC Web site (<http://www.cdc.gov>). Hand washing posters should include information about using soap and about how and how long to wash hands.



10.1.6 Toilet tissue should be available at each toilet.

Toilet paper should be provided in each toilet stall to promote good hygiene. Toilets should be kept clean to prevent the spread of disease. An all-purpose bathroom cleaner should be sufficient to clean all surfaces of the toilets and urinals including the underside. Toilets and toilet seats should be constructed of materials that are easily cleanable. Toilets seats should be secured and maintained intact to prevent injury.

10.2 HOUSEKEEPING

10.2.1 Floors should be clean and dry.

Soiled floors are unsanitary and promote the spread of disease. Staff or students who walk on contaminated floors may spread contamination throughout the building. The floors in the restrooms should be cleaned daily or more frequently, as needed. Restroom floors should also be kept dry to prevent slipping or falling. Any leaky plumbing should be promptly repaired. When the floor becomes wet, proper signage should be placed.

10.2.2 Adequate waste receptacles should be conveniently located.

A waste receptacle should be kept next to or in close proximity to the hand wash sinks wherever disposable towels are used to dry hands. Covered waste receptacles should be provided in all girls restrooms.

Section 10 - Restrooms

10.3 EXHAUST FANS

10.3.1 *Exhaust fans should be operable and continually operating while the building is occupied.*

Restrooms are the source of a various odors. Strong odors can cause health complaints or serve as an asthma trigger for sensitive individuals. Exhaust fans should run continuously throughout the school day to remove contaminants and eliminate odors. Excessive odors could be an indication that the ventilation system in the restrooms is not working properly. Excessive odors may also be an indication of malfunctioning plumbing. All toilets should flush adequately so that all sewage is disposed, all sinks should drain properly and floor drains should not be clogged. To prevent odors from being circulated into the building, the exhaust fans should be vented directly to the outside and should be located away from outside air intakes.

10.4 DIAPERING FACILITIES

10.4.1 *Diapering facilities should be sanitary and in good condition. Elevated diapering facilities should be properly guarded to prevent falls.*

Diapering facilities should be clean and free of debris to prevent the transmission of illness. Ensuring they are also in good repair is essential to preventing unnecessary injury due to falling. Diapering facilities should be regularly inspected to make certain that all equipment is safe and in good repair.

REFERENCES**RESTROOMS**

1. *Healthy Schools, Healthy People*, School Network for Absenteeism Prevention (It's a SNAP), <http://www.itsasnap.org/index.asp> (8-14-07)
2. *Clean Hands Save Lives!*, Centers for Disease Control and Prevention, <http://www.cdc.gov/cleanhands/> (8-14-07)
3. *Clean Hands Campaign*, American Society for Microbiology, <http://www.washup.org/index.html> (8-14-07)
4. *An Ounce of Prevention Keeps the Germs Away*, Centers for Disease Control and Prevention, <http://www.cdc.gov/ounceofprevention/> (8-14-07)

Section 11 - Custodial Closets

11.1 GENERAL SAFETY & SECURITY

11.1.1 The custodial closet should be inaccessible to unauthorized individuals.

Many of the chemicals and supplies commonly found in the custodial closet pose fire, safety, and health hazards to students. Such chemicals may also represent an attractive nuisance to students inclined toward their misuse. Access to all custodial closets should be restricted and doors kept locked while not physically occupied by school custodial staff.

Such controls will significantly reduce the likelihood of accidental chemical exposures, other accidents, or intentional misuse by students.

This section does not supersede the OBC, section 1008.1.8 which requires all egress doors to be readily opened from the egress side without the use of a key or special knowledge or effort.

11.2 SINKS

11.2.1 All sinks should be equipped with backflow prevention devices.

Faucet spouts on custodial sinks are often outfitted with hoses to minimize splashing and facilitate bucket filling. However, such a configuration constitutes a serious water-supply contamination hazard due to the potential siphoning that can occur within the plumbing distribution system. Should the open end of faucet-mounted hoses become immersed in liquid contained in either the sink or a bucket – such contaminant liquids may be inadvertently sucked into the water supply system, posing a water-contamination hazard for the entire system.



11.3 HAZARD COMMUNICATION

11.3.1 All containers of chemicals should be properly labeled.

Refer to section 8.8.1 for more information.

11.3.2 Material data safety sheets (MSDSs) should be readily accessible to staff for all hazardous chemicals used or stored in the custodial closet.

Refer to section 8.8.2 for more information on MSDS.

Section 11 – Custodial Closets

11.4 CHEMICAL STORAGE**11.4.1 *All flammable or combustible liquids should be stored in approved flammable storage cabinets.***

There should be requirements in place to control flammable or combustible liquids in order to protect school attendees, personnel and the environment. These liquids should be stored in accordance with the International Fire Code and the amount of liquids stored should be limited to the amount required for the operation of office equipment, maintenance, demonstration, treatment, or laboratory work. Only approved containers and/or tanks should be used to store flammable or combustible liquids.

REFERENCES

CHEMICAL STORAGE

1. *Chemical Management Resource Guide for School Administrators*, U.S. Environmental Protection Agency (8-23-07)
2. *Codes and Standards*, National Fire Protection Association, <http://www.nfpa.org/>, (8-23-07)

Section 12 - Mechanical Rooms

12.1 GENERAL SAFETY & SECURITY

12.1.1 All doors to the mechanical room should be locked.

To prevent access to the mechanical room by unauthorized individuals, the door should be equipped with an operable lock. The door to the mechanical room should be kept locked when not occupied by facilities/maintenance staff. Mechanical rooms, by their function, contain machinery and chemicals that pose serious potential hazards to outside students or staff.

This section is not meant to be in conflict with the OBC, section 1008.1.8 which requires all egress doors to be readily opened from the egress side without the use of a key or special knowledge or effort.

12.1.2 Floors should be free of slip, trip, and fall hazards.

Mechanical rooms typically house equipment including boilers, condensers, steam traps, etc. that release water in small quantities. This water should drain directly to floor drains which should be inspected frequently to ensure water is draining effectively to the drainage system. Water on the floor could cause a person to slip and fall.

In addition to water, oil leaks from machinery or spills during maintenance and repair activities constitute another slip/fall hazard in the mechanical room.

It is also important to ensure these rooms remain free from general obstructions (boxes, crates, portable equipment, etc.) to ensure free and safe passage through the space.

12.2 CHEMICAL STORAGE

12.2.1 All flammable or combustible liquids should be stored in an approved flammable storage cabinet.

There should be in place requirements to control flammable or combustible liquids in order to protect school attendees, personnel and the environment. These liquids should be stored in accordance with the International Fire Code and the amount of liquids stored should be limited to the amount required for the operation of office equipment, maintenance, demonstration, treatment or laboratory work. Only approved containers and/or tanks should be used to store flammable or combustible liquids.

12.3 HOUSEKEEPING

12.3.1 There should be no storage of items that inhibit or restrict routine maintenance or cleaning.

Mechanical rooms house the HVAC equipment and other large machinery. Because the HVAC equipment is what moves and circulates the air, it is important that these rooms remain clean so nothing harmful is introduced into the ventilation system. Any item that restricts or inhibits cleaning in these areas should be removed. All storage containers should be able to be easily cleaned and moved when necessary.

12.4 WATER TREATMENT SYSTEMS

- 12.4.1** *If a school or school district owns, operates, or manages the drinking water or waste water systems for a school building, the school or school district should be in compliance with any applicable regulations of the Ohio Environmental Protection Agency and the Ohio Department of Health and should provide documentation of compliance to the sanitarian upon inspection.*

REFERENCES

CHEMICAL STORAGE

1. *Chemical Management Resource Guide for School Administrators*, U.S. Environmental Protection Agency (8-23-07)
2. *Codes and Standards*, National Fire Protection Association, <http://www.nfpa.org/>, (8-23-07)

Section 13 - Health Care Areas

The school health clinic is an area in the school building where the health needs of students are appropriately addressed. Privacy and confidentiality should be provided to students seen at the health clinic. The variety of services offered in the school health clinic requires that the facilities be equipped with basic first aid supplies. To avoid the spread of disease, the clinic should be thoroughly cleaned daily or more often when necessary. The cleaning solution should clean and sanitize the surfaces in the health clinic.

This guidance provides basic recommendations of supplies and equipment that should be present in every school health clinic. “While health centers may range from a cot and first-aid station to a comprehensive clinic offering physical, behavioral and mental health services to students and their families, all health facilities should guarantee privacy, confidentiality and a sense of well being.”¹

13.1 GENERAL

13.1.1 *A toilet and sink adjacent to the area and not used by the general student population.*

Toilet facilities, which are handicapped accessible either should be in the health clinic or immediately adjacent to it. It is critical that ill persons in the school building be able to quickly reach these facilities, where privacy is available and monitoring by the nurse or responsible adult can be provided.

Refer to section 10.1 for additional information on hand wash sinks.

13.1.2 *A cot and mattress with waterproof cover.*

Ideally, the cot for resting should be placed in a quiet, private area in the clinic where the ill or injured student can be observed by the nurse or responsible adult. The cot and mattress should be easily cleanable. The mattress cover should be waterproof and disinfected between uses by students. All bedding used on the cot either should be disposable or washed between student uses.

13.1.3 *Access to a telephone.*

A telephone should be installed in all clinics to facilitate communication in the event of an emergency.

13.1.4 *Locked storage for medications as required by section 3313.713 of the Revised Code, except when other law allows for the carrying and self administration of medication by the student.*

ORC Section 3313.713 requires that all medications “should be stored in a locked storage place, except that drugs that require refrigeration may be kept in a designated medication refrigerator that is not used for other purposes.” The exception to this requirement is cited in ORC 3313.713, which allows students to carry their own asthma inhalers as long as the defined procedures are followed.

Section 13 – Health Care Areas

13.2 EQUIPMENT & DURABLE SUPPLIES

The following items should be present in all school clinics. Some additional items to those listed below that you might recommend are a wheelchair, blunt scissors or tweezers, and a pen light or flashlight with extra batteries.

13.2.1 A current first aid reference document.

Each health clinic should have this reference book available to staff in case a nurse is not present during an emergency.

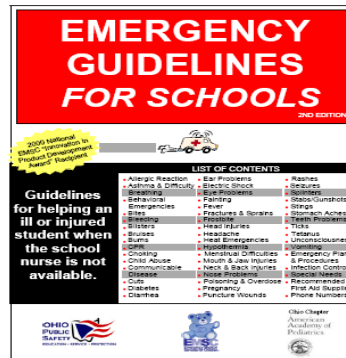
**13.2.2 A sharps container when sharps disposal is necessary.**

Any time syringes or other sharps are used in the school environment, a properly identified sharps container should be available to safely store used sharps. The contents of the sharps container should be properly disposed of and sealed in designated biohazard containers.

13.2.3 A non-mercury containing thermometer. When sphygmomanometers are present they should be non mercury containing.

Mercury-containing thermometers and sphygmomanometers (used for measuring blood pressure) should not be used due to the high potential for exposure to mercury when thermometers and sphygmomanometers are broken. There are alternatives to mercury thermometers and sphygmomanometers that can be used in the school environment. Alcohol-based thermometers and aneroid sphygmomanometers may be used because these are mercury free.

First aid supplies should always be available and accessible to staff in the event of an emergency. Supplies should be adequate to meet the needs of the school's population. A list of supplies is included in the Emergency Guidelines for Schools book. This list is not all inclusive, nor required, but can be used as a guide.

EXPENDABLE SUPPLIES (Recommended)

- Cotton-tipped applicators
- Assorted bandages and dressings
- Cotton balls

Section 13 – Health Care Areas

- Splints
- Cold pack or ice
- Triangular bandages for sling
- Tongue blades
- Seventy percent Isopropyl alcohol (if indicated for cleaning thermometer)
- Safety pins
- Soap
- Disposable facial tissues
- Paper towels
- Disposable gloves (vinyl)
- Pocket mask/face shield for CPR
- Emergency tooth preserving system such as Hank's Balanced Salt Solution (HBSS) or 1/3 cup of powdered milk (for mixing with water to make a liquid solution)
- Bleach or EPA-approved tuberculocidal solution (or agent that will kill hepatitis B)

Section 14 - Administrative Areas

14.1 BREAK ROOMS

14.1.1 *All appliances used in a break room should be clean and in good repair.*

Appliances, surfaces, and any area where food is prepared should be kept clean in order to prevent disease transmission and to prevent the attraction of pests. Refrigerators should be kept clean and contain a thermometer so it is easy to see if it is being maintained at an appropriate temperature to prevent spoilage of food. Non-food items should not be stored in a refrigerator used for food storage.

14.1.2 *All food in break rooms should be properly stored to limit attraction of pests. Refrigerators in break rooms should not be used for storage of chemicals or specimens.*

Food attracts insects and rodents into the indoor environment. All perishable foods should be stored in sealed containers or in the refrigerator.

Section 15 – EH & Safety Management Policies

Each school building administrator should have, available upon inspection, administrative rules or protocols regarding the following topics:

- 15.1** ***RADON TESTING.** The school should have a radon rule or protocol and evidence that the school has been built radon resistant or has been tested for radon within the past five years.*

New school buildings should be built radon-resistant using radon resistant construction techniques. Older buildings and those not built radon resistant should be tested for radon every five years. Radon is a naturally occurring gas that enters buildings from the surrounding soil. It is colorless, odorless, tasteless, and radioactive. Elevated levels of radon have been found in homes and schools across Ohio. Increased radon levels increase the risk of lung cancer in humans. Radon is the second-leading cause of lung cancer in the United States, second only to tobacco smoking.

- 15.2** ***SCHOOL-WIDE SAFETY OR CRISIS MANAGEMENT PLAN** in accordance with section 3313.53.6 of the Revised Code which provides a protocol for responding to any emergency events that do occur and that compromise the safety of school property, students, employees, or administrators and that includes providing immediate notification to the appropriate fire department and board of health in the event of any spill or release of a hazardous substance on school grounds.*

Ohio school boards are required to adopt a comprehensive school safety plan for each school building under its control. ORC Section 3313.536 requires that the plan incorporate a protocol for addressing serious threats to the safety of school property, staff and students as well as a protocol for the emergency response to any events which can compromise the safety of school property, students or staff. The school board is required to file a copy of the safety plan with the law enforcement agency that has jurisdiction over the school building.

For additional information, contact the Ohio Department of Education, Safe and Drug Free Schools Program, at 614-466-6830, or the Ohio Resource Network for Safe and Drug Free Schools and Communities at 1-800-788-7254 (Opt #2) or <http://www.ebasedprevention.org>.

- 15.3** ***BLOODBORNE PATHOGENS** guidance in accordance with Chapter 4167. of the Revised Code.*

If any employee could be exposed to blood while conducting regular job duties (i.e., nurses, coaches, etc.), the school should have a blood-borne pathogen policy and an exposure control plan. For further information, schools may contact the Ohio Public Employee Risk Reduction Program at 1-800-671-6858.

- 15.4** ***Medications** in accordance with section 3313.713 of the Revised Code.*

Section 3313.713 requires schools to have a policy on the administration of prescribed drugs. For further information, schools may contact ODH, School and Adolescent Health Services at 614-466-5332.

Section 15 – Administrative Policies

15.5 HAND WASHING PROTOCOL. Each school should have a rule or protocol on hand washing which should be implemented in each school.

Keeping hands clean is one of the simplest and most effective methods for preventing the transmission of common colds, influenza, and food-borne illnesses. Hand washing facilities need to be conveniently accessible to students and staff and their frequent use encouraged by school staff members. The prospect of a major pandemic of flu raises the importance of routine hand washing at school. However, the evidence suggests that good hand hygiene is not routinely practiced in many schools.

An appropriate hand washing policy will include:

- Commitment to promote hand washing by administration
- Methods by which school occupants will be instructed on appropriate technique
- Statement on when or in what circumstances building occupants will be encouraged to wash hands
- Posting of hand washing posters

15.6 NO SMOKING SIGNS posted in accordance with Chapter 3794 of the Revised Code.

As a result of the passage of Issue 5 on the Nov. 7, 2006, ballot, Ohio became the 12th state to protect all workers and the public from exposure to secondhand smoke in workplaces and public places, including schools.

In accordance with section 3794.06 of the Revised Code, "No Smoking" signs or the international "No Smoking" symbol (consisting of a pictorial representation of a burning cigarette enclosed in a red circle with a red bar across it) should be conspicuously posted, by either affixing to real property or posting by other means, in every public place and place of employment where smoking is prohibited by Chapter 3794. of the Revised Code, including at each entrance to the public place or place of employment.

All signs are required by section 3794.06 of the Revised Code to contain the telephone number 1-866-559-OHIO (6446) for reporting violations and may also contain a designee's telephone number for reporting violations.

Signs should be of sufficient size to be clearly legible to a person of normal vision throughout the areas they are intended to mark.

Signs posted in public places and places of employment should be posted at a height and location easily seen by a person entering the public place or place of employment.

Signs posted in vehicles should be firmly affixed to the vehicle dashboard, or firmly affixed to each passenger door window, or firmly affixed to other areas visible to all passengers.

Signs should be posted at all pedestrian points of transition from areas where smoking is not regulated by Chapter 3794. Of the Revised Code or this chapter to all areas that are regulated. Nothing in this rule should prohibit public places and places of employment from posting signs in addition to those required to comply with Chapter 3794 of the Revised Code.

15.7 *INTEGRATED PEST MANAGEMENT PLAN (IPM). Schools should have a written IPM plan that includes identification of pests and conditions that attract pests; prevention techniques such as sanitation, vacuuming, structural repair and sealing; monitoring; education and training; approved least toxic chemical use only as a last resort; and pre-notification of chemical use.*

The goal of the school IPM program is to protect human health by suppressing pests that cause diseases, to reduce losses from pest damage, reduce environmental pollution, reduce human exposure to pesticides, particularly that of children and to reduce costs of pest control. In IPM programs, treatments are not made according to a fixed schedule; they are made only when and where monitoring has indicated that the pest will cause unacceptable economic, aesthetic or medical injury or damage. In an IPM program, if treatments are needed, they are selected and timed to be most effective on the pest, least disruptive to its natural control and least hazardous to humans and the environment.

An IPM program is built around the following components: monitoring the pest populations and other relevant factors; accurate identification of the pest; determining injury and action levels that trigger treatments; timing treatments to the best advantage; spot treating the pest (to minimize human and other nontarget organism exposure to pesticides); selecting least-disruptive tactics; evaluating the effectiveness of treatments to fine-tune future actions; and educating all people involved with the pest problem.

There are five treatment options under the IPM plan, which are: 1) education; 2) pest habitat modification (i.e., design or redesign of structures and landscape plantings, improved sanitation, eliminating water sources for pests and eliminating the pest habitat); 3) physical controls (i.e., vacuuming, trapping, erecting barriers, controlling the indoor climate, and removing pests by hand); 4) biological controls; and 5) least-toxic chemical controls.