

**Norwood Township Agenda
Special Meeting April 1, 2024 6pm**

Join Zoom Meeting

<https://us06web.zoom.us/j/82231266461?pwd=ZbczueoJRklRUR3bYd3keyFk6Hpjhn.1>

Meeting ID: 822 3126 6461

Passcode: 313262

Call to Order

Pledge of Allegiance

Roll Call

Approval of Agenda –

Old Business: Park Pavilion Design, Quote and Placement

Correspondence/Announcements

Public Comment – Individuals wishing to speak under Public Comment need to state name and where they live – Thank you!

Adjournment

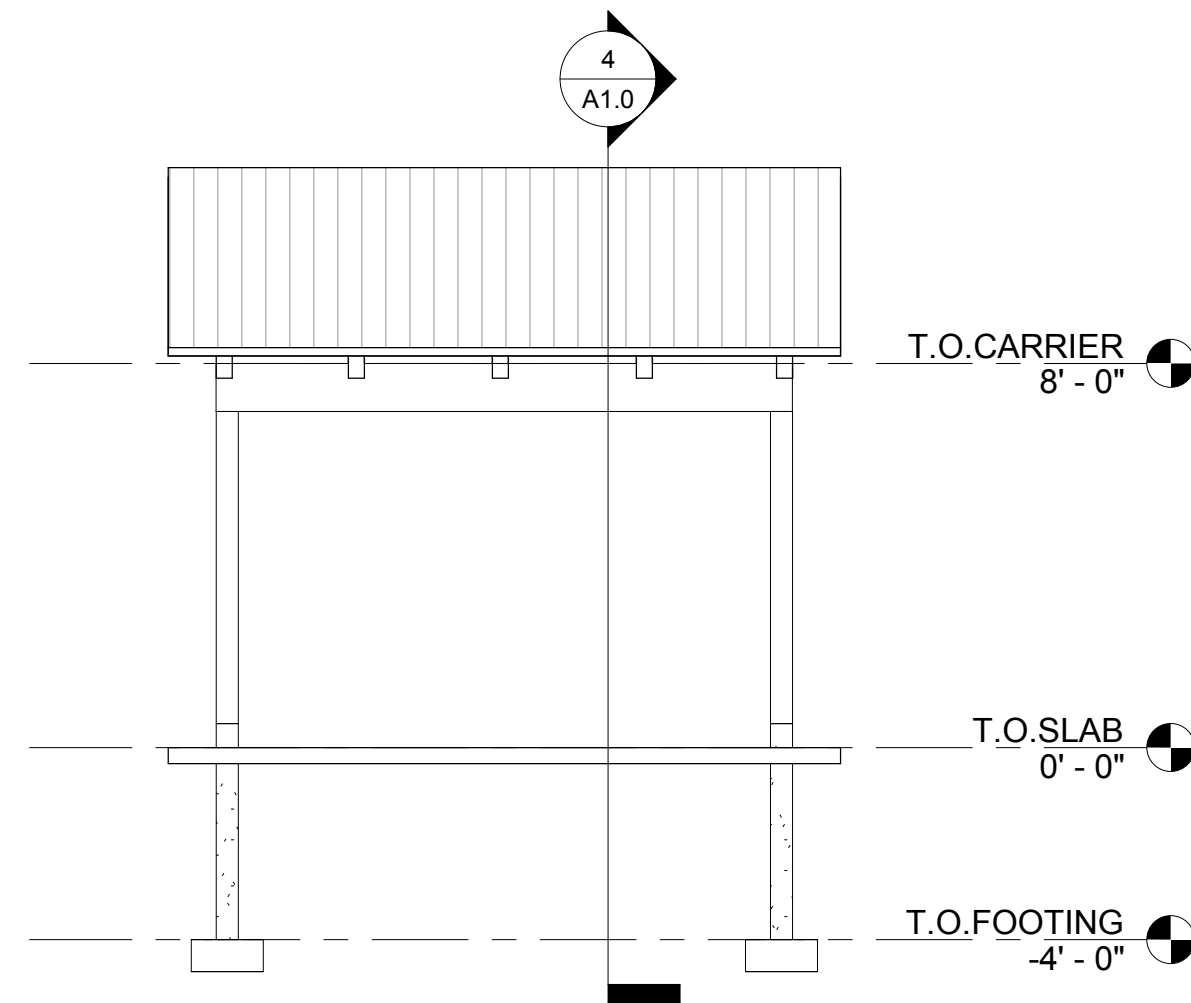
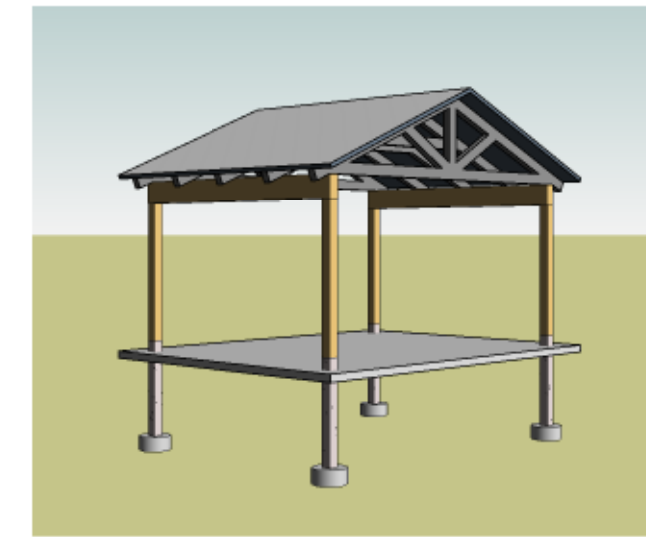

SIDE ELEVATION

1/4" = 1'-0"

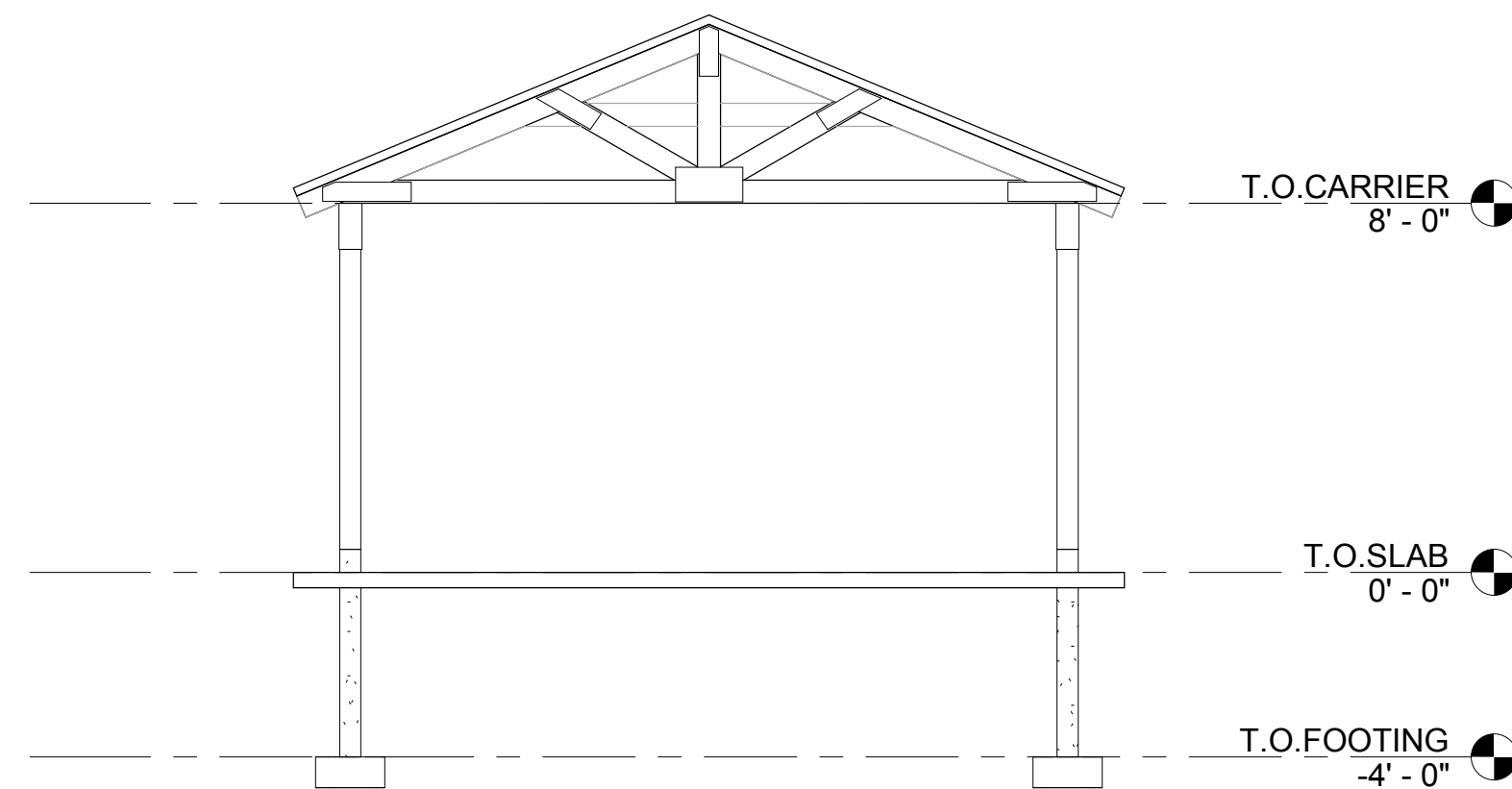

END ELEVATION

1/4" = 1'-0"

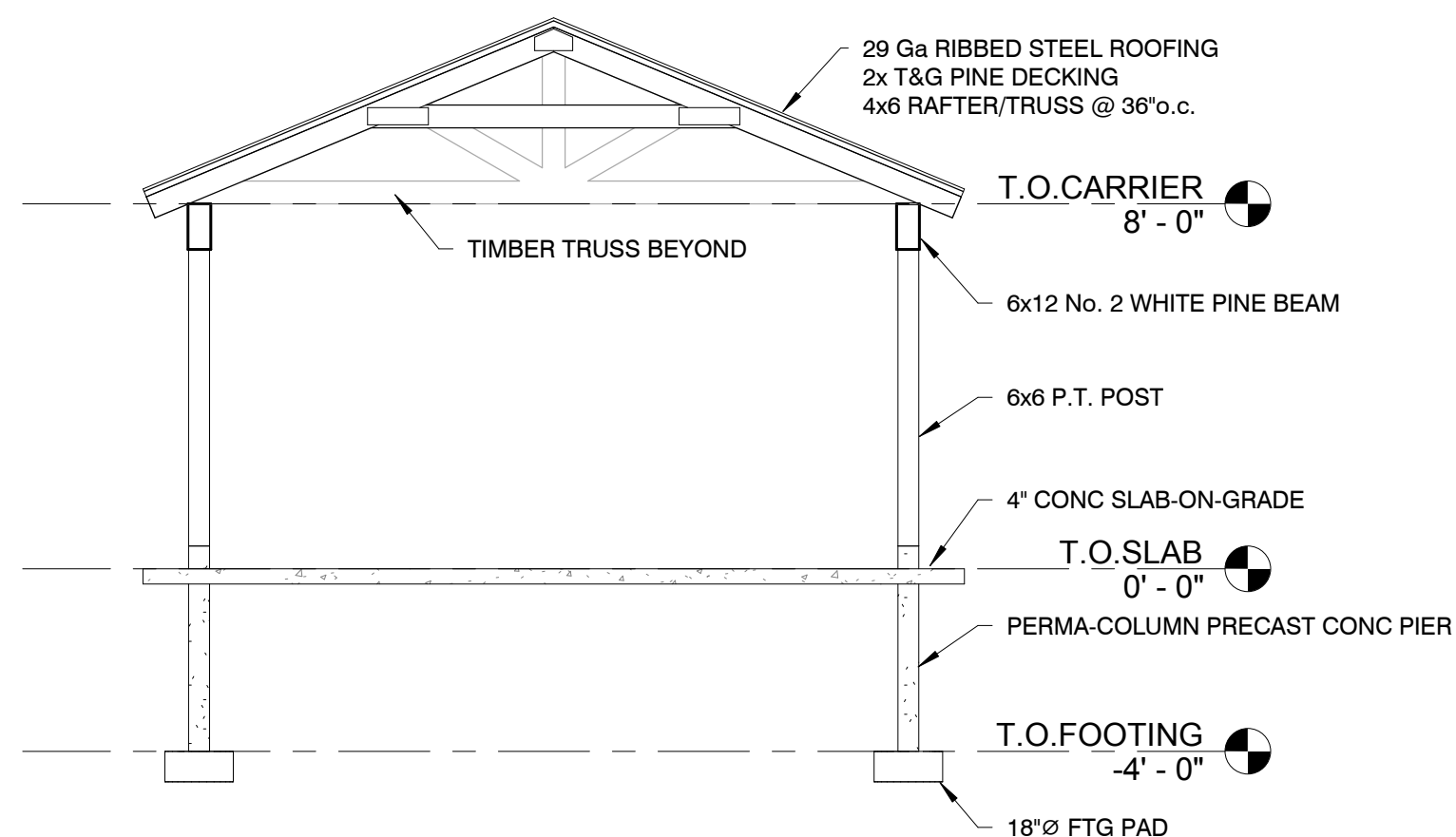

BUILDING SECTION

1/4" = 1'-0"

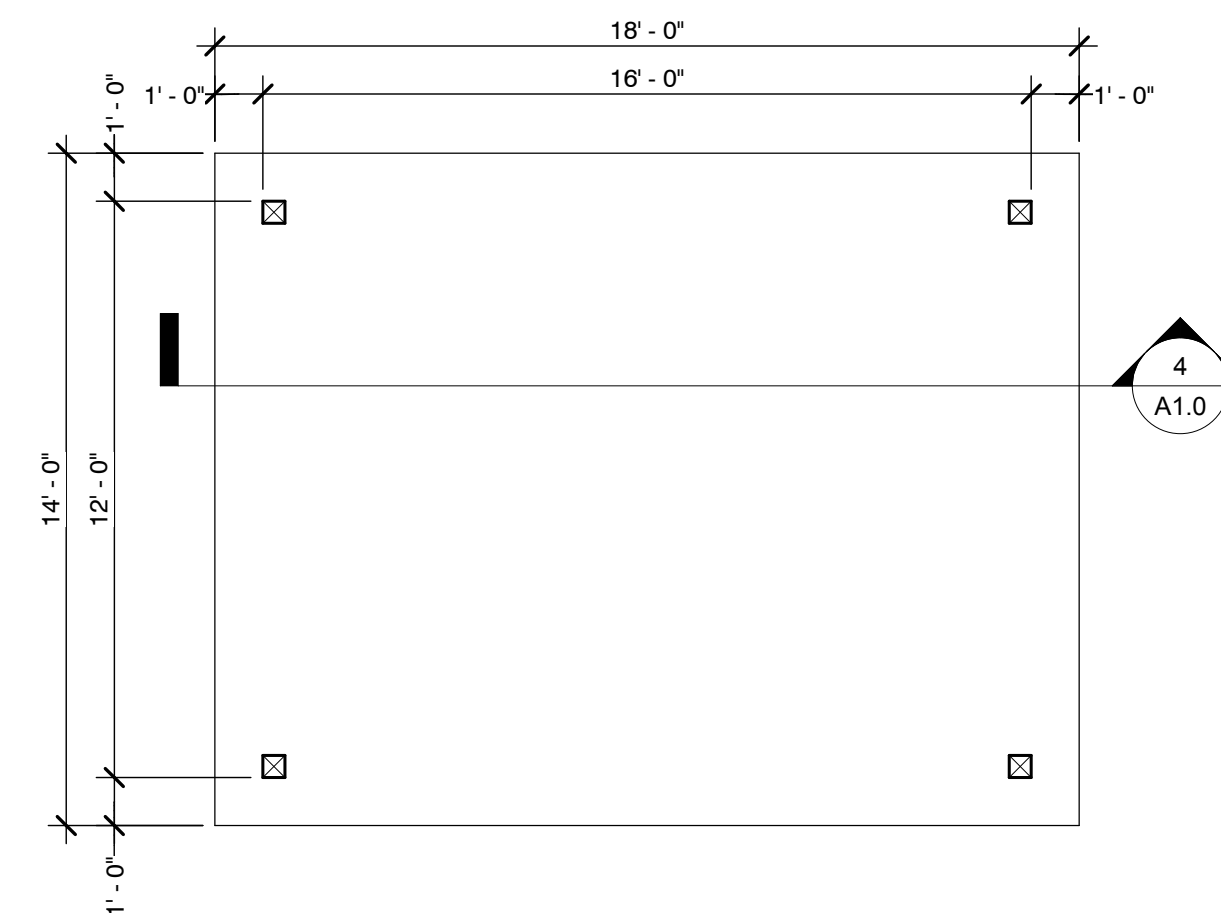

BUILDING PLAN

1/4" = 1'-0"

Plans For:
Norwood Township

Issue/Revise
review 03/19/24

pressell
engineering
&
design
8995 W. Kelly Rd.
Lake City, MI 49651
231.839.3969

Project No.
2414

Sheet No.
A1.0

00640 Lakeside Drive - Clarkston

Approximate
Delivery Date

Spring 2024

VALLEY BACKYARDS
5412 NORWEGIAN RD.
EAST JORDAN, MI 49727
231-536-2693

Customer Order #

Sold by

Leann Miller

Ben Fricke

Name Nowood Township Phone 616-566-4708 Date 9-18-23

Address Nowood Township Park Work # _____

Qty.	Description	Price	Amount
	timber frame pavilion		
	Size 12x16		
	Style: <input checked="" type="checkbox"/> Gable <input type="checkbox"/> Gambrel <input type="checkbox"/> Shed <input type="checkbox"/> Salt Box		
	Woodsiding	Metal Siding	
	Dura Temp	Siding Color	
	Roof Color	Trim Color	
	4' or 6' Porch		
	9x15 Vents		
	Ridgeskylights		
	Entrance ramp		
	Windows		
	Doors: <input type="checkbox"/> 3' Entry <input type="checkbox"/> Roll Up <input type="checkbox"/> Double 5' <input type="checkbox"/> Double 6'		
	White Cedar Railing		
	Loft	Workbench	
	Cathedral Ceiling w/ stained t&g pine		
	OSB Under Siding		
	Shutters		
	Gable Eave ✓		
	Other		
	Loading Instructions		

12x16 pavilion built on-site w/ 4" concrete slab (14x18) smooth finish - includes permit & drawings & site prep, complete package built as public use / commercial

2024 price \$12,975.00

trustees @ nowood township.org

1/3 down -
Balance at completion
Thanks